

# Catálogo Técnico





<b>Detalle</b>	<b>referencia</b>
Listado de perfiles.....	05
Perfiles escala 1:1.....	10
Listado de accesorios.....	21
Ventana y puerta corrediza de 2 hojas corte a 90°.....	24
Ventana y puerta corrediza de 3 hojas corte a 90°.....	34
Ventana y puerta corrediza de 4 hojas corte a 90°.....	40
Ventana y puerta corrediza de 2 hojas corte a 45°.....	42
Ventana de abrir/oscilobatiente 1 y 2 hojas coplanar.....	46
Ventana de abrir/oscilobatiente 1 y 2 hojas escalonada.....	52
Ventana de abrir/oscilobatiente 1 y 2 hojas coplanar con cámara compensadora.....	56
Paño fijo.....	60
Ventana ventiluz.....	62
Ventana banderola.....	65
Ventana desplazable.....	68
Puerta de rebatir 1 hoja.....	71
Puerta de rebatir 2 hojas.....	74
Ventana guillotina.....	78
Perfiles de acople.....	82
Uso de contravidrios.....	84
Recomendaciones para el taqueado de vidrios.....	85
Mecanizados corrediza 90° y 45°.....	86
Mecanizados batientes.....	107
Dimensiones de fabricación.....	114

# Módena2





















Módena 2 es una marca registrada de Aluar Aluminio Argentino SAIC.

Prohibida la modificación, publicación o venta, total o parcial de estos documentos, sin la previa autorización por parte de Aluar División Elaborados. Aluar División Elaborados en ningún caso será responsable por los deficientes trabajos ejecutados por terceros en aberturas armadas con nuestros perfiles. Será de exclusiva responsabilidad del instalador, proyectista y/o contratista la previa y correcta verificación estructural de acuerdo a la zona de colocación, exposición y presión de viento, y verificación del balance térmico teniendo en cuenta el tipo de vidrio a utilizar, la temperatura exterior, interior, la humedad relativa, tipo de calefacción, etc.













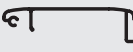





La empresa se reserva el derecho de modificar total o parcialmente las especificaciones contenidas en este catálogo sin previo aviso.

Este catálogo fue actualizado en Octubre de 2024.











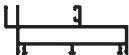

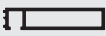



## Módena2 / listado de perfiles

Perfil N°	Forma	Peso kg/m	Descripción
6204		0.721	Zócalo y cabezal hoja vidrio simple vent. y pta. corrediza
6206		0.186	Tapa premarco curvo para clip plástico
6209		1.266	Zócalo alto hoja vidrio simple puerta corrediza
6217		0.294	Contravidrio recto 29 mm
6220		0.176	Contravidrio recto 5 mm
6221		0.767	Travesaño angosto paño fijo
6222		0.842	Travesaño ancho paño fijo
6223		0.918	Encuentro central vent. de abrir de 2 hojas con cámara compensadora
6224		0.794	Encuentro central vent. de abrir de 2 hojas DC/pta. rebatir
6225		0.257	Contravidrio recto 22 mm
6226		0.211	Contravidrio recto 15 mm
6228		0.186	Tope de mosquitero ventana y puerta corrediza
6230		0.213	Contravidrio curvo 29 mm
6231		0.159	Contravidrio curvo 15 mm
6232		0.181	Contravidrio curvo 22 mm
6233		0.135	Contravidrio curvo 8 mm
6234		0.888	Hoja curva ventana de abrir con cámara compensadora
6237		0.176	Contravidrio curvo 12 mm
6238		0.189	Contravidrio recto 8 mm





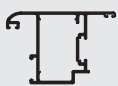









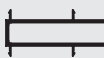
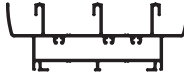

## Módena2 / listado de perfiles

Perfil N°	Forma	Peso kg/m	Descripción
6239		0.748	Travesaño hoja vidrio simple puerta corrediza
6243		0.548	Guía de cortina común
6244		0.913	Guía de cortina barrio
6245		0.629	Tapa cinta
6246		0.292	Encuentro central 4 hojas vent. y pta. corrediza
6249		0.689	Zócalo y cabezal de hoja DVH vent. y pta. corrediza
6252		1.237	Zócalo alto hoja DVH puerta corrediza
6253		0.689	Travesaño hoja DVH puerta corrediza
6254		0.302	Bisagra tapa cinta
6255		0.424	Bastidor mosquitero
6256		0.543	Travesaño mosquitero
6266		0.383	Bastidor vidrio repartido vent. de abrir y paño fijo
6267		0.383	Bastidor vidrio repartido vent. y pta. corrediza
6268		0.429	Travesaño vidrio repartido vent. y pta. corredizar
6293		0.724	Parante central externo ventana guillotina
6294		0.724	Parante central interno ventana guillotina
6295		0.783	Zócalo y cabezal de hoja ventana guillotina
6296		1.636	Jamba de marco ventana guillotina
6297		1.002	Umbral de marco ventana guillotina



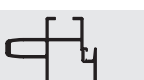



## Módena2 / listado de perfiles

Perfil N°	Forma	Peso kg/m	Descripción
6298		1.077	Dintel de marco ventana guillotina
6299		0.119	Tapa de resortes ventana guillotina
6900		0.551	Parante lateral de hoja ventana guillotina
6901		0.710	Premarco ventana guillotina/3 guías
6903		0.462	Acople marco guillotina
6907		0.338	Suplemento parante central corrediza corte a 45°
6908		0.894	Hoja corrediza corte a 45° p/vidrio simple
6909		0.840	Hoja corrediza corte a 45° DVH
6910		1.183	Parante central reforzado corrediza corte a 45°
6911		1.126	Parante central ref. DVH corrediza corte a 45°
7705		0.821	Marco curvo para PF-VA-VB-VV-PR
7706		0.909	Hoja curva ventana de abrir DC y ventana banderola
7707		0.772	Marco coplanar vent. abrir DC, vent. banderola, pta. de rebatir y vent. ventiluz
7708		0.902	Hoja curva ventiluz
7709		0.724	Marco ventana desplazable
7710		1.083	Hoja ventana desplazable curva
7711		0.243	Tapa premarco Módena
7712		0.284	Perfil de acople

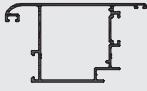
## Módena2 / listado de perfiles

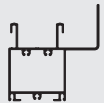
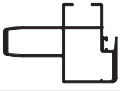
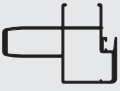
Perfil N°	Forma	Peso kg/m	Descripción
7713		1.310	Umbral y dintel de ventana y puerta corrediza
7714		0.724	Jamba de marco de ventana y puerta corrediza
7715		0.678	Parante lateral hoja vidrio simple vent. y pta. corrediza
7716		0.710	Parante central hoja vidrio simple vent. y pta. corrediza
7717		0.834	Marco coplanar vent. de abrir con cámara compensadora
7718		0.774	Perfil de acople a 90°
7719		0.632	Suplemento parante central corrediza corte a 45°
7720		1.277	Columna de acople reforzada
7721		1.866	Umbral y dintel de marco de 3 guías vent. y pta. corrediza
7722		1.112	Jamba de marco de 3 guías vent. y pta. corrediza
7723		0.643	Parante lateral de hoja DVH vent. y pta. corrediza
7724		0.675	Parante central hoja DVH vent. y pta. corrediza
7725		0.964	Parante central con tirador hoja DVH pta. corrediza
7726		1.193	Jamba y cabezal de hoja puerta de rebatir
7727		0.448	Premarco Módena
7728		0.999	Parante central con tirador hoja vidrio simple pta. corrediza
7729		1.261	Travesaño hoja pta. de rebatir
7730		1.688	Zócalo hoja puerta de rebatir
7731		1.210	Marco corrediza corte a 45°

## Módena2 / listado de perfiles

Perfil N°	Forma	Peso kg/m	Descripción
7732		0.316	Tapajunta ancho Módena
7877		1.185	Jamba y cabezal de hoja puerta de rebatir hacia afuera
7878		0.896	Marco puerta de rebatir coplanar para bisagra de aplica
7879		1.550	Umbral corrediza con caja de agua reforzada
7880		1.223	Parante central reforzado para pta. corrediza vidrio simple
7918		1.195	Parante central reforzado para pta. corrediza DVH
8062		0.167	Tapa premarco recto para fijar con clip plástico
8063		0.230	Tapa premarco recto para fijar con tornillo
8245		0.374	Adaptador DVH corrediza 90°
8376		0.381	Premarco liviano Módena

## Módena2 / perfiles

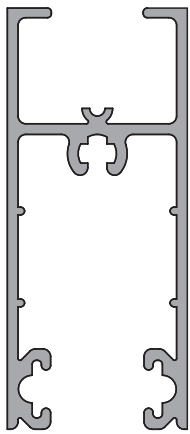

**6204**  
0.721 kg/m

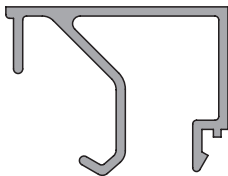

**6217**  
0.294 kg/m

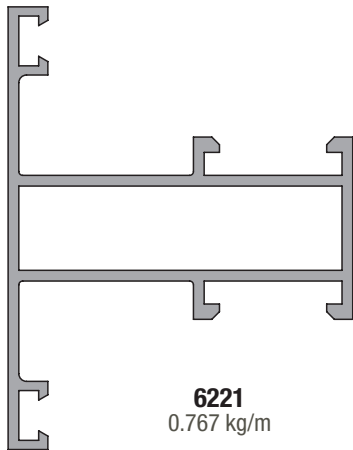

**6221**  
0.767 kg/m

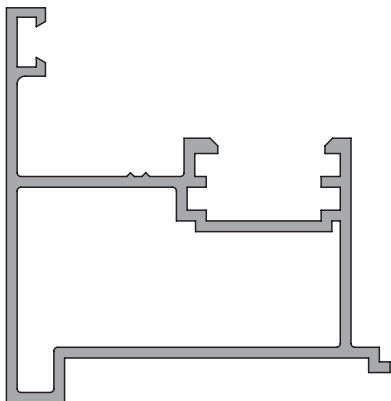

**6224**  
0.794 kg/m



**6209**  
1.266 kg/m

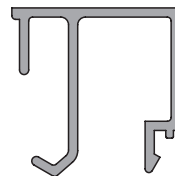

**6225**  
0.257 kg/m

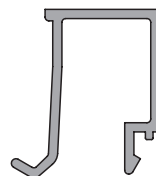

**6226**  
0.211 kg/m

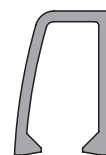

**6228**  
0.186 kg/m

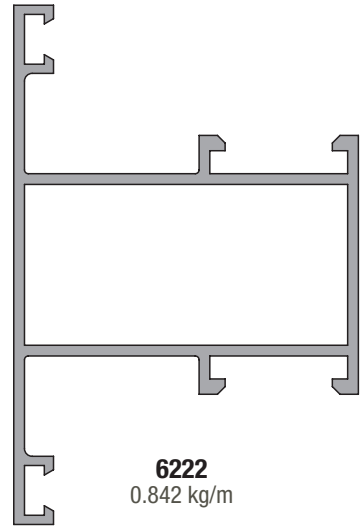

**6222**  
0.842 kg/m

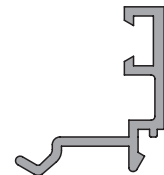

**6220**  
0.176 kg/m

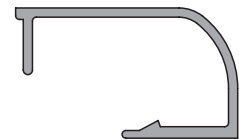

**6230**  
0.213 kg/m



**6231**  
0.159 kg/m

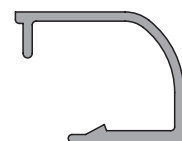

**6232**  
0.181 kg/m

## Módena2 / perfiles



**6233**  
0.135 kg/m



**6237**  
0.176 kg/m

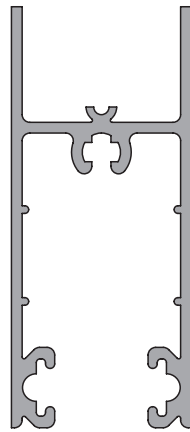

**6249**  
0.689 kg/m

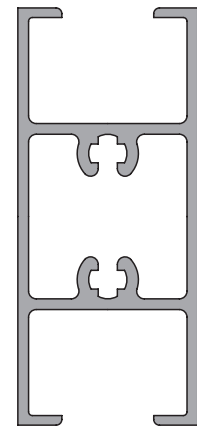

**6239**  
0.748 kg/m

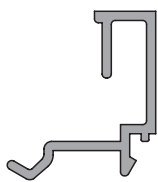

**6238**  
0.189 kg/m

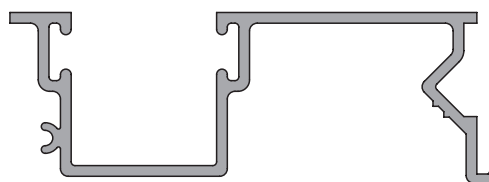

**6243**  
0.548 kg/m

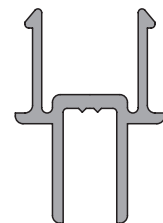

**6246**  
0.292 kg/m

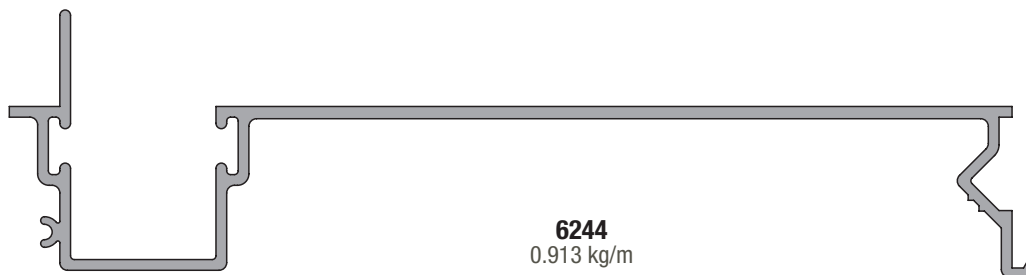

**6244**  
0.913 kg/m

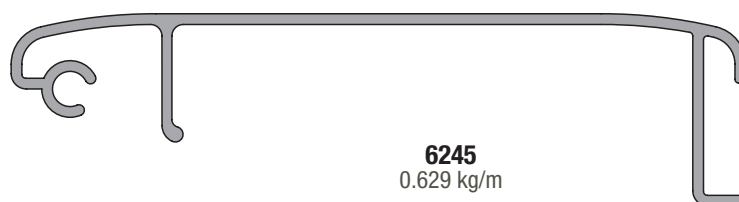

**6245**  
0.629 kg/m

## Módena2 / perfiles

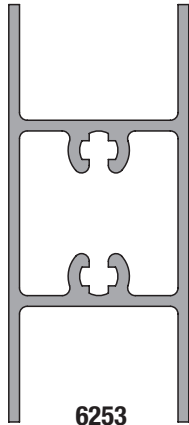

**6253**  
0.689 kg/m

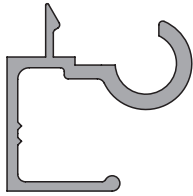

**6254**  
0.302 kg/m

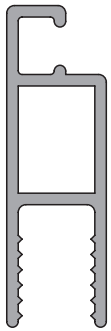

**6255**  
0.424 kg/m

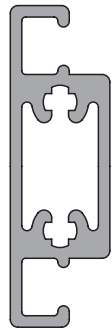

**6256**  
0.543 kg/m



**6252**  
1.229 kg/m

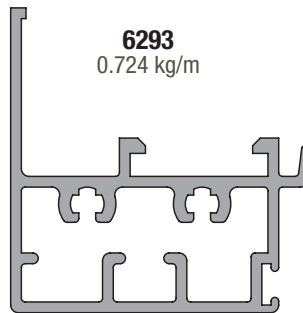

**6293**  
0.724 kg/m

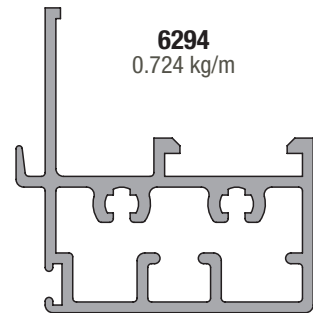

**6294**  
0.724 kg/m

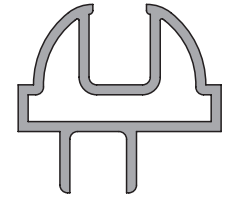

**6266**  
0.383 kg/m

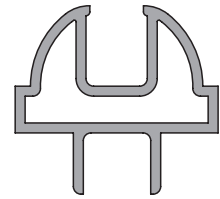

**6267**  
0.383 kg/m

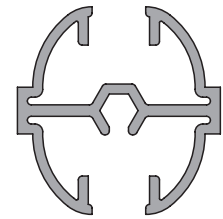

**6268**  
0.429 kg/m

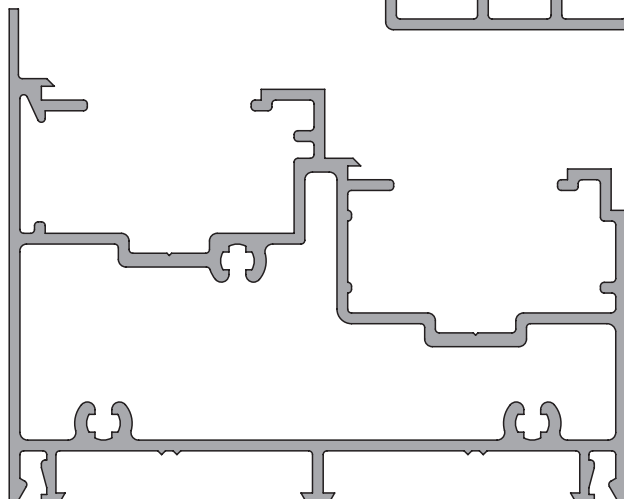

**6296**  
1.636 kg/m

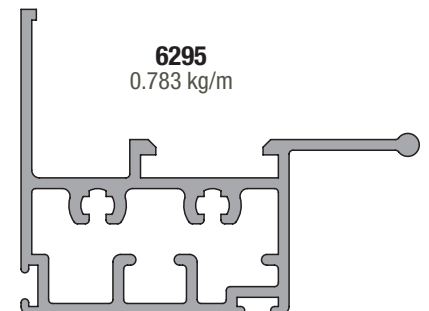

**6295**  
0.783 kg/m

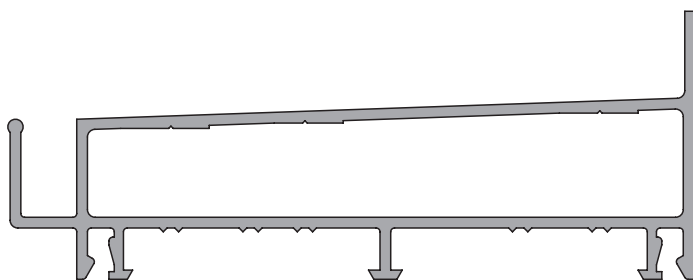

**6297**  
1.002 kg/m

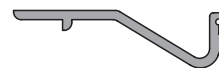

**6299**  
0.119 kg/m

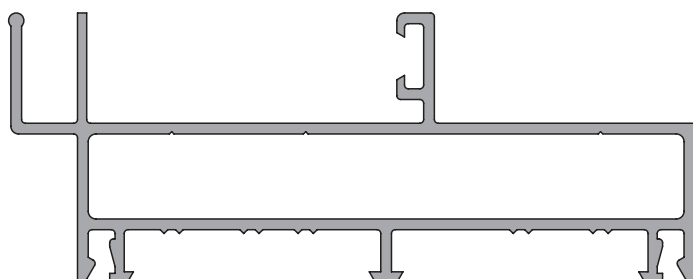

**6298**  
1.077 kg/m

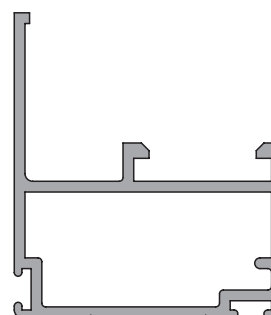

**6900**  
0.551 kg/m

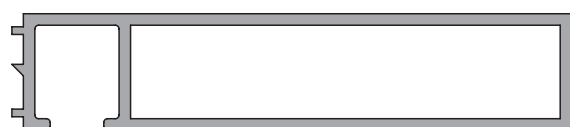

**6901**  
0.710 kg/m

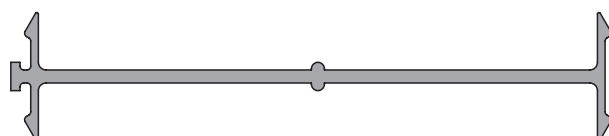

**6903**  
0.462 kg/m

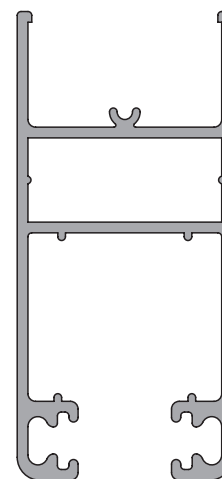

**6909**  
0.840 kg/m

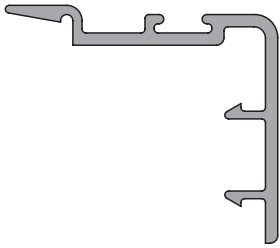

**6907**  
0.338 kg/m

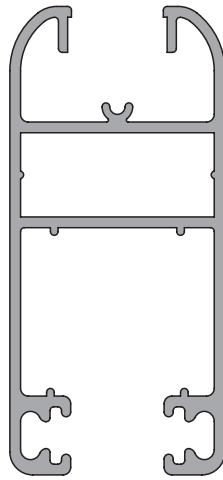

**6908**  
0.894 kg/m

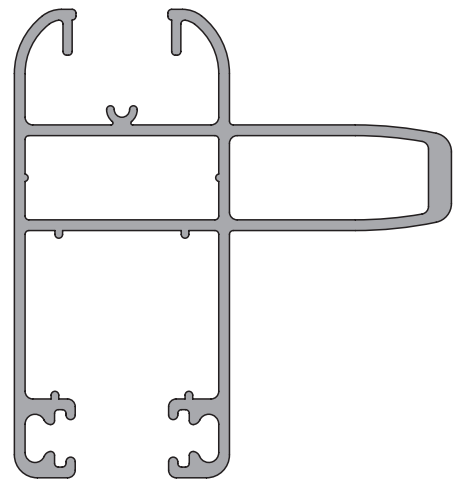

**6910**  
1.183 kg/m

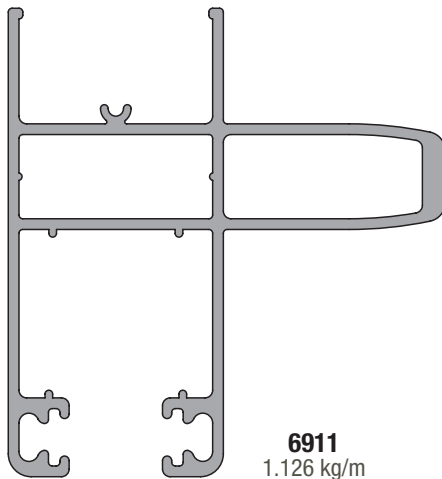

**6911**  
1.126 kg/m

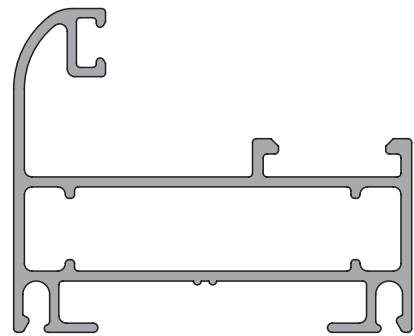

**7705**  
0.821 kg/m

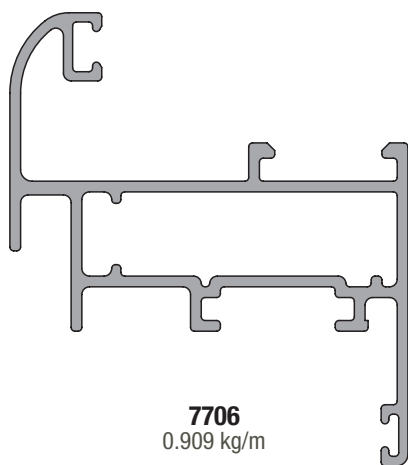

**7706**  
0.909 kg/m

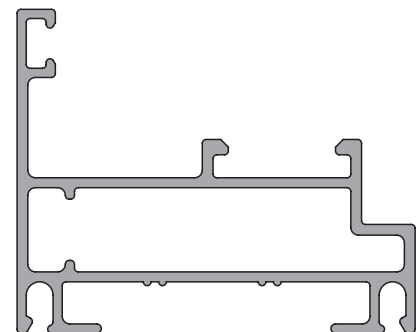

**7707**  
0.772 kg/m

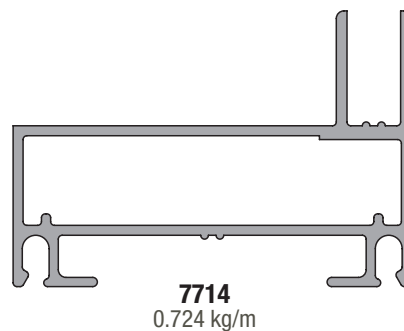
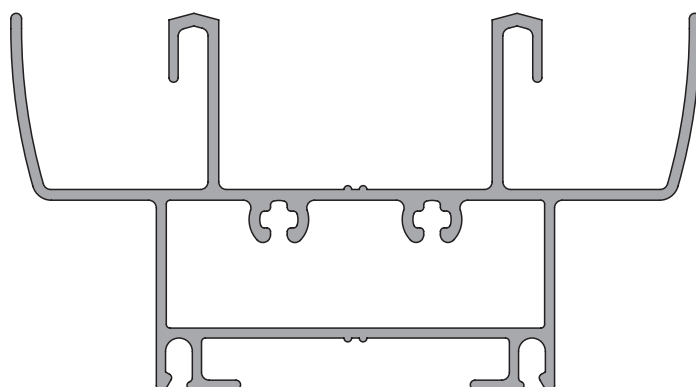
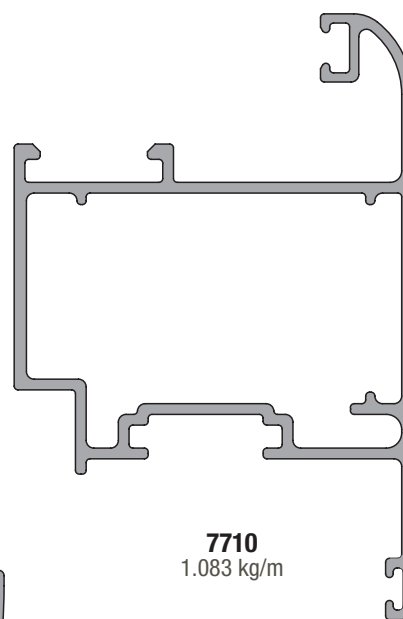
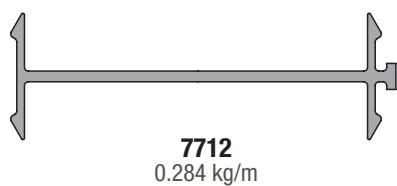
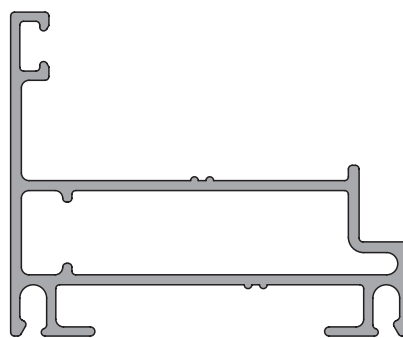
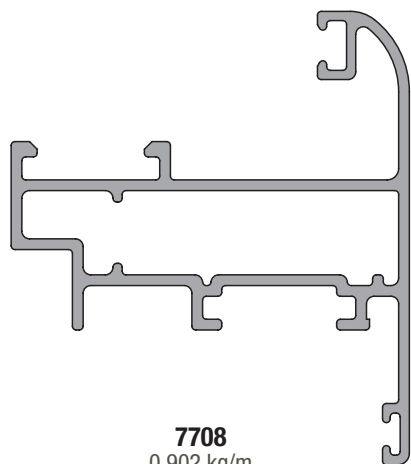

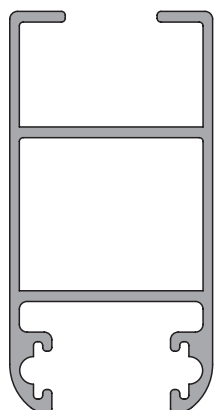

**7715**  
0.678 kg/m

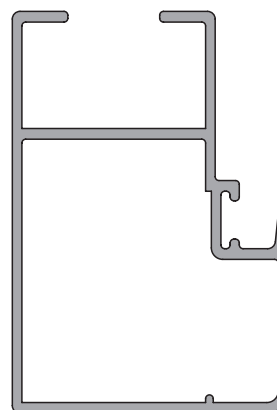

**7716**  
0.710 kg/m

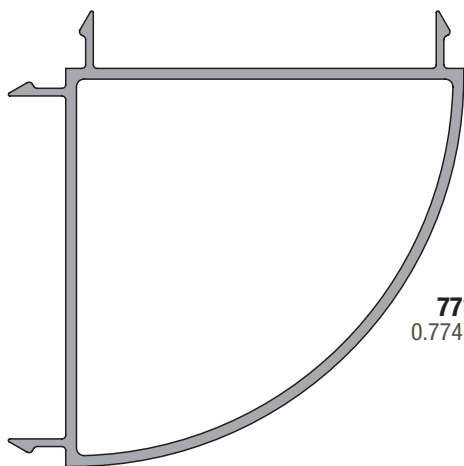

**7718**  
0.774 kg/m

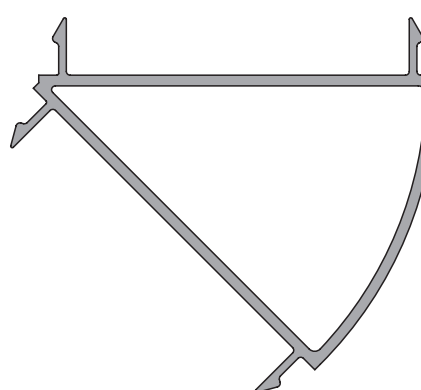

**7719**  
0.632 kg/m

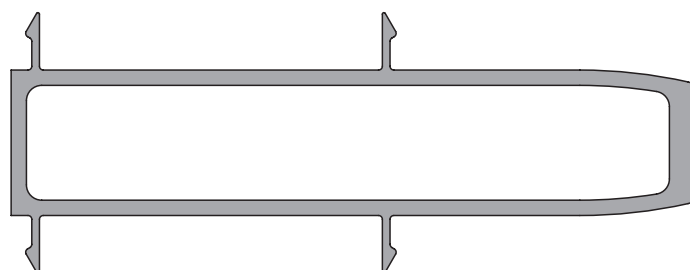

**7720**  
1.277 kg/m

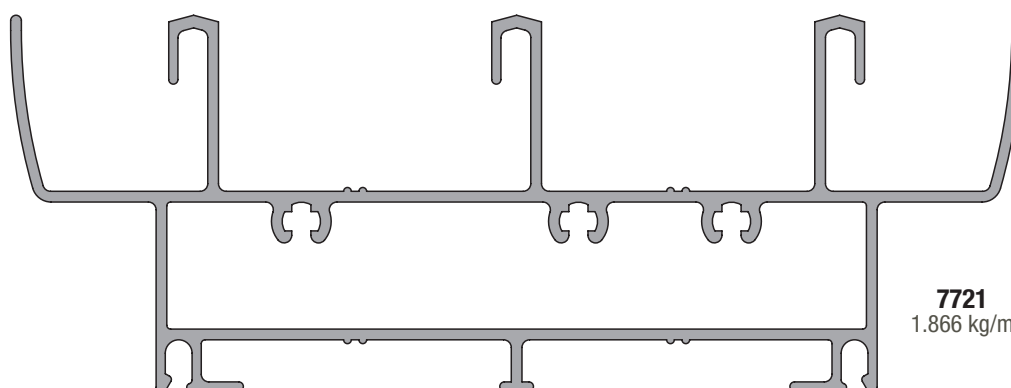

**7721**  
1.866 kg/m

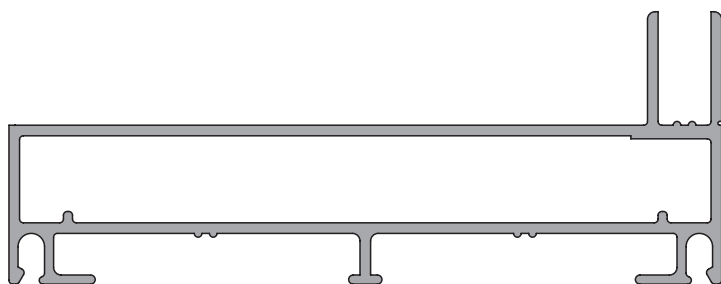

**7722**  
1.112 kg/m

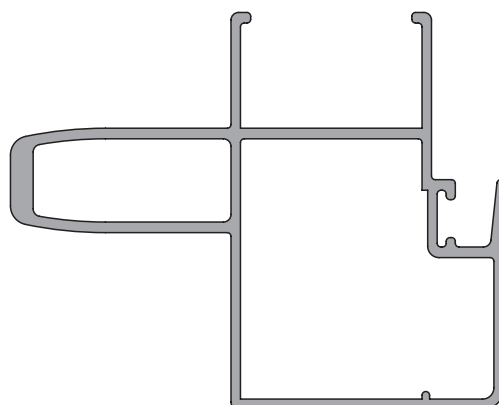

**7725**  
0.964 kg/m

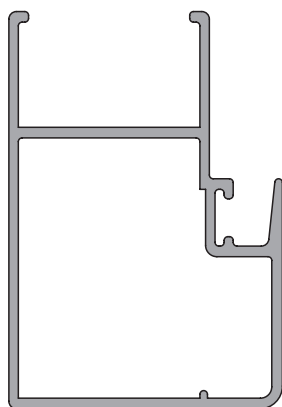

**7724**  
0.675 kg/m



**7723**  
0.643 kg/m

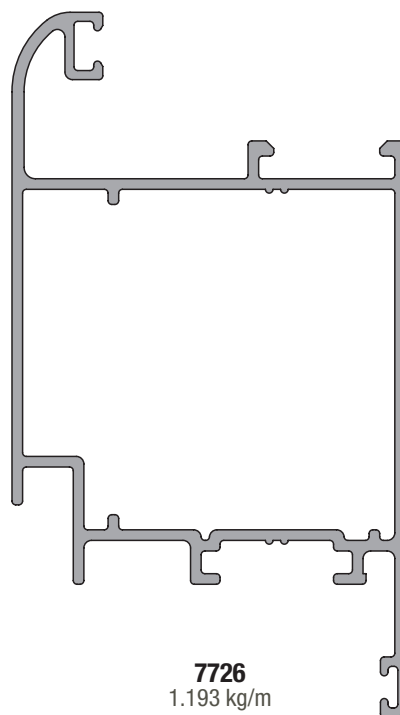

**7726**  
1.193 kg/m

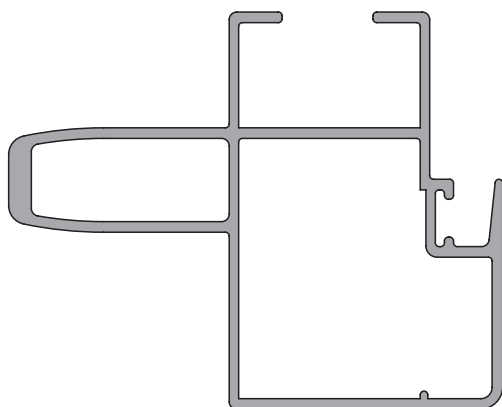

**7728**  
0.999 kg/m

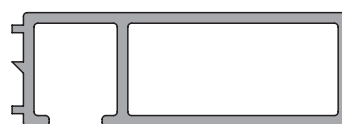

**7727**  
0.448 kg/m

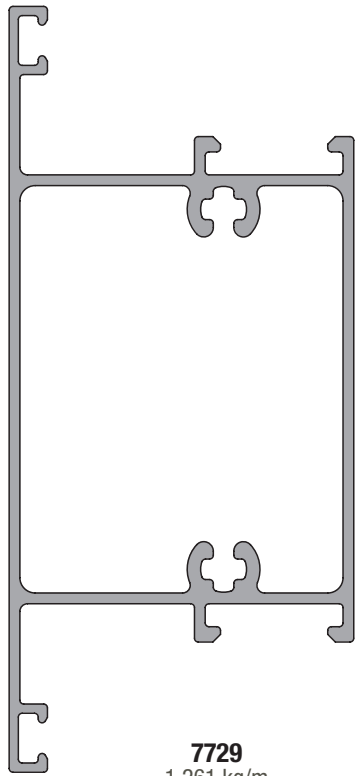

**7729**  
1.261 kg/m



**7730**  
1.688 kg/m

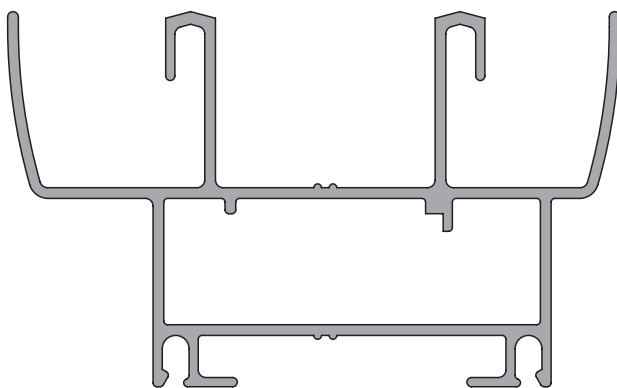

**7731**  
1.210 kg/m

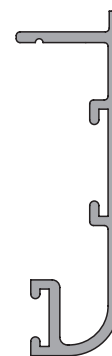

**7732**  
0.316 kg/m

## Módena2 / perfiles

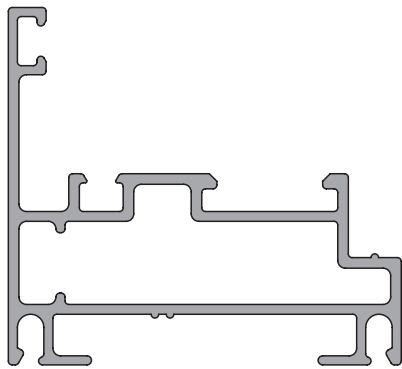

**7717**  
0.834 kg/m

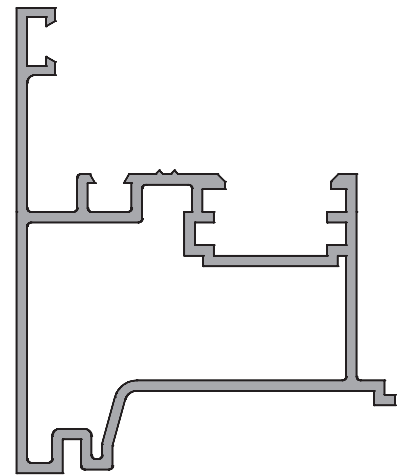

**6223**  
0.918 kg/m

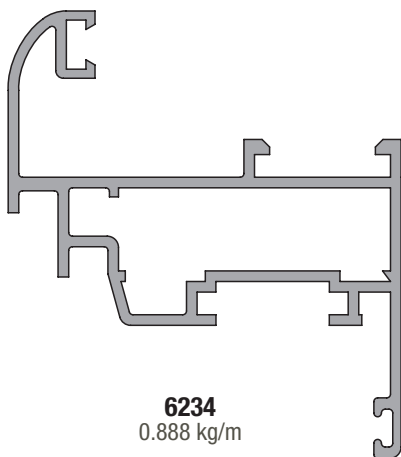

**6234**  
0.888 kg/m

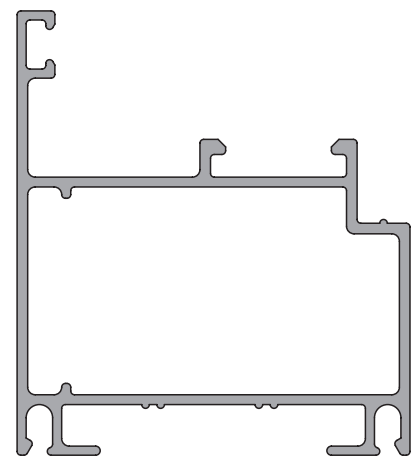

**7878**  
0.896 kg/m

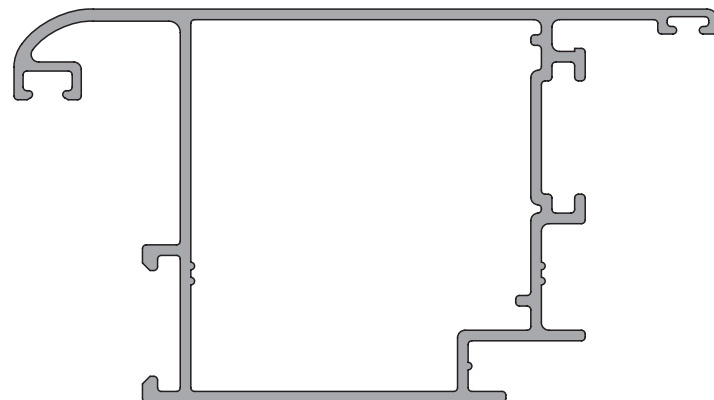

**7877**  
1.185 kg/m

## Módena2 / perfiles

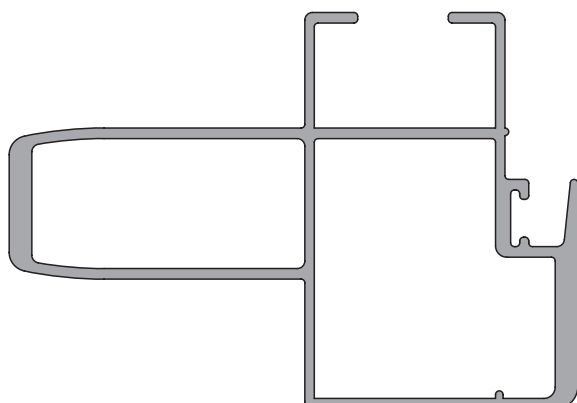

**7880**  
1.223 kg/m



**6206**  
0.186 kg/m

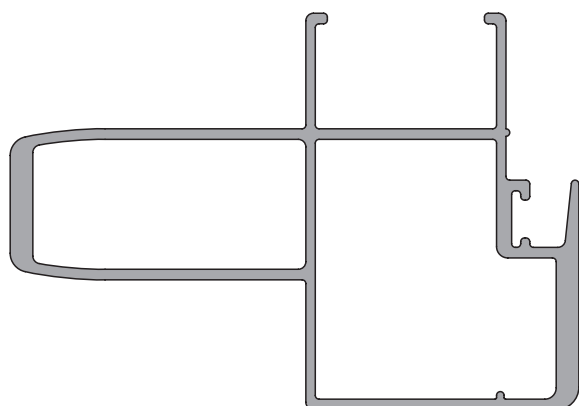

**7918**  
1.195 kg/m



**8062**  
0.167 kg/m



**8063**  
0.230 kg/m

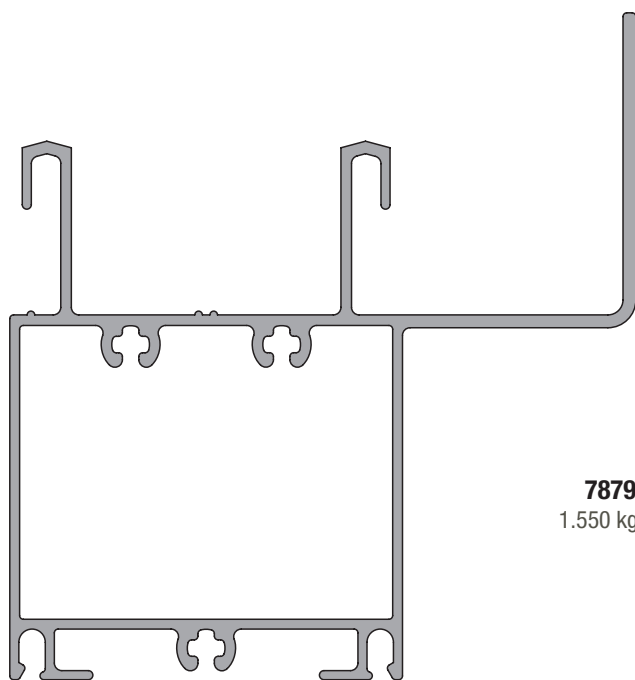

**7879**  
1.550 kg/m

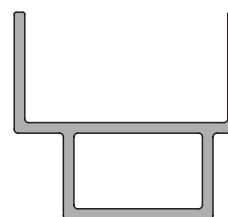

**P-8245**  
0.374 Kg/m<sup>2</sup>

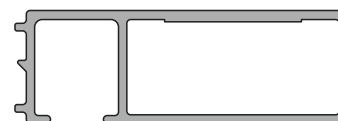

**P-8376**  
0.381 Kg/m

Código	Descripción
B09	Burlete tela mosquitero
B29	Burlete cuña espesor 2 mm
B30	Burlete cuña espesor 3 mm
B31	Burlete cuña espesor 4 mm
B57	Burlete tapa premarco
B60	Burlete "U" para vidrio corrediza
B66	Burlete junta central cámara compensadora ventana de abrir
B67	Burlete exterior doble contacto
B68	Burlete exterior para vidrio (batientes)
B69	Burlete hermeticidad marco-premarco
B70	Burlete cierre mosquitero
B73	Burlete cierre tablillas postigón regulable
B76	Burlete cierre inferior ventana guillotina
B79	Burlete interior doble contacto
B80	Burlete exterior doble contacto
BPV	Burlete cierre superior ventana guillotina
C3	Felpa de polipropileno base 7x7 mm con fin-seal
C4	Felpa de polipropileno base 5x7 mm con fin-seal
C8	Felpa de polipropileno base 5x4 mm con fin-seal
C14	Felpa de polipropileno base 7x6 mm con fin-seal
C15	Felpa de polipropileno base 7x8 mm con fin-seal
E62	Escuadra de alineamiento para tapa premarco 7149 (marcos 75 mm)
E66	Escuadra de alineamiento tapa premarco
E69	Escuadra de armado hojas y marcos vent.de abrir-banderola-ventiluz-desplazable Monticelli art. 0445B (pulsante 8 mm)
E70	Escuadra de armado hojas puerta de rebatir-desplazable Monticelli art. 0429 (pulsante 8 mm)
E71	Soporte travesaño paño fijo 6221
E72	Soporte travesaño paño fijo 6222
E73	Escuadra de armado mosquitero
E77	Escuadra de armado premarco 80 mm
E81	Escuadra de armado hoja ventana guillotina
E83	Escuadra de armado marco corrediza Monticelli art. 0421 (pulsante 8 mm)
E97	Escuadra de armado hojas corredizas Monticelli art. 0404 (pulsante 10 mm)
E98	Escuadra de alineamiento hojas corredizas a 45°
E100	Escuadra suplementaria puerta de rebatir
E106	Escuadra de armado premarco
H14	Cierre banderola
H36/A	Bisagra a fricción Securistyle "Senator" 250 o Cotswold HD10
H36/B	Bisagra a fricción Securistyle "Senator" 400 o Cotswold HD16
H36/C	Bisagra a fricción Securistyle "Senator" 550 o Cotswold HD22
H36/D	Bisagra a fricción Securistyle "President" 730A o Cotswold "Validus"
H36/E	Limitador de apertura para ventana desplazable, Securistyle o Cotswold
H42	Pasador puerta de rebatir de 2 hojas Tanit art. 4198, Giesse "Supergiap" art. 02153 o Mon-Pat art. 040506NN3
H43	Traba varillas para terminal o pasador Tanit art. 4079, Giesse art. 01322 o Mon-Pat art. 060168NN4
H44	Soporte hoja ventana de abrir Tanit art. 4080, Giesse art. 02390 o Mon-Pat art. 060469NN3
H45	Mecanismo básico para oscilobatiente Tanit "Ribanta 4" art. 4141, Giesse "Futura" art. 04704+04711 o Mon-Pat art. 100100NE4
H45/F	Falleba para ventana oscilobatiente Tanit "Manon" art. 4009, Giesse "Prima" art. 01033 o Mon-Pat "Pronto Max" art. 040204NE4

## Módena2 / listado de accesorios

Código	Descripción
H45/F	Falleba para ventana oscilobatiente Tanit "Florencia" art. 4011 o Giesse "Euro" art. 01090
H47	Falleba ventana de abrir con bloques de conexión Tanit "Florencia" art. 4661, Giesse "Prima" art. 01024+00826 o Mon-Pat "Pronto Max" art. 040205NE4
H48	Falleba ventana de abrir con bloques de conexión Tanit "Manon" art. 4022 o Giesse "Euro" art. 01000+00826
H49	Pasador ventana de abrir de 2 hojas Tanit art. 4062, Giesse "Giap" art. 02111 o Mon-Pat "Ciao" art. 040502NN4
H50	Manija doble balancín para puerta de rebatir Tanit "Florencia" art. 4241, Giesse "Supermaster" art. 02462 o Mon-Pat "Sicurezza" art. 040302NE4
H51	Cerradura puerta de rebatir Kallay 2006M
H51/M	Cerradura multipunto para puerta de rebatir Tanit "H51 Multipunto", Giesse art.04646+kit o Mon-Pat "H51Plus"
H52	Cierre banderola Tanit "Sorrento" art. 5145, Giesse "Twin" art. 01704 o Mon-Pat "Certo" art. 040106NE4
H53	Brazo sostén banderola Tanit art. 3797, Giesse "Rallenty" art. 02040 o 02041 o Mon-Pat "Rality" art. 070201AI4
H56	Cierre lateral con kit de enganche para corredizas hojas a 90° Tanit "Milano" art. 5075, Giesse "Brio" art. 02992+00802 o Mon-Pat "Imperio" art. 030109NE4
H61	Bisagra de 2 alas Tanit "Roma" art. 5143, Giesse "Flash" art. 00120 o Mon-Pat "Plus" art. 050140NE4
H62	Bisagra de 3 alas Tanit "Roma" art. 5141, Giesse "Bridge" art. 00600 o Mon-Pat "Plus" art. 050142NE4
H63	Brazo de empuje ventiluz Tanit art. 4158 o 4159, Giesse "Ombu" art. 00889 o 00890 o Mon-Pat "Supremo" art. 070307NE4 o 070309NE4
H67	Falleba para postigón de rebatir Giesse "Coupe" o Tanit "Fuori Bassa"
H68	Kit de movimiento para falleba H67 postigón de rebatir
H79	Terminal de varillas Tanit art. 4028, Giesse art. 02114 o Mon-Pat art. 060171NN4
H80	Trabas para tercer cierre de fallebas
H81/H105	Bisagra de 2 piezas para hoja coplanar y tercer hoja Tanit "Roma" art.5105, Giesse "Flash" o Mon-Pat art. 050128NE4
H82/H106	Bisagra de 3 piezas para hoja coplanar y tercer hoja Tanit "Roma" art. 5107, Giesse "Bridge" o Mon-Pat art. 050130NE3
H83	Pasador para segunda hoja ventana oscilobatiente Tanit art. 5650, Giesse art. 04274 o Mon-Pat art. 040506NN3
H86	Conjunto cierre multipunto, falleba, caja y pernos para ventana desplazable
H87	Limitador de apertura para banderola Tanit "Piovra" art. 4075 o Giesse "Friz" art. 02030
H89	Tirador para hojas corredizas
H90	Cierre banderola Tanit art. 199 o Mon-Pat art. 040101NE4
H91	Aldaba para ventana desplazable Tanit "Monaco" art. 502, Giesse "Bravo 1" art. 01642 o Mon-Pat "Minerva" art. 040407NE1
H92	Aldaba para ventana desplazable Tanit "Florencia" art. 512, Giesse "Bravo 2" art. 01652 o Mon-Pat "Pronto" art. 040401NE4
H93	Manija doble balancín para puerta de rebatir Tanit "Manon" art.4117, Giesse "Prima" art. 02472 o Mon-Pat "Pronto" art. 040306NE4
H103	Bisagra de aplicar de 2 piezas para hoja coplanar-Tanit "Mecanica" art. 7561, Giesse "Domina 2 alas" o Mon-Pat "Domus" art. 050201NE4
H104	Bisagra de aplicar de 3 piezas para hoja coplanar Tanit "Mecánica" art. 7563, Giesse "Domina 3 alas"
H107	Mecanismo básico para oscilobatiente hojas coplanares Tanit "Ribanta 4", Giesse "Futura" o Mon-Pat
H116	Barra pivot ventana guillotina
H117	Patín lateral ventana guillotina
H118	Resortes compensadores diámetro 5/8" para ventana guillotina
H119	Trabas laterales de hoja ventana guillotina
H120	Cierre central ventana guillotina
H123	Cierre lateral con kit de enganche para hojas a 45° Tanit "Milano" art. 5099, Giesse "Brio" art. 02992+00789 o Mon-Pat "Victoria" art. 030129NE1
H129	Mecanismo cierre bipunto con falleba para corrediza a 90° Tanit "MEC-075" o Giesse "Top Security"
H130	Mecanismo cierre bipunto con falleba para corrediza a 45° Tanit "MEC-081"

Código	Descripción
R39	Rueda fija simple Tanit "Ibiza" art. 5039 o Mon-Pat "Rapid" art. 010301ZN1
R40	Rueda regulable simple Tanit "Ibiza" art. 5116, Giesse "Carrera 1" art. 00806 o Mon-Pat "Roller" art. 010302ZN1
R41	Rueda fija doble Tanit "Ibiza" art. 5040
R42	Rueda regulable doble Tanit "Ibiza" art. 5079, Giesse "Carrera 2" art. 00801 o Mon-Pat "Roller" art. 010303ZN1
R43	Patín deslizador mosquitero
R48	Rueda simple regulable Tanit "Ibiza" art. 5118, Giesse "Carrera 1" art. 03119X o Mon-Pat "Roller" art. 010311ZN1
R49	Rueda doble regulable Tanit "Ibiza" art. 5114, Giesse "Carrera 2" art. 03120 o Mon-Pat "Roller" art. 010312ZN1
S9	Grampa de amure
T1	Tornillo Parker cabeza fijadora N°10 x 1 1/2"
T15/F	Tornillo Parker cabeza fresada N°8 x 1 1/2"
T20	Tornillo Parker cabeza fijadora N°12 x 1 1/2"
T21	Tornillo botón para fijación tope de mosquitero
T88	Taco regulador para fijación de marco Tanit art. 5059, Giesse art. 06500 o Mon-Pat art. 0601036NN1
T89	Tope guía parante lateral
T90	Tope guía parante central
T91	Tapón guías laterales umbral y dintel corrediza
T95	Tapa tornillo diámetro 11 mm (para T1)
T96	Clip para contravidrios curvos Tanit art. 5007, Giesse art. 00864 o Mon-Pat art. 060150NN1
T97	Tapón encuentro central VA de 2 hojas cámara compensadora
T98	Tapón encuentro central VA/PR 2 hojas doble contacto
T99	Porta felpa jambas puerta de rebatir
T100	Tapa tornillo diámetro 13 mm (para T20)
T126	Tapón cruce central de hojas para corrediza corte 45°
T127	Conjunto tope lateral de hojas a 45° Tanit art. 5092, Giesse art. 03199X o Mon-Pat art. 060503ZN1
T128	Tapón parante reforzado corrediza 45°
T130	Boca desagüe caja de agua
T131	Tapa desagote
T139	Tapón plano guías laterales umbral alto corrediza (Perfil 7879)
T140	Tapón plano guías laterales umbral y dintel corrediza
T143	Junta de estanqueidad marco corrediza 2 guías
T144	Tapón cruce central de hojas para corrediza corte 90° 2 guías
T145	Tapón cruce central de hojas para corrediza corte 90° 3 guías
T146	Junta de estanqueidad marco corrediza 3 guías
T147	Tapón de hermeticidad caja de agua corrediza corte 45°
T148	Junta de estanqueidad umbral alto corrediza (Perfil 7879)
T155	Clip para tapa premarcos 6206 y 8062
TP-076	Clip para tapa premarco (TANIT)

Los burletes a utilizar en la colocación de los vidrios se deben verificar de acuerdo al espesor y tipo de vidrio. De acuerdo a la zona de exposición se debe considerar el sellado exterior de los mismos. Las medidas de las felpas a utilizar se deben verificar de acuerdo a la exposición y presión de viento de la zona de colocación. Para la aplicación de contravidrios curvos con el accesorio T96, se recomienda su colocación cada 150 mm. Fijación de marco y premarco: mínimo 2 fijaciones por lado que deben estar como máximo 500 mm entre sí y a no más de 250 mm de las esquinas. Para marcos menores a 500 mm de lado es aceptable colocar solo una fijación por lado.

# Módena2 / ventana corrediza corte a 90° de 2 hojas

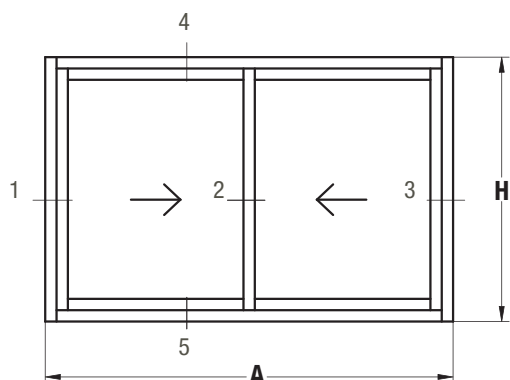

SECCION 4-5

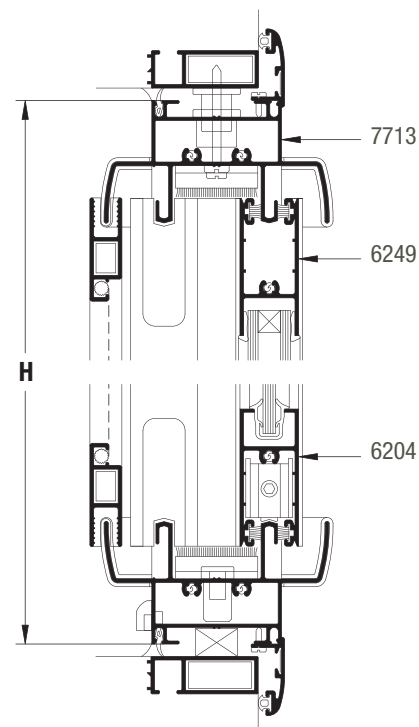

SECCION 1-2-3

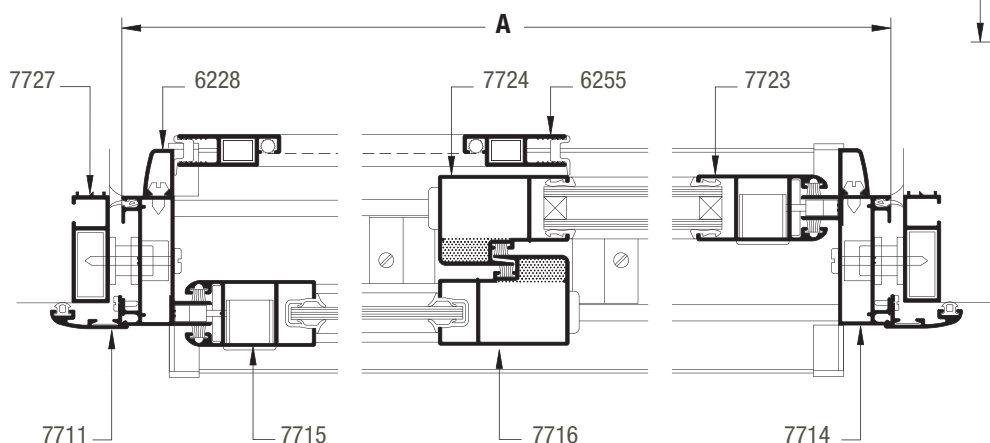

## Dimensión de corte de perfiles

A ancho total del marco H altura total del marco

cantidad de piezas VC2	perfil VS	DVH	descripción	medida mm	corte
2	7727		Jambas premarco	H+40	45-45
2	7727		Umbral y dintel premarco	A+40	45-45
2	7711		Jambas tapa premarco	H+58	45-45
2	7711		Umbral y dintel tapa premarco	A+58	45-45
2	7714		Jamba de marco	H	90-90
2	7713		Umbral y dintel de marco	A-42	90-90
2	7715	7723	Parante lateral de hoja	H-79	90-90
2	7716	7724	Parante central de hoja	H-79	90-90
4	6204	6249	Zócalo y cabezal de hoja	(A/2)-17	90-90
2	6255		Jambas de mosquitero	H-88	45-45
2	6255		Zócalo y cabezal de mosquitero	(A/2)+2	45-45
2	6228		Tope mosquitero	H-100	90-90

# Módena2 / puerta corrediza corte a 90° de 2 hojas

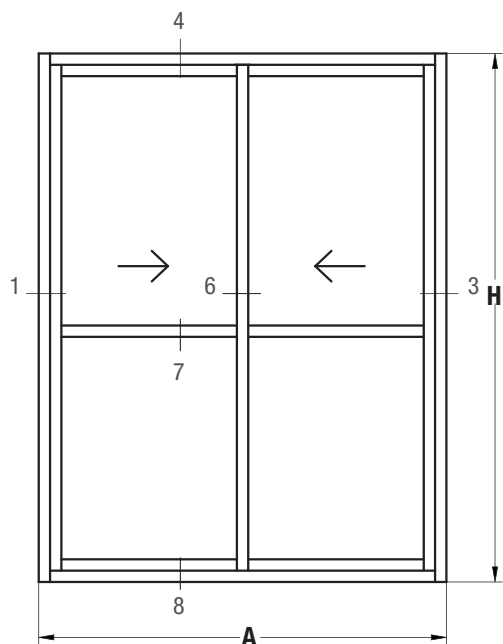
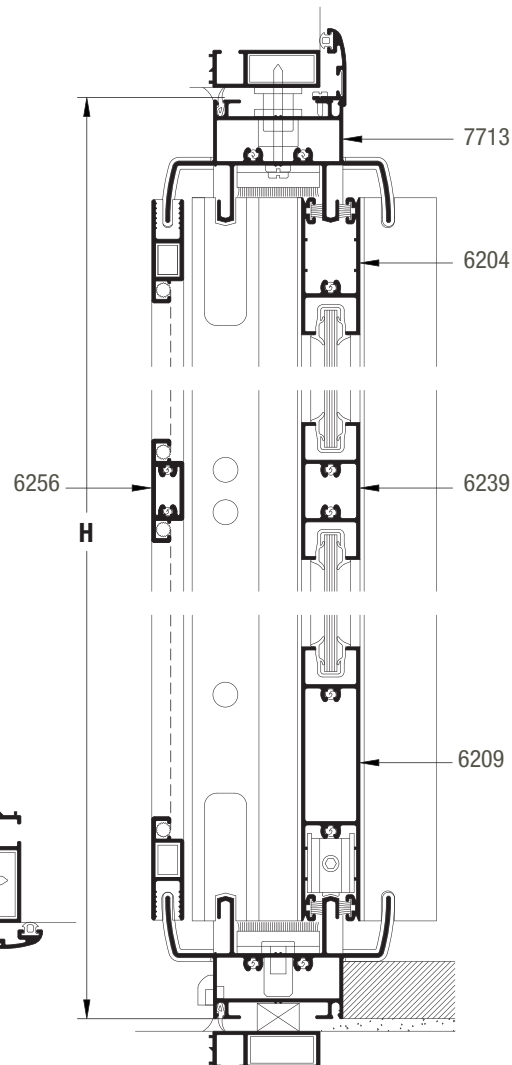
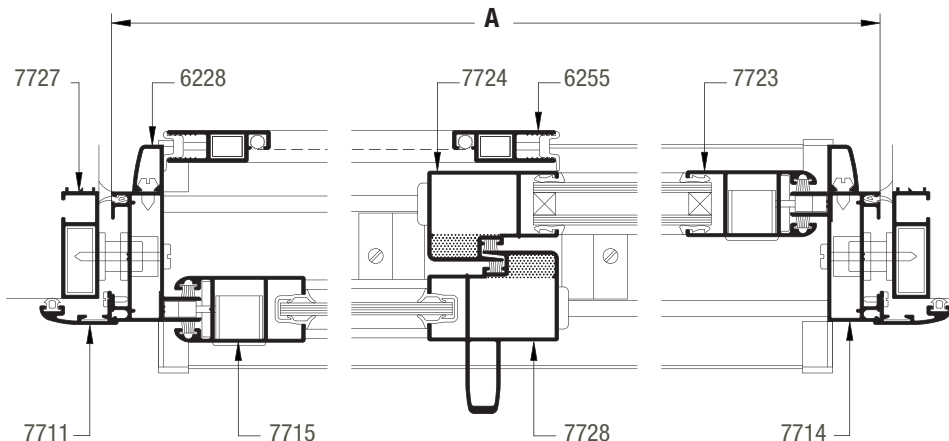
**SECCION 4-7-8**

**SECCION 1-6-3**

## Dimensión de corte de perfiles

(\*) Replantear en la abertura armada A ancho total del marco H altura total del marco

cantidad de piezas PC2	perfil		descripción	medida mm	corte
	VS	DVH			
2	7727		Jambas premarco	H+40	45-45
2	7727		Umbral y dintel premarco	A+40	45-45
2	7711		Jambas tapa premarco	(*)	45-90
2	7711		Dintel tapa premarco	A+58	45-45
2	7714		Jamba de marco	H	90-90
2	7713		Umbral y dintel de marco	A-42	90-90
2	7715	7723	Parante lateral de hoja	H-79	90-90
2	6204	6249	Cabezal de hoja	(A/2)-17	90-90
1	7716	7724	Parante central	H-79	90-90
1	7728	7725	Parante central con tirador	H-79	90-90
2	6209	6252	Zócalo alto	(A/2)-17	90-90
2	6239	6253	Travesaño de hoja	(A/2)-74	90-90
2	6255		Zócalo y cabezal de mosquitero	(A/2)+2	45-45
2	6255		Jambas de mosquitero	H-88	45-45
1	6256		Travesaño de mosquitero	(A/2)-63	90-90
2	6228		Tope mosquitero	H-100	90-90

**Módena2** / ventana y puerta corrediza corte a 90°  
de 2 hojas

**SECCION 4**

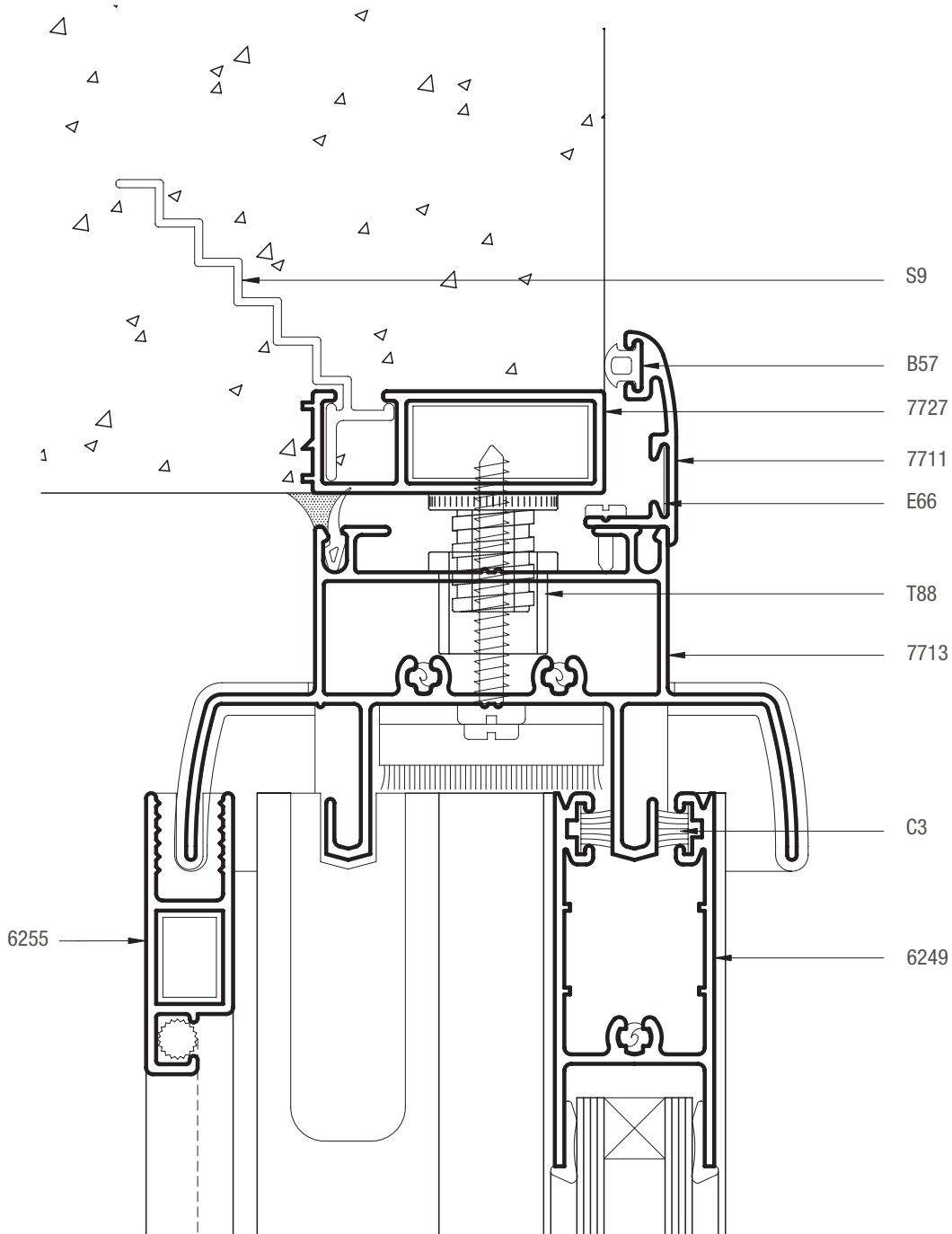

# Módena2 / ventana y puerta corrediza corte a 90° de 2 hojas



## SECCION 5

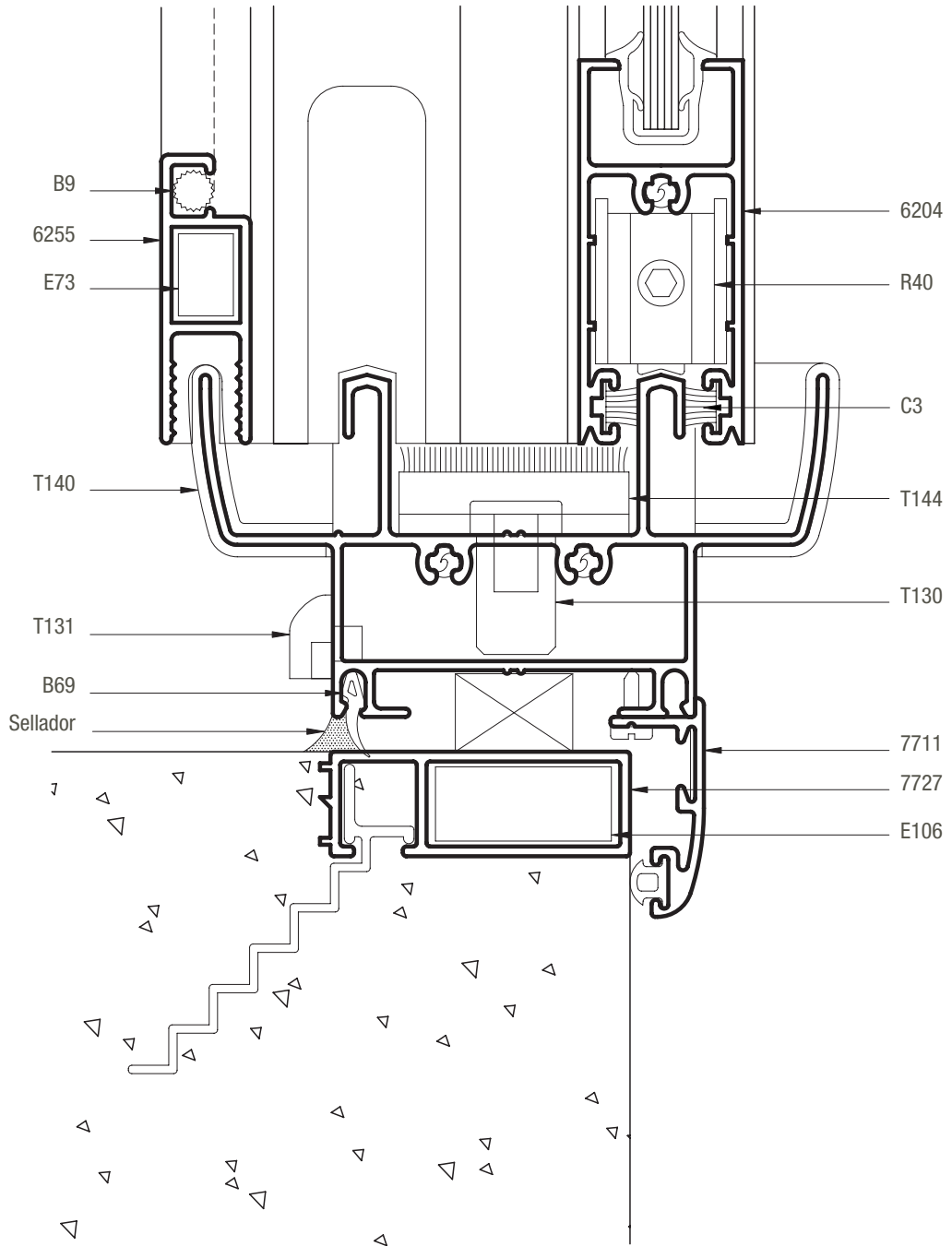

# Módena2 / ventana y puerta corrediza corte a 90° de 2 hojas

## SECCION 7

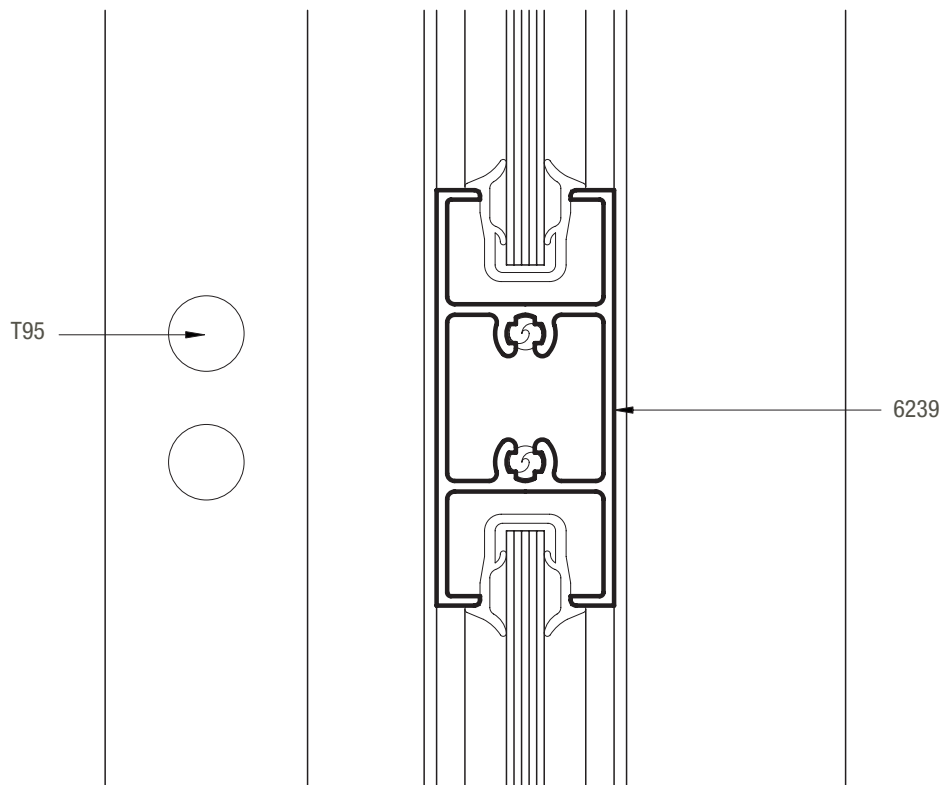

SECCION 8

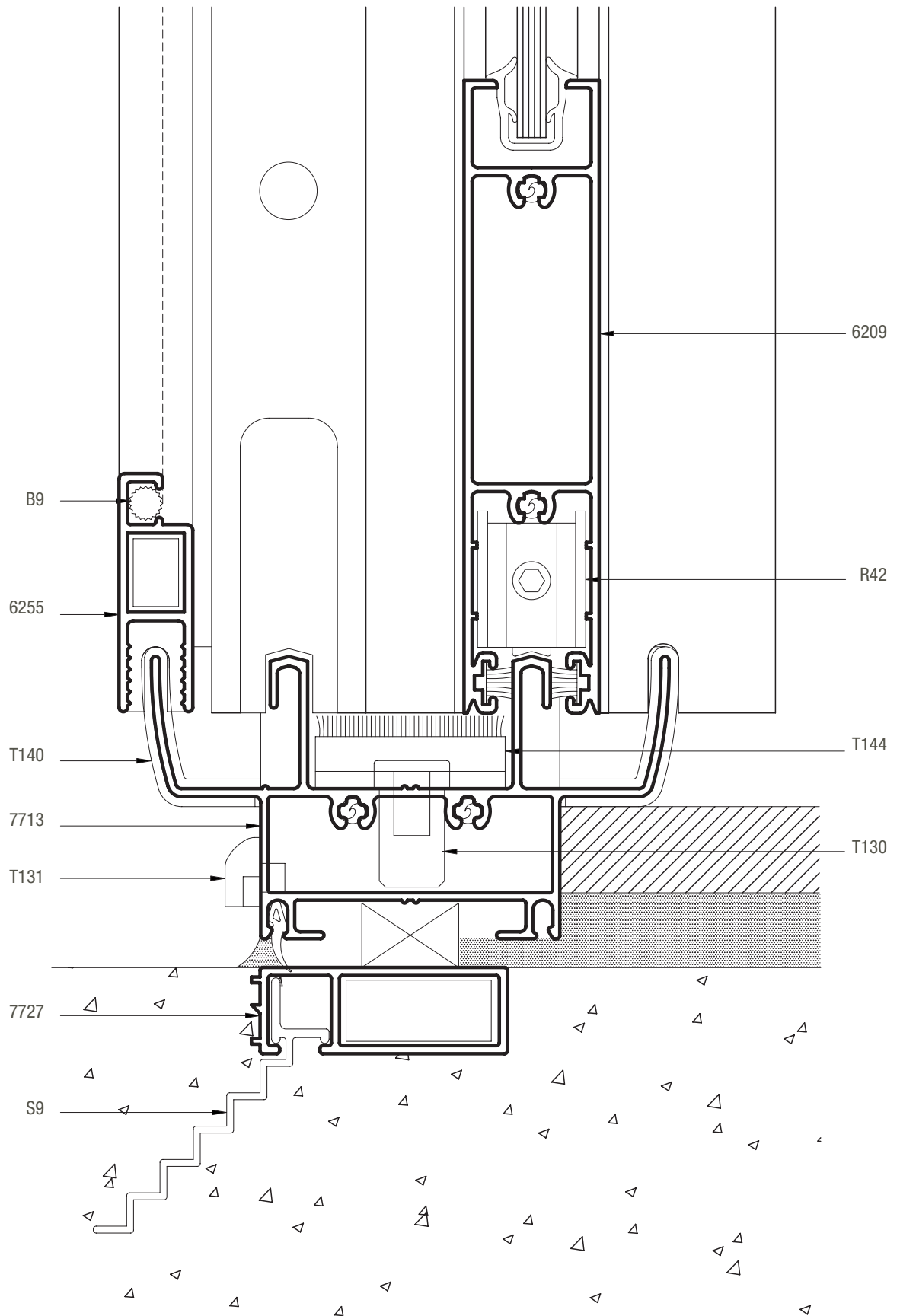

SECCION 1-2-3

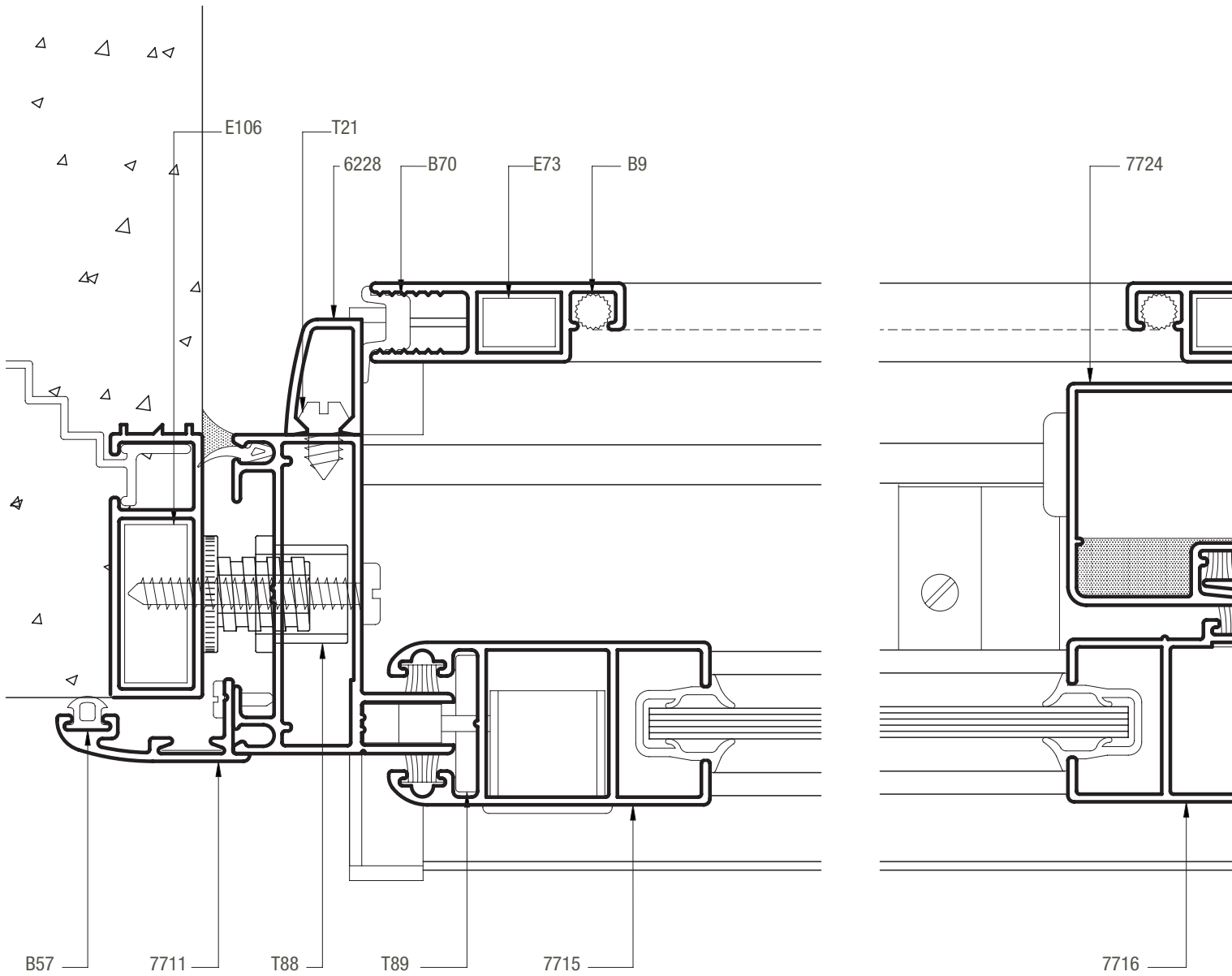

# Módena2 / ventana corrediza corte a 90° de 2 hojas

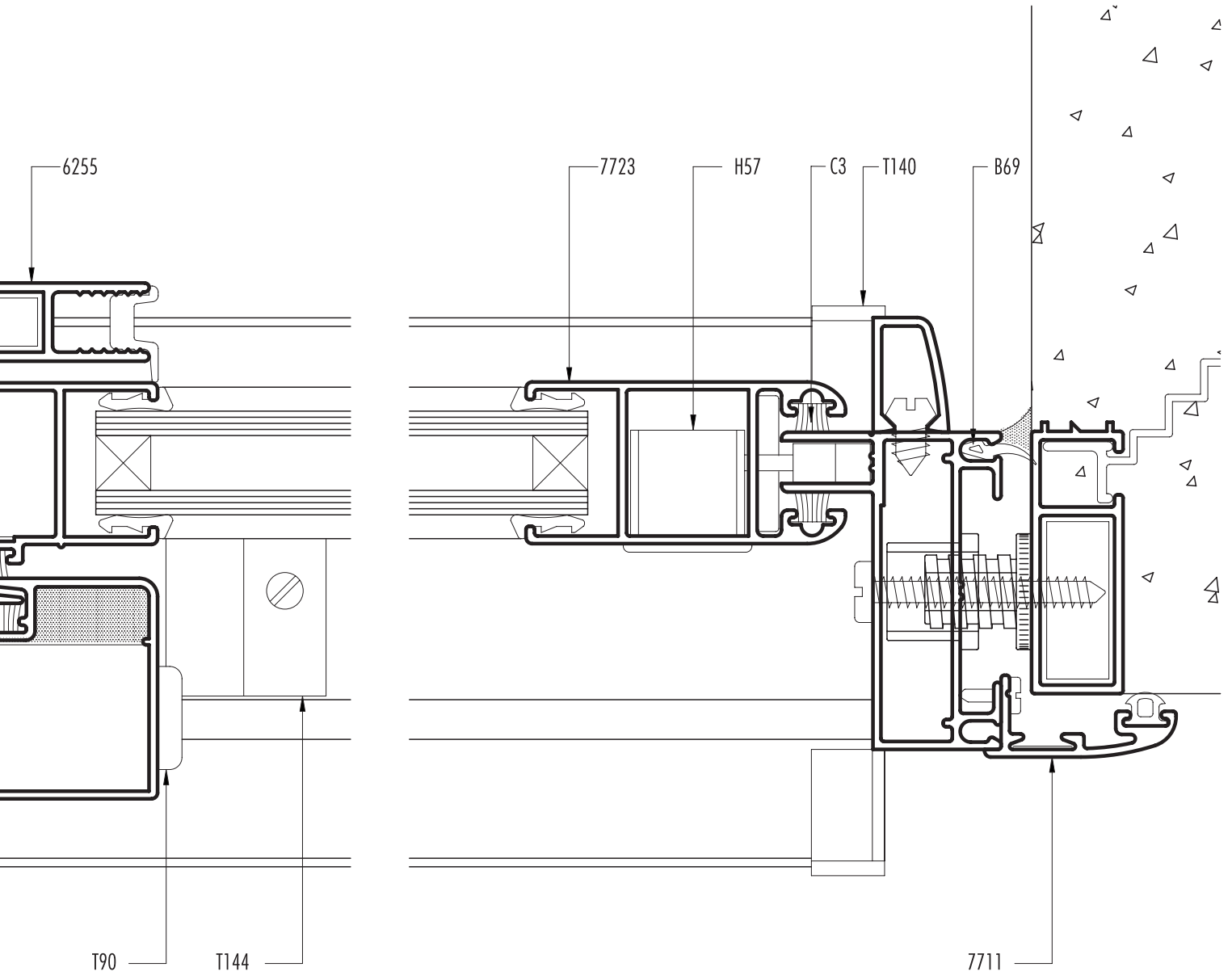

SECCION 6

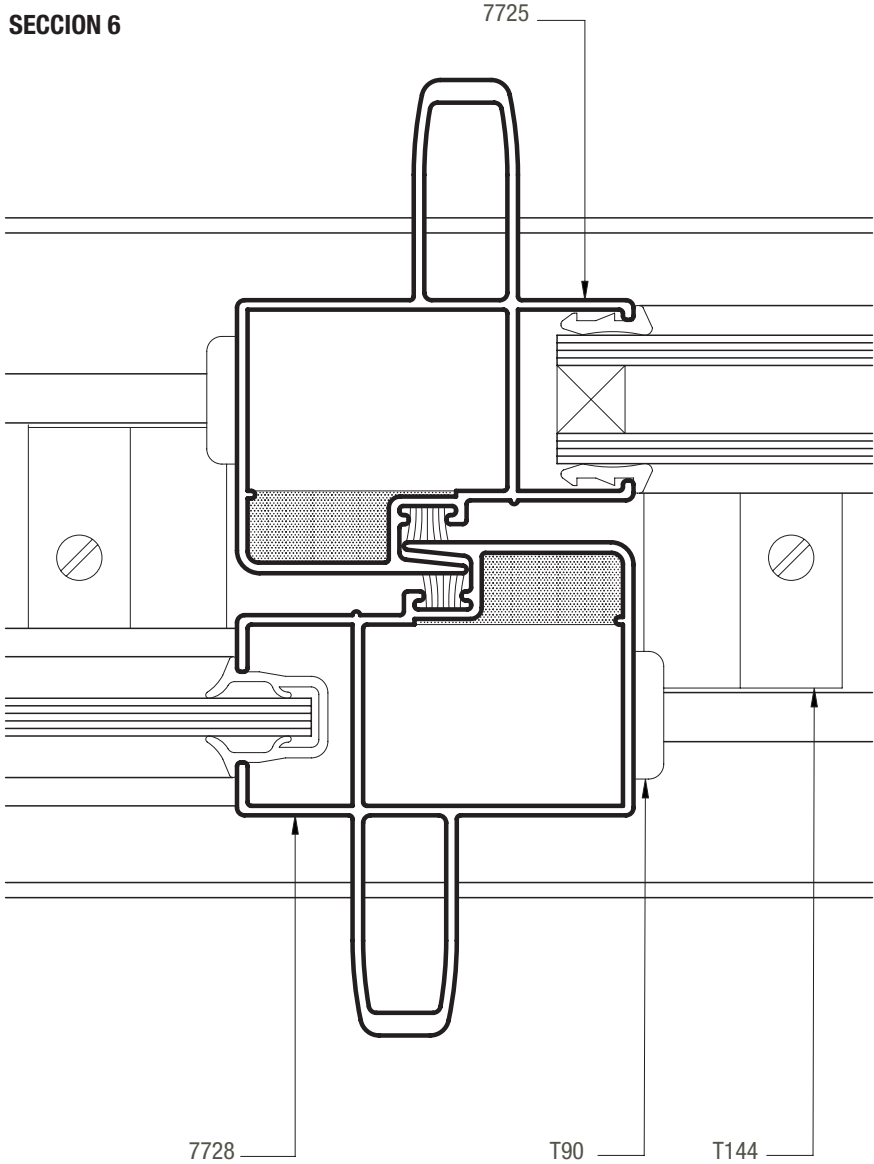

**Módena2 / ventana y puearta corrediza corte a 90°  
de 2 hojas**

**SECCION 1**

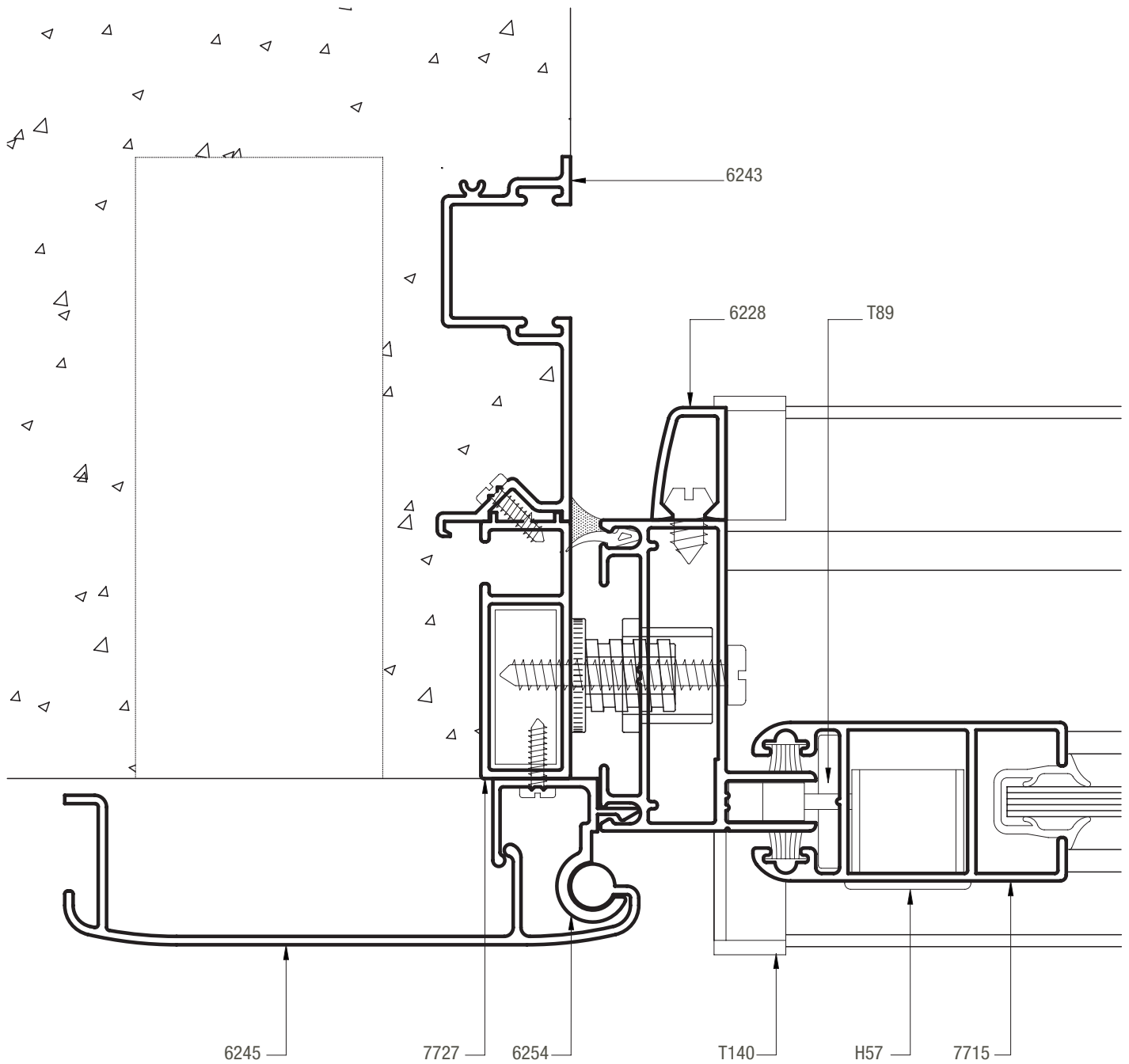

# Módena2 / ventana y puerta corrediza corte a 90° de 3 hojas

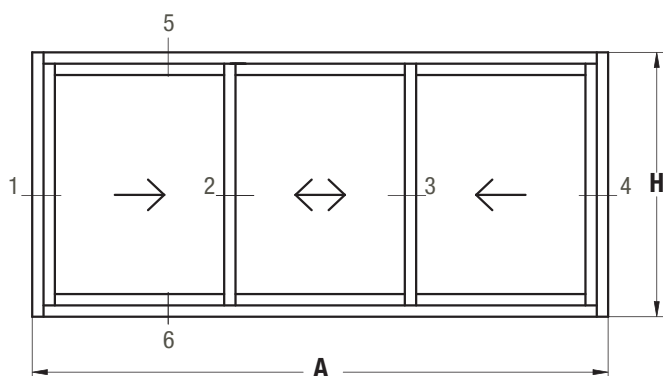

SECCION 5-6

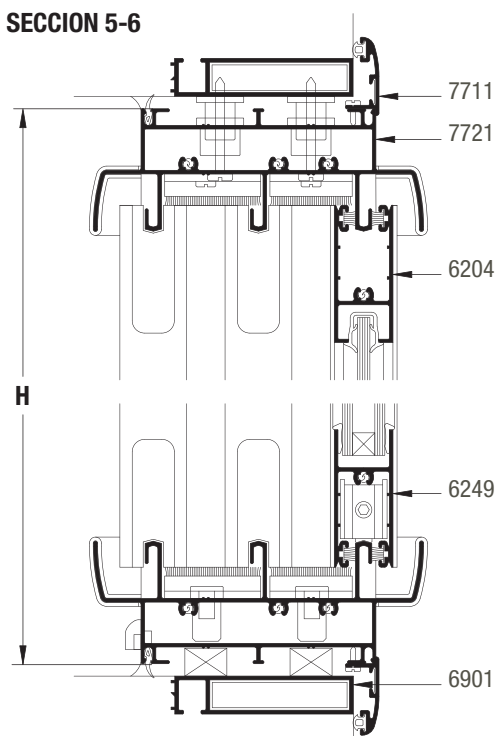

SECCION 1-2-3-4

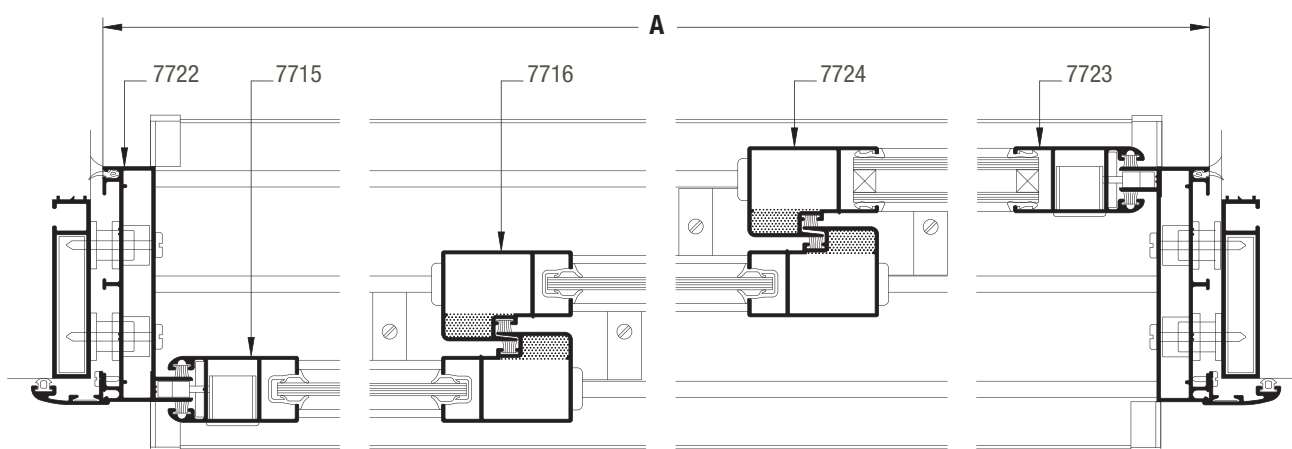

## Dimensión de corte de perfiles

(\*) Replantear en la abertura armada. A ancho total del marco H altura total del marco

cantidad de piezas		perfil		descripción	medida mm	corte
VC3	PC3	VS	DVH			
2	2		6901	Jambas premarco	H+40	45-45
2	2		6901	Umbral y dintel premarco	A+40	45-45
2			7711	Jambas tapa premarco	H+58	45-45
2	1		7711	Umbral y dintel tapa premarco	A+58	45-45
	2		7711	Jamba tapa premarco	(*)	45-90
2	2		7722	Jamba de marco	H	90-90
2	2		7721	Umbral y dintel de marco	A-42	90-90
2	2	7715	7723	Parante lateral hoja	H-79	90-90
	2	7728	7725	Parante central reforzado	H-79	90-90
4	2	7716	7724	Parante central hoja	H-79	90-90
6	3	6204	6249	Zócalo y cabezal de hoja	(A/3)+6	90-90
	3	6209	6252	Zócalo alto	(A/3)+6	90-90
	2	6239	6253	Travesaño de hoja lateral	(A/3)-51	90-90
	1	6239	6253	Travesaño de hoja central	(A/3)-66	90-90

**Módena2** / ventana y puerta corrediza corte a 90°  
de 3 hojas

**SECCION 6**

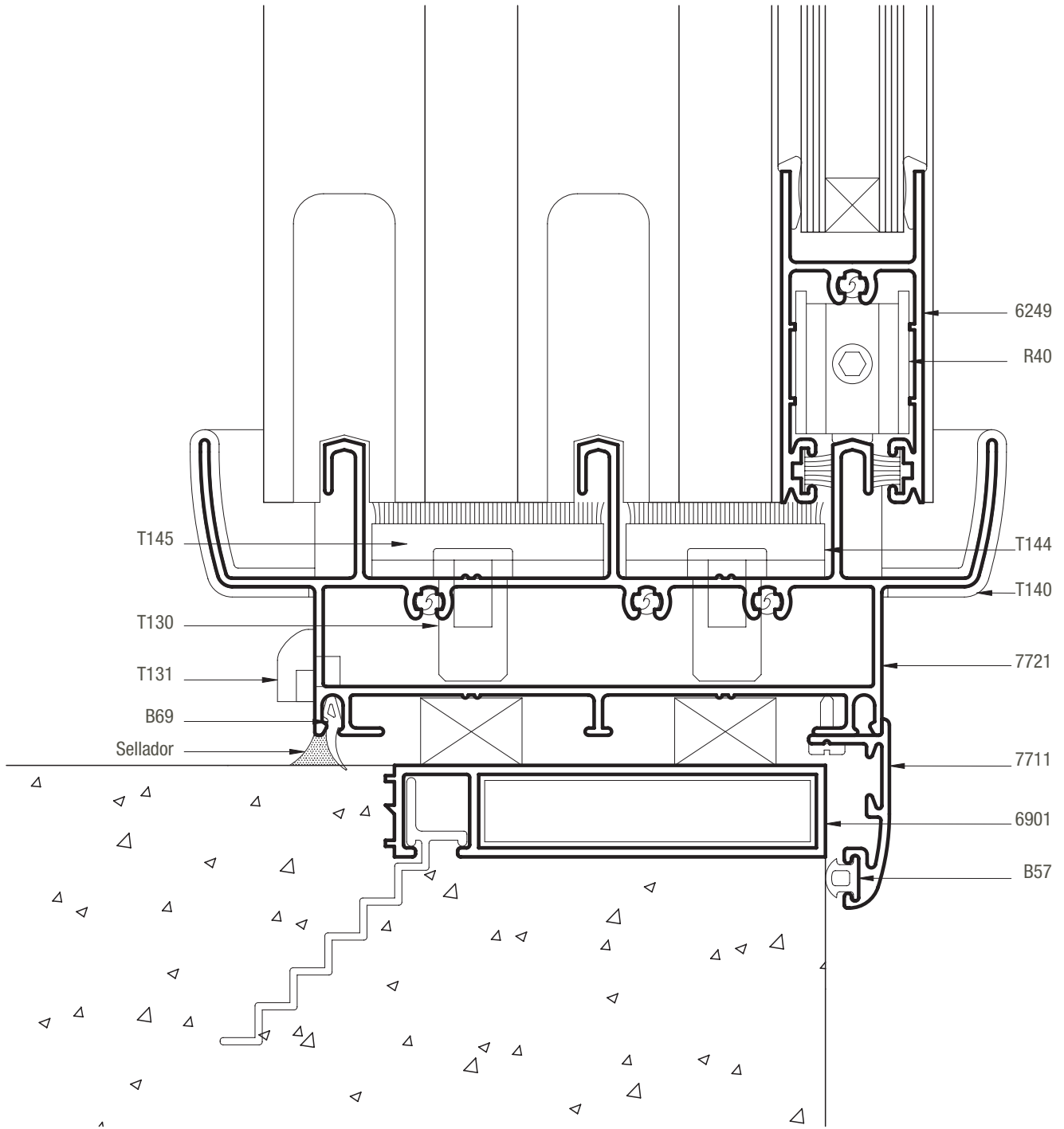

**Módena2** / ventana y puerta corrediza corte a 90°  
de 3 hojas

**SECCION 1-2**

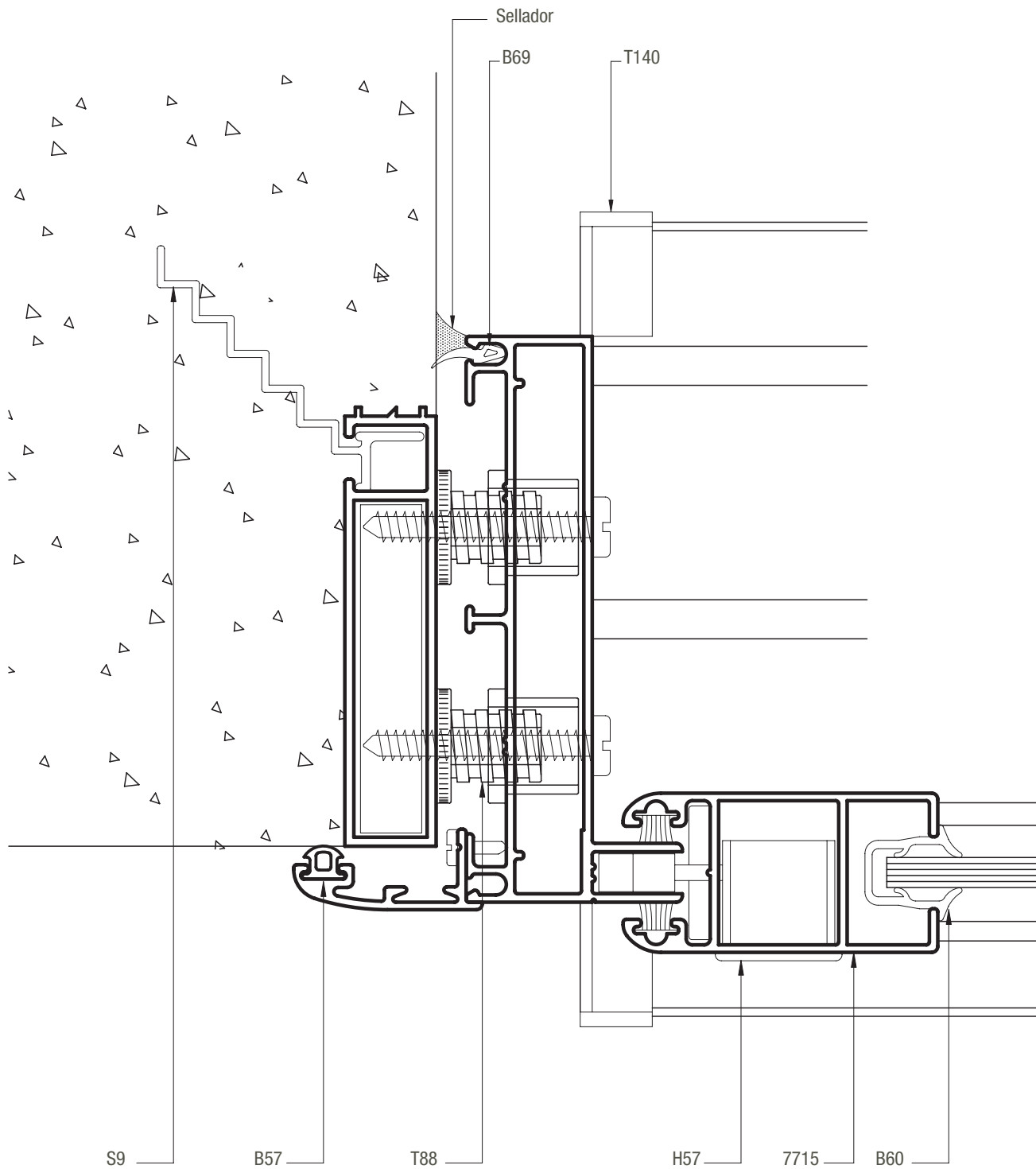

# Módena2 / ventana y puerta corrediza corte a 90° de 3 hojas

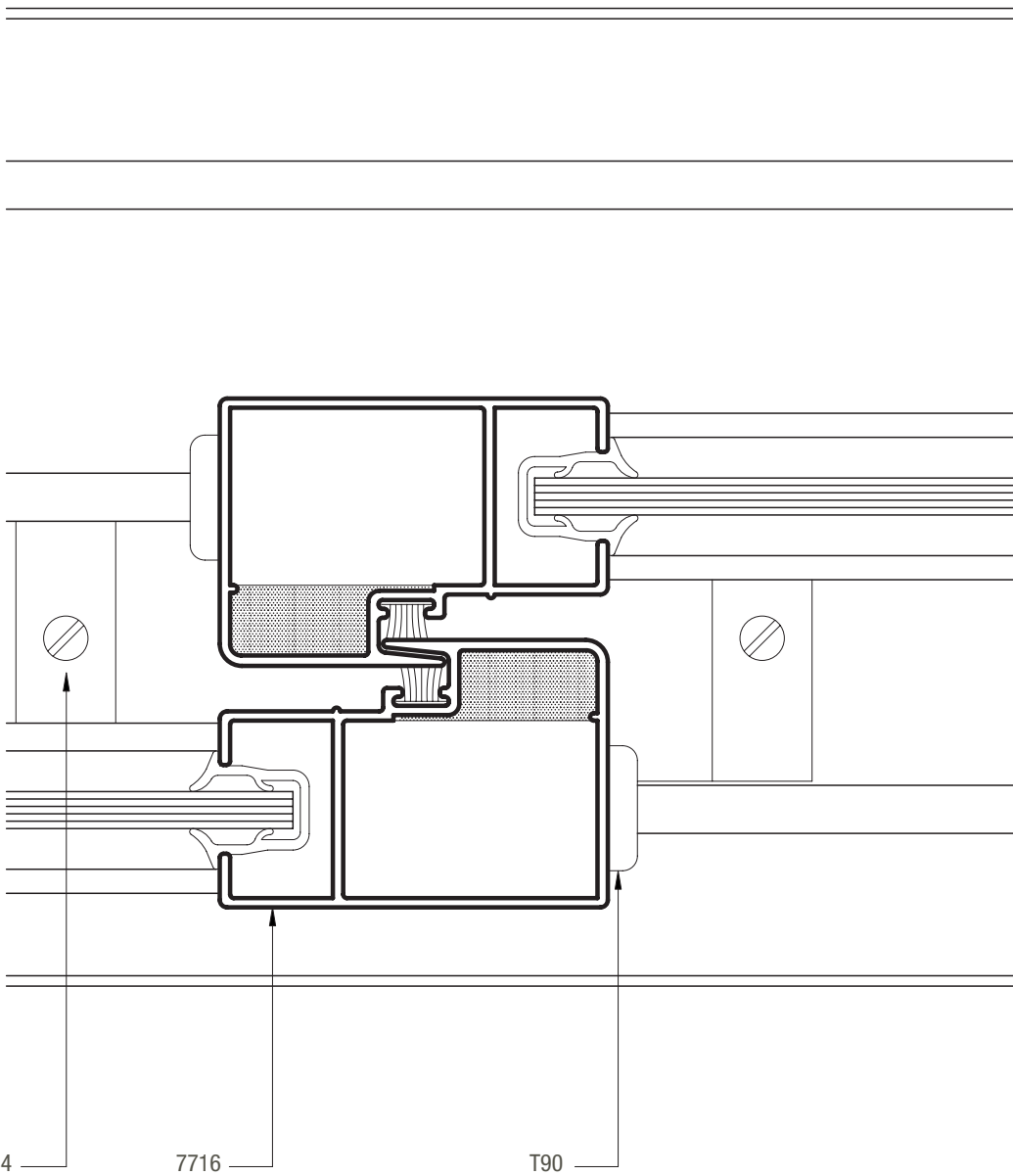

# Módena2 / ventana y puerta corrediza corte a 90° de 3 hojas

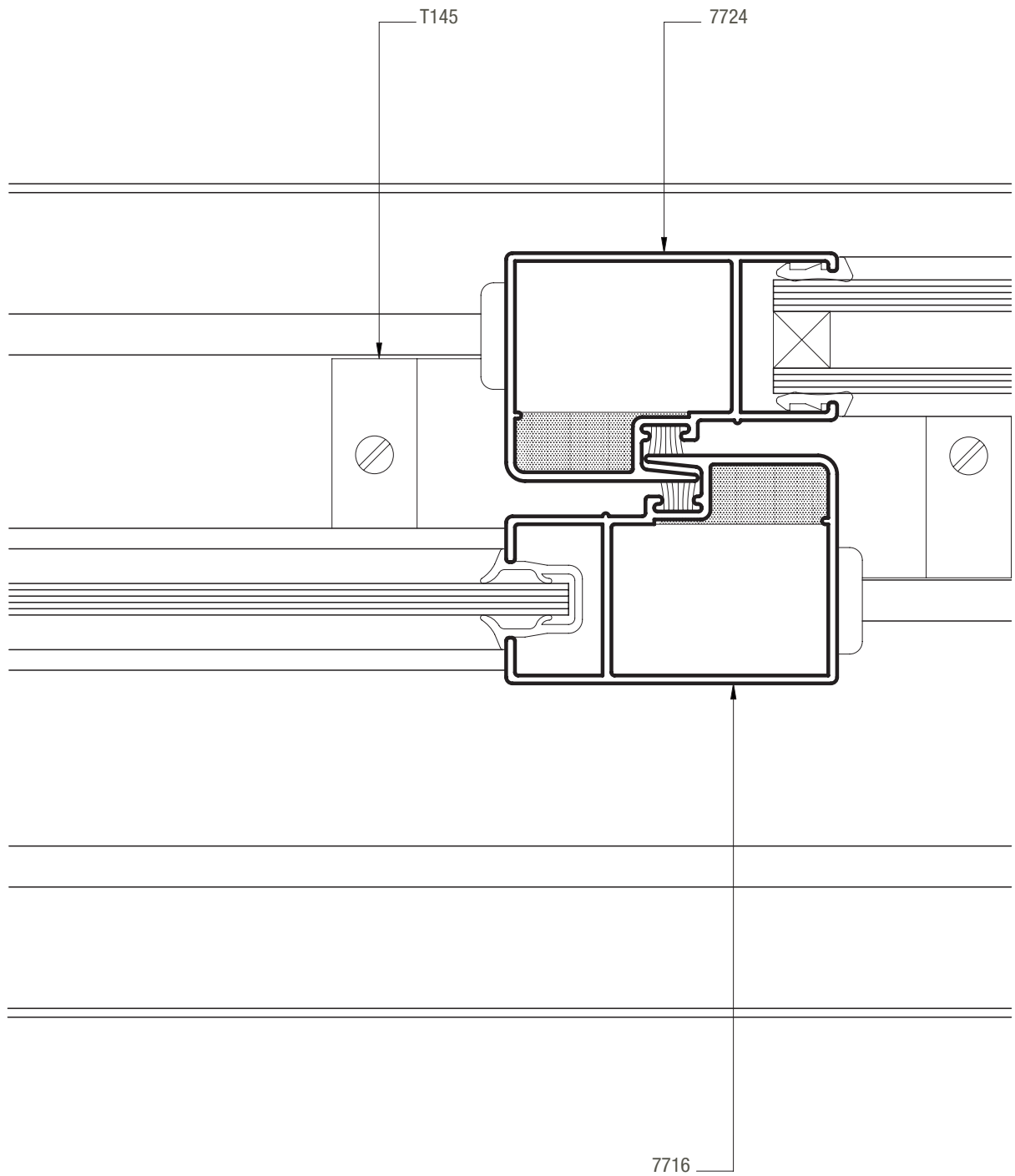

# Módena2 / ventana y puerta corrediza corte a 90° de 3 hojas

## SECCION 3-4

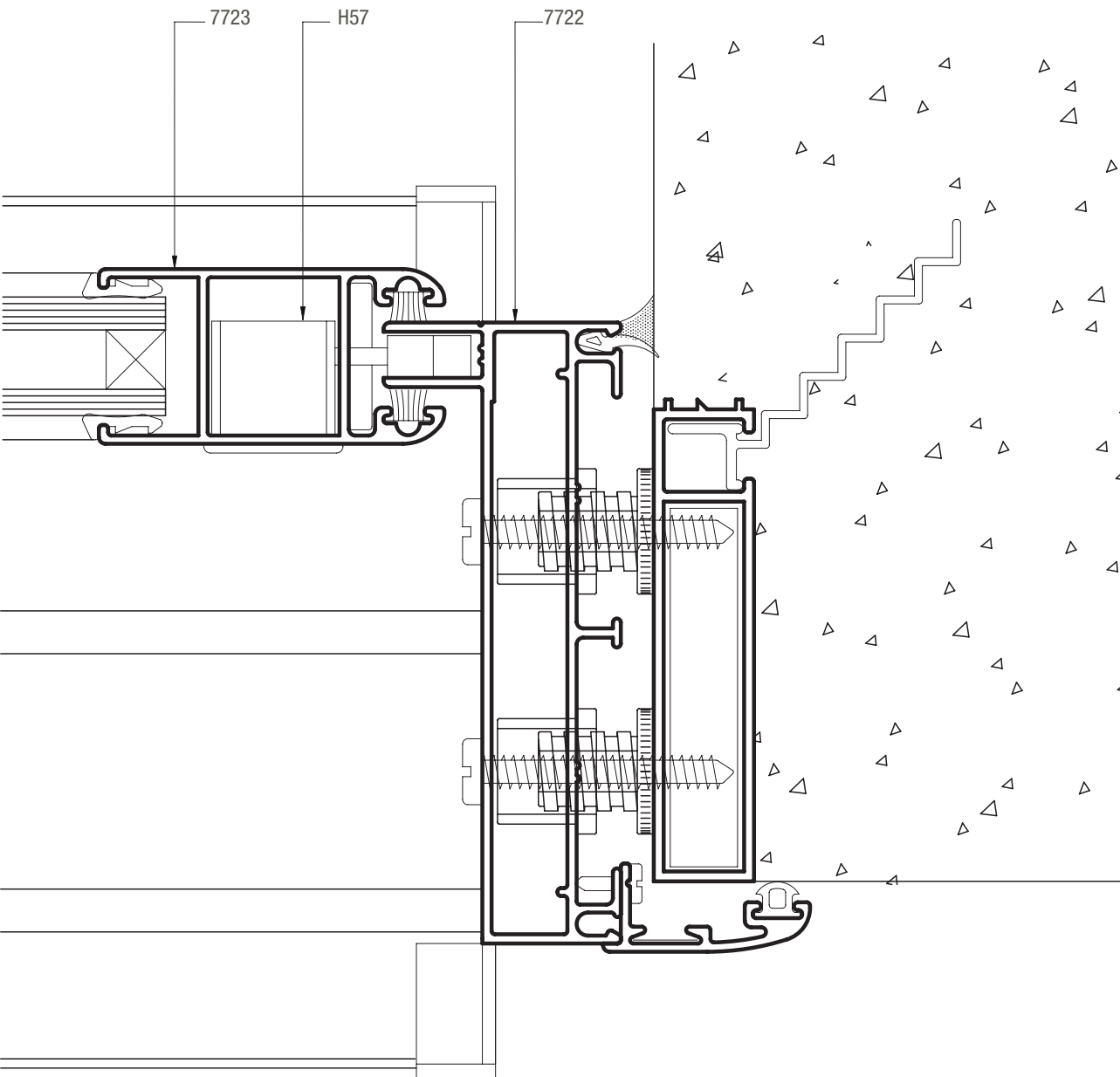

# Módena2 / ventana y puerta corrediza corte a 90° de 4 hojas

SECCION 6-7

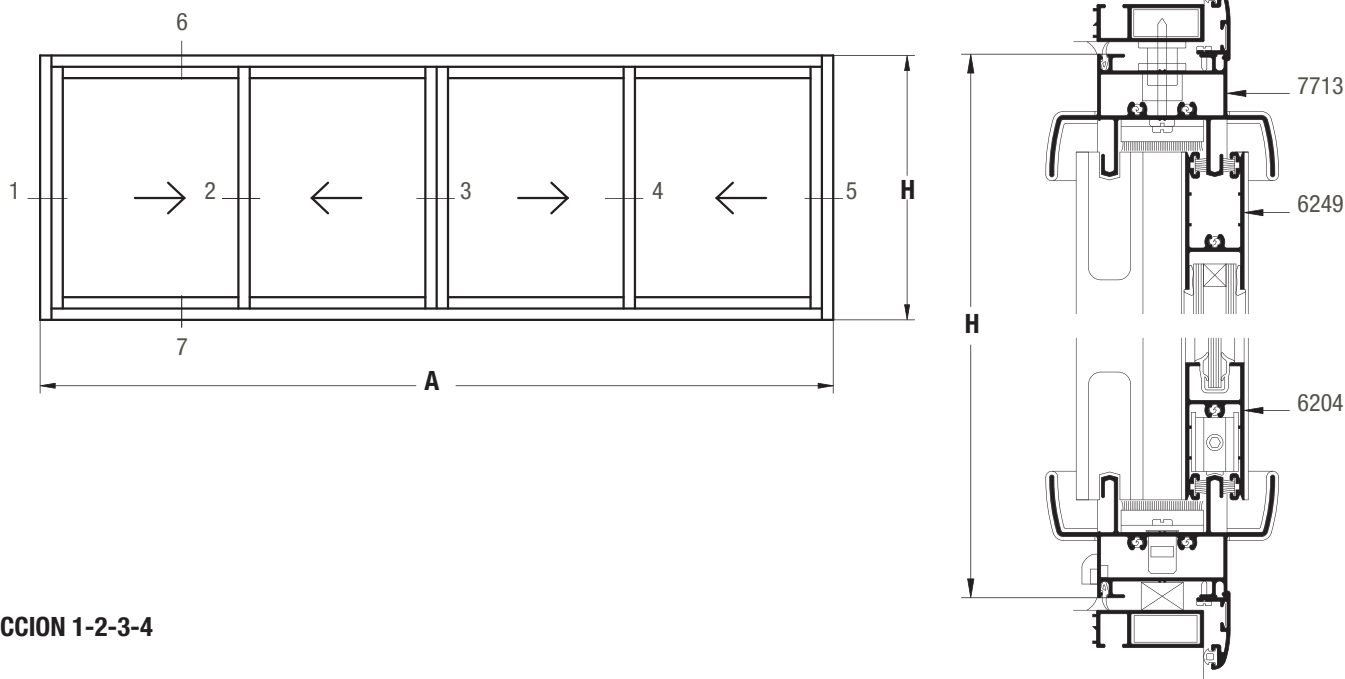

SECCION 1-2-3-4

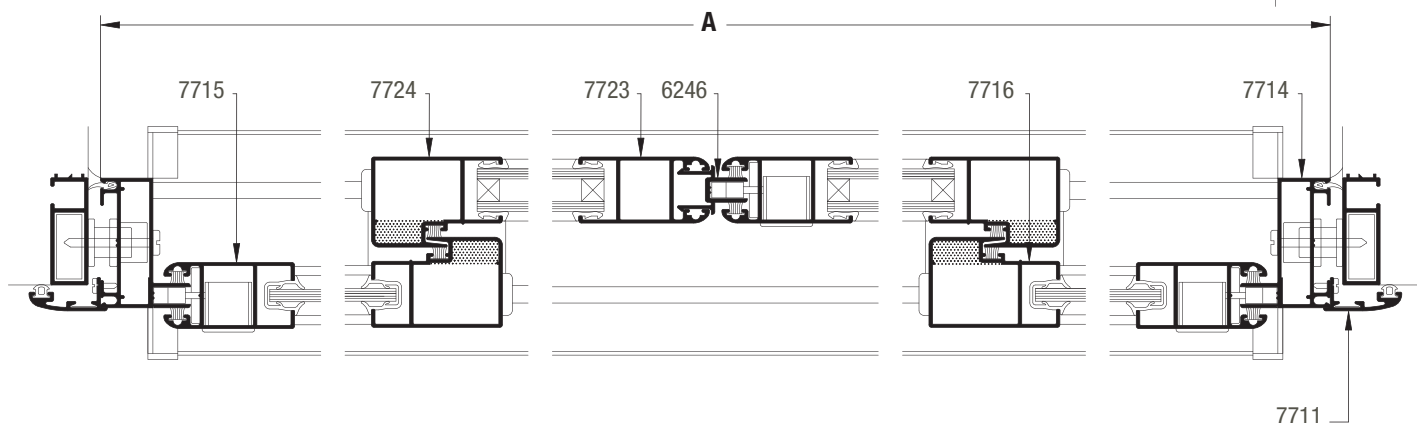

## Dimensión de corte de perfiles

(\*) Replantear en la abertura armada. A ancho total del marco H altura total del marco

cantidad de piezas		perfil		descripción	medida mm	corte
VC4	PC4	VS	DVH			
2	2		7727	Jambas premarco	H+40	45-45
2	2		7727	Umbral y dintel premarco	A+40	45-45
2			7711	Jambas tapa premarco	H+58	45-45
2	1		7711	Umbral y dintel tapa premarco	A+58	45-45
	2		7711	Jamba tapa premarco	(*)	45-90
2	2		7714	Jamba de marco	H	90-90
2	2		7713	Umbral y dintel de marco	A-42	90-90
4	4	7715	7723	Parante lateral hoja	H-79	90-90
	2	7728	7725	Parante central reforzado	H-79	90-90
4	2	7716	7724	Parante central hoja	H-79	90-90
8	4	6204	6249	Zócalo y cabezal de hoja	(A/4)-5	90-90
	4	6209	6252	Zócalo alto	(A/4)-5	90-90
	4	6239	6253	Travesaño de hoja	(A/4)-63	90-90
1	1		6246	Encuentro central 4 hojas	H-79	90-90

# Módena2 / ventana y puerta corrediza corte a 90° de 4 hojas

## SECCION 3

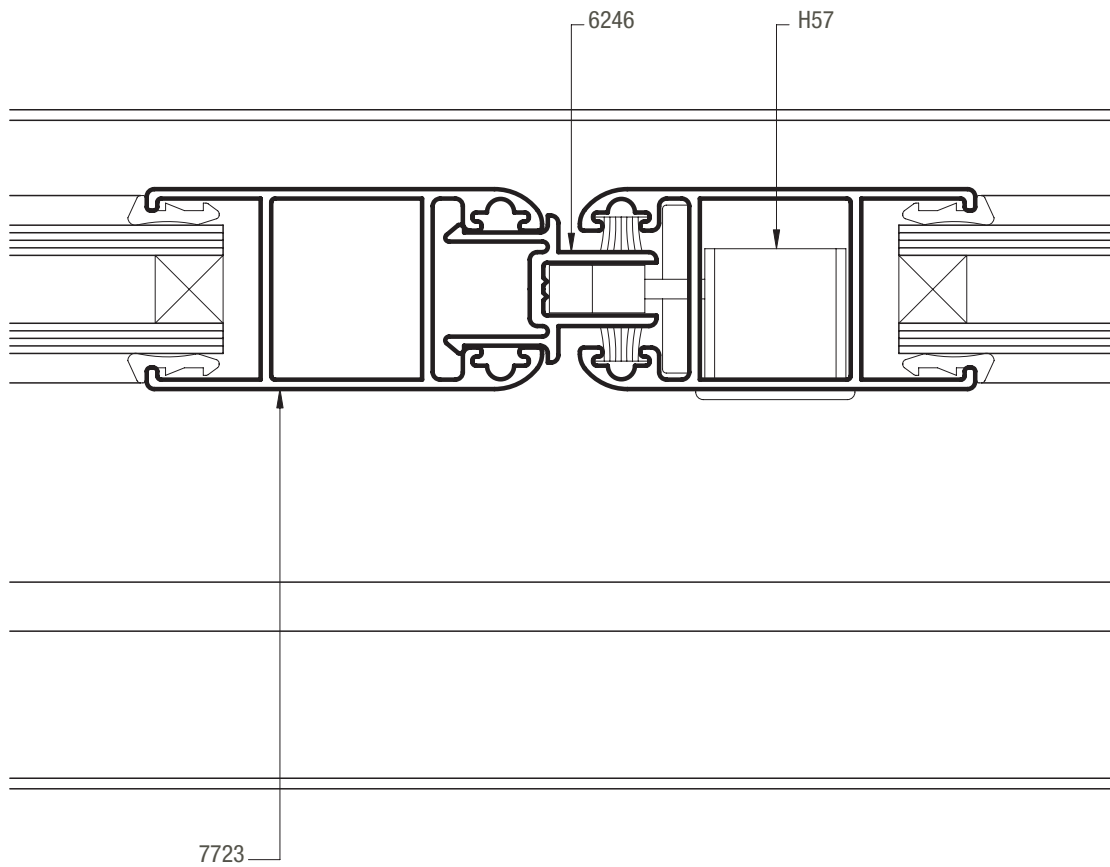

# Módena2 / ventana y puerta corrediza corte a 45° de 2 hojas

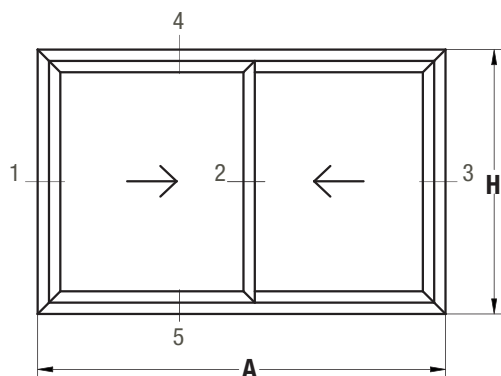
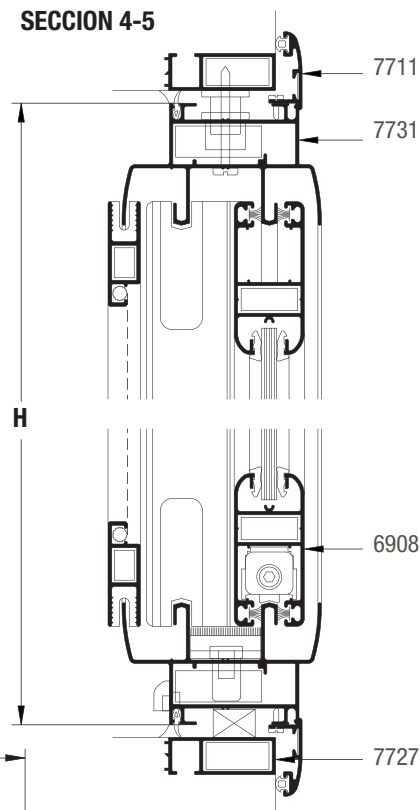
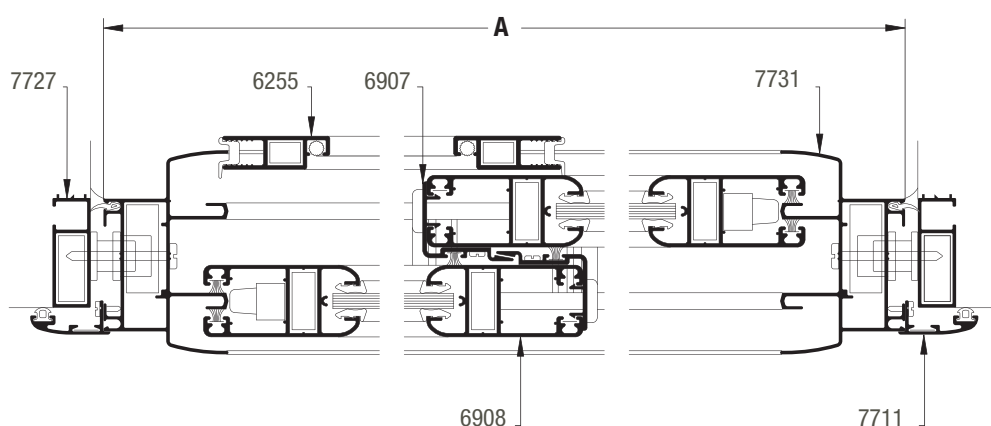
**SECCION 4-5**

**SECCION 1-2-3**

## Dimensión de corte de perfiles

 (\*) Replantear en la abertura armada **A** ancho total del marco **H** altura total del marco

cantidad de piezas		perfil		descripción	medida mm	corte
VC2	PC2	VS	DVH			
2	2	7727		Jambas premarco	H+40	45-45
2	2	7727		Umbral y dintel premarco	A+40	45-45
2		7711		Jambas tapa premarco	H+58	45-45
2	1	7711		Umbral y dintel tapa premarco	A+58	45-45
	2	7711		Jamba tapa premarco	(*)	45-90
2	2	7731		Jamba de marco	H	45-45
2	2	7731		Umbral y dintel de marco	A	45-45
2	2	6908	6909	Parante lateral hoja	H-80	45-45
4	4	6908	6909	Zócalo y cabezal de hoja	(A/2)-10	45-45
2	1	6908	6909	Parante central hoja	H-80	45-45
	1	6910	6911	Parante central reforzado	H-80	45-45
2	2	6907		Suplemento parante central	H-80	90-90
2	2	6255		Jambas mosquitero	H-88	45-45
2	2	6255		Zócalo y cabezal mosquitero	(A/2)-34	45-45
	1	6256		Travesaño mosquitero	(A/2)-100	90-90

# Módena2 / ventana y puerta corrediza corte a 45° de 2 hojas

## SECCION 5

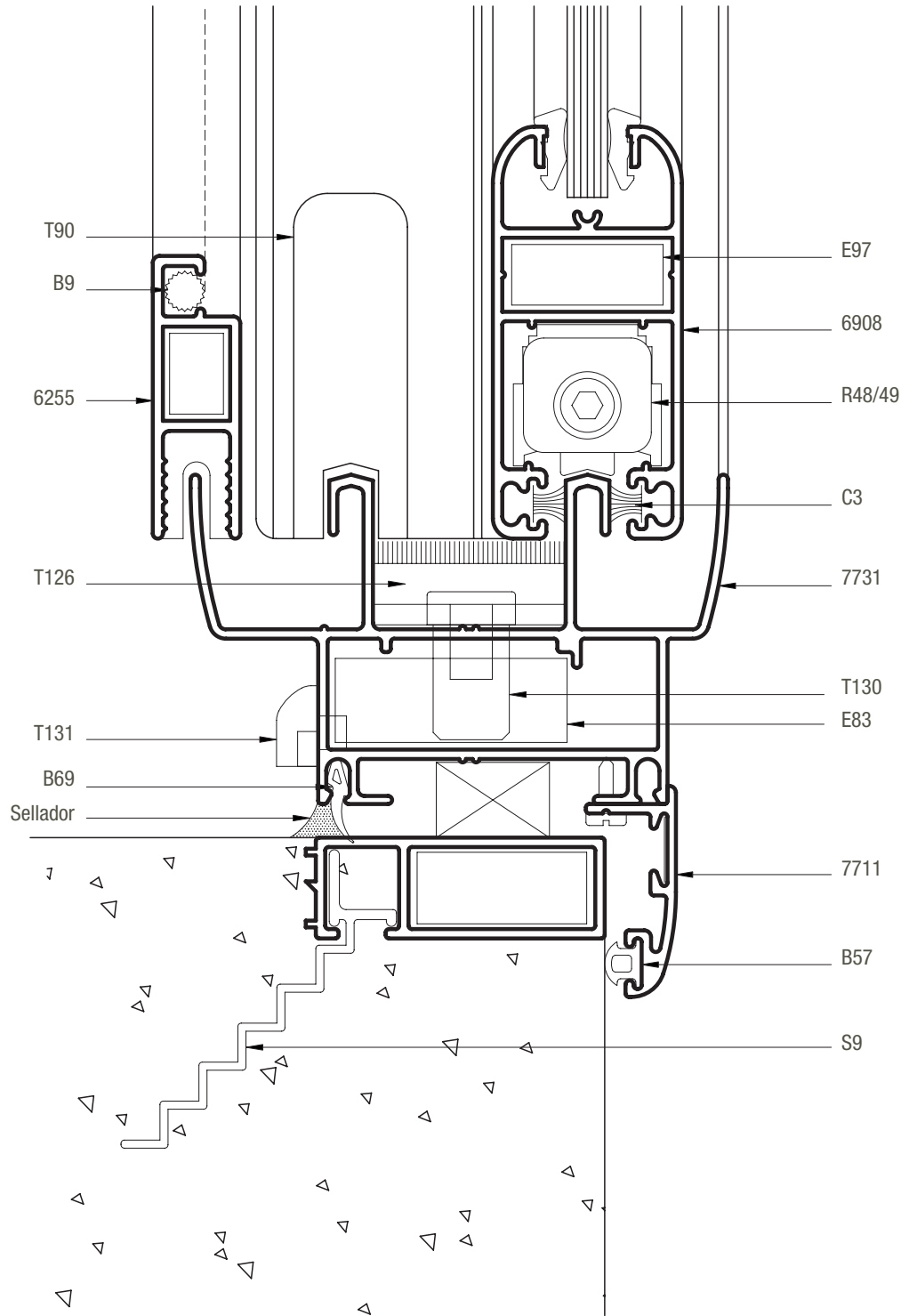

**Módena2** / ventana y puerta corrediza corte a 45°  
de 2 hojas

**SECCION 1-2-3**

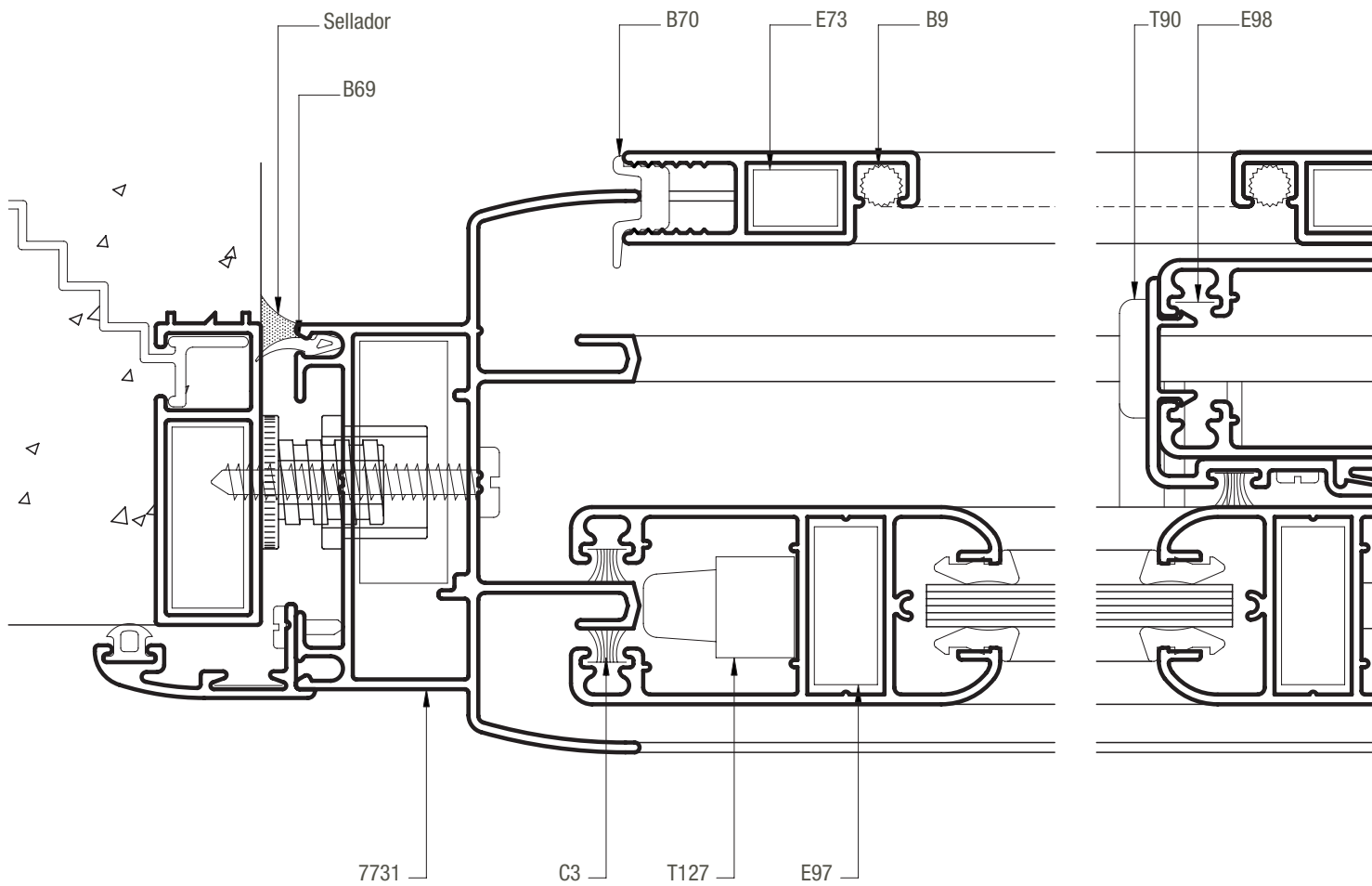

# Módena2 / ventana y puerta corrediza corte a 45° de 2 hojas

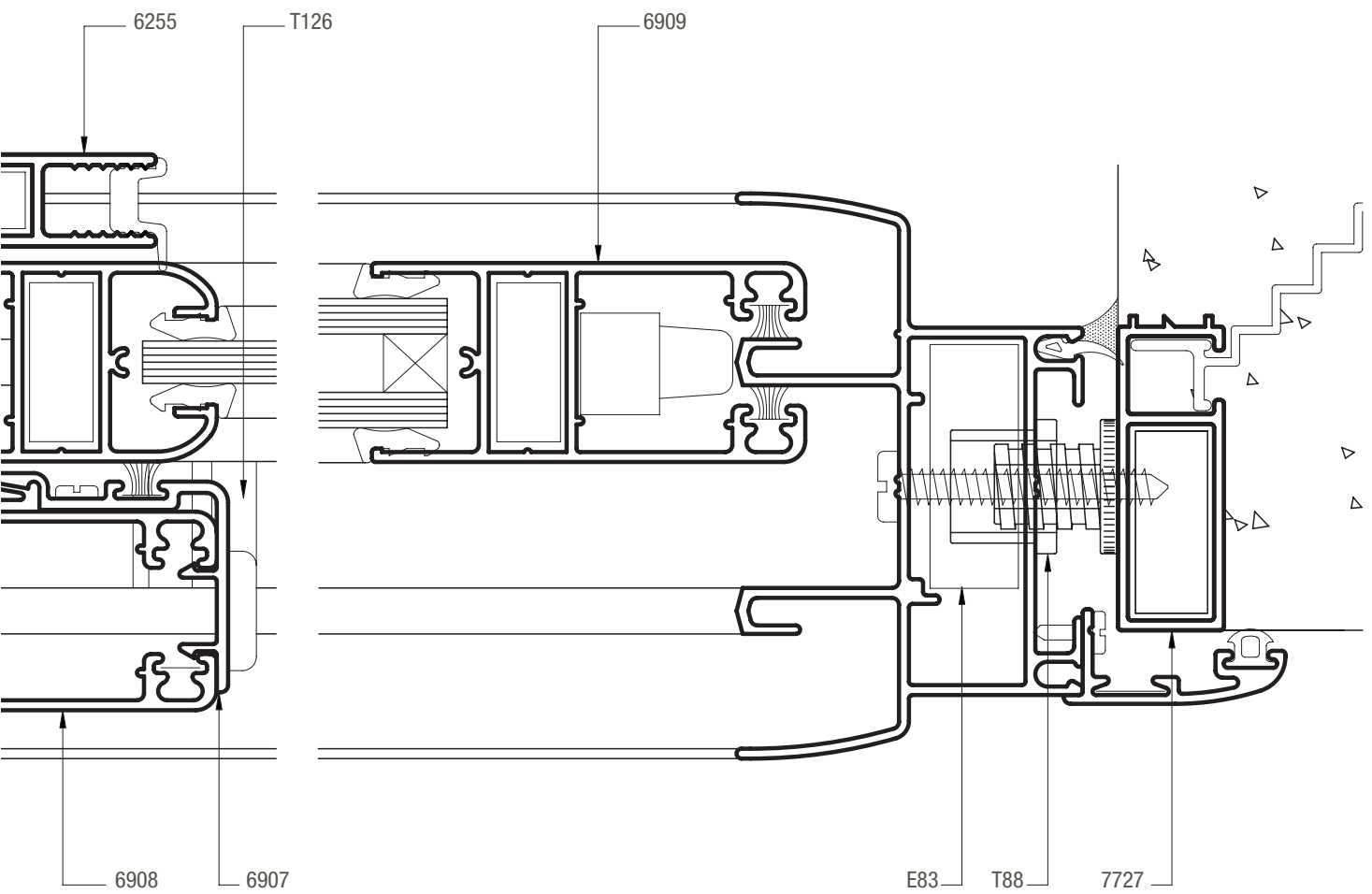

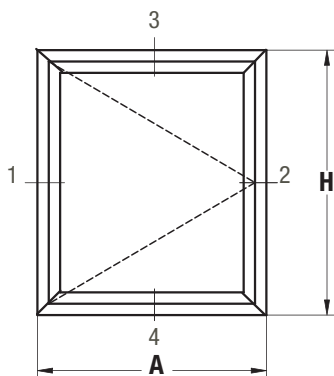

SECCION 3-4

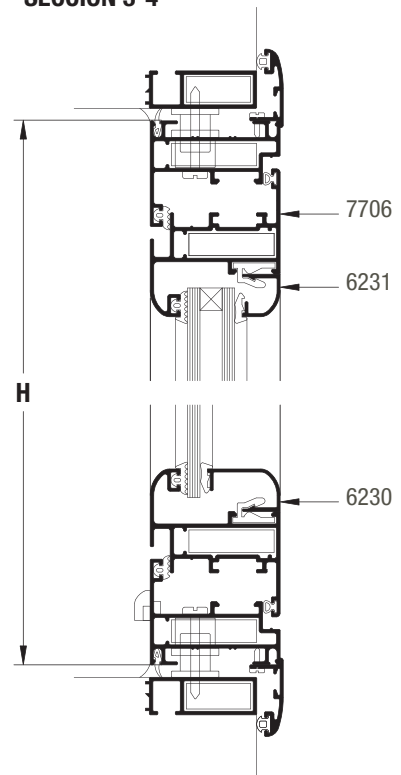

SECCION 1-2

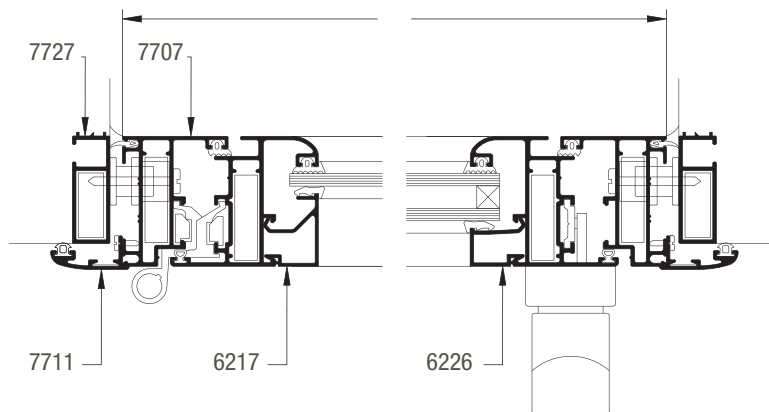

**Dimensión de corte de perfiles**

A ancho total del marco H altura total del marco

cantidad de piezas	perfil	descripción	medida mm	corte
2	7727	Jambas premarco	H+40	45-45
2	7727	Umbral y dintel premarco	A+40	45-45
2	7711	Jambas tapa premarco	H+58	45-45
2	7711	Umbral y dintel tapa premarco	A+58	45-45
2	7707	Jamba de marco	H	45-45
2	7707	Umbral y dintel de marco	A	45-45
2	7706	Jambas de hoja	H-38	45-45
2	7706	Zócalo y cabezal de hoja	A-38	45-45

# Módena2 / ventana abrir/oscilobatiente de 2 hojas coplanar

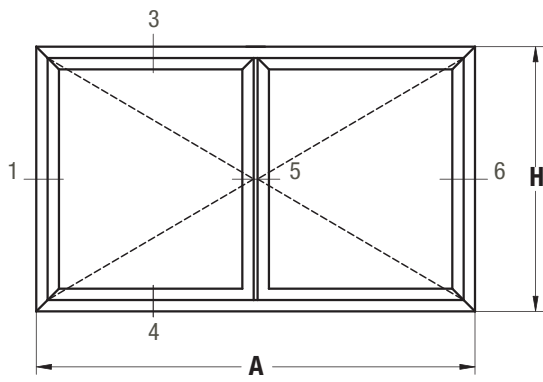

## SECCION 3-4

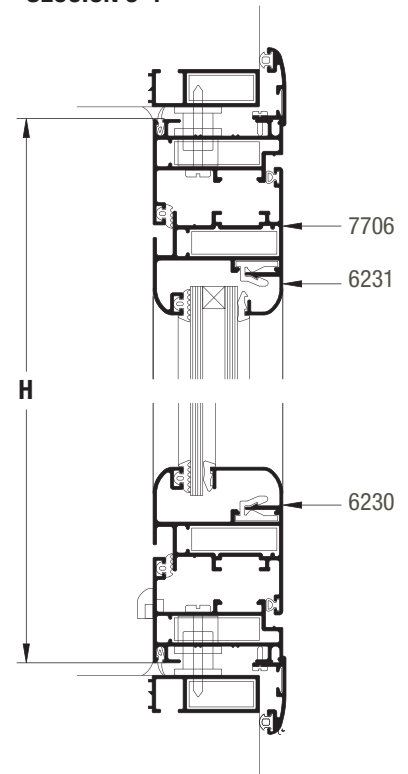

## SECCION 1-5-6

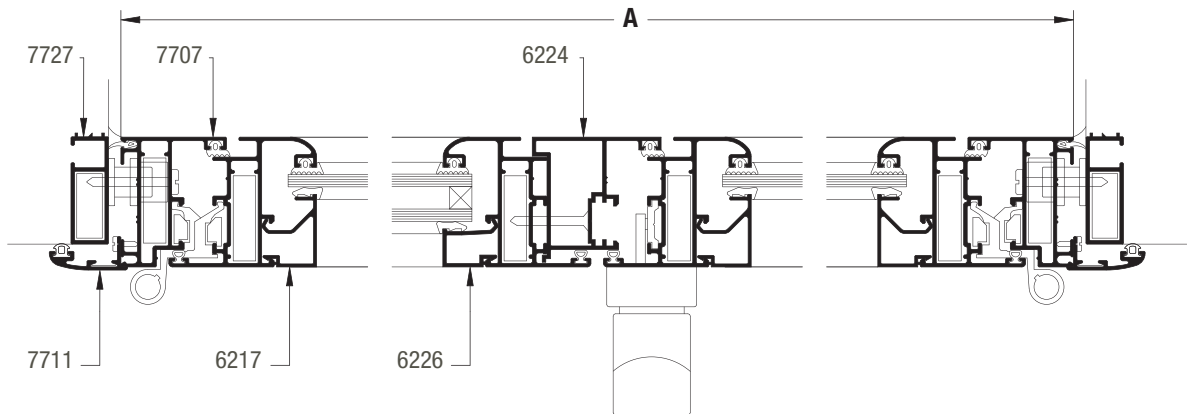

### Dimensión de corte de perfiles

A ancho total del marco H altura total del marco

cantidad de piezas	perfil	descripción	medida mm	corte
2	7727	Jambas premarco	H+40	45-45
2	7727	Umbral y dintel premarco	A+40	45-45
2	7711	Jambas tapa premarco	H+58	45-45
2	7711	Umbral y dintel tapa premarco	A+58	45-45
2	7707	Jamba de marco	H	45-45
2	7707	Umbral y dintel de marco	A	45-45
1	6224	Encuentro central 2 hojas	H-95	90-90
4	7706	Jambas de hoja	H-38	45-45
4	7706	Zócalo y cabezal de hoja	(A/2)-22	45-45

# Módena2 / ventana abrir/oscilobatiente de 1 y 2 hojas coplanar



## SECCION 3

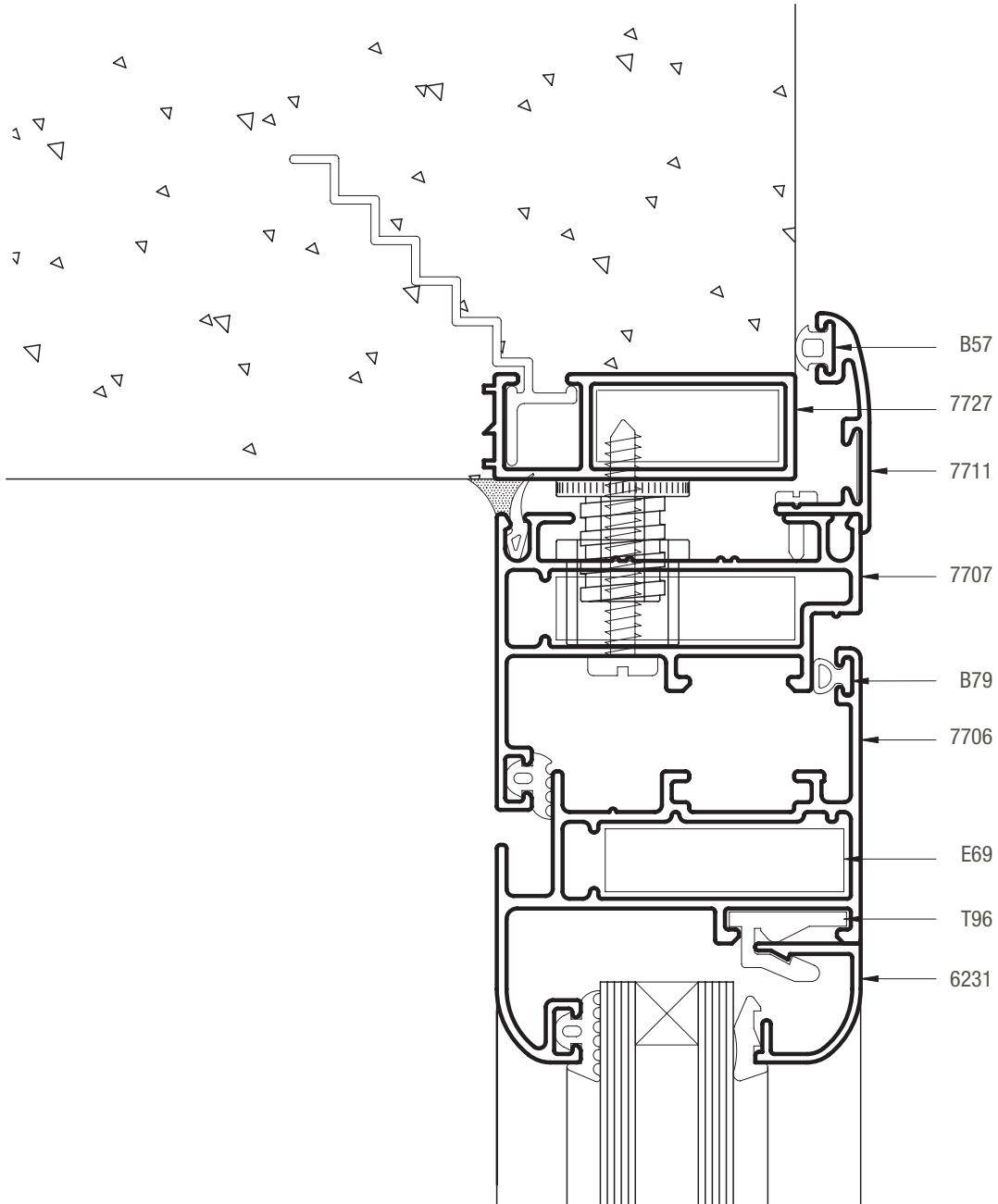

# Módena2 / ventana abrir/oscilobatiente de 1 y 2 hojas coplanar

## SECCION 4

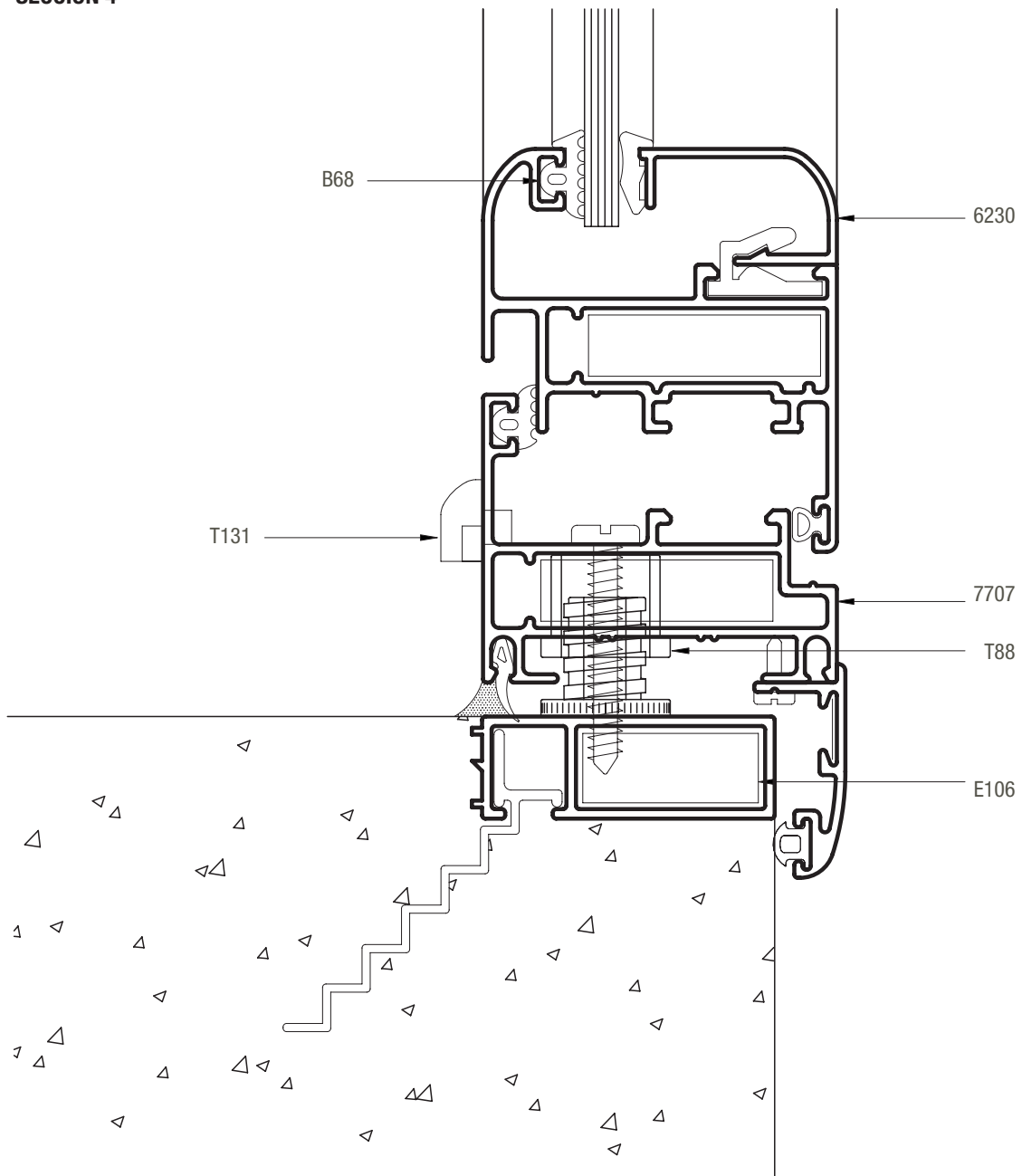

# Módena2 / ventana abrir/oscilobatiente de 1 y 2 hojas coplanar

## SECCION 1

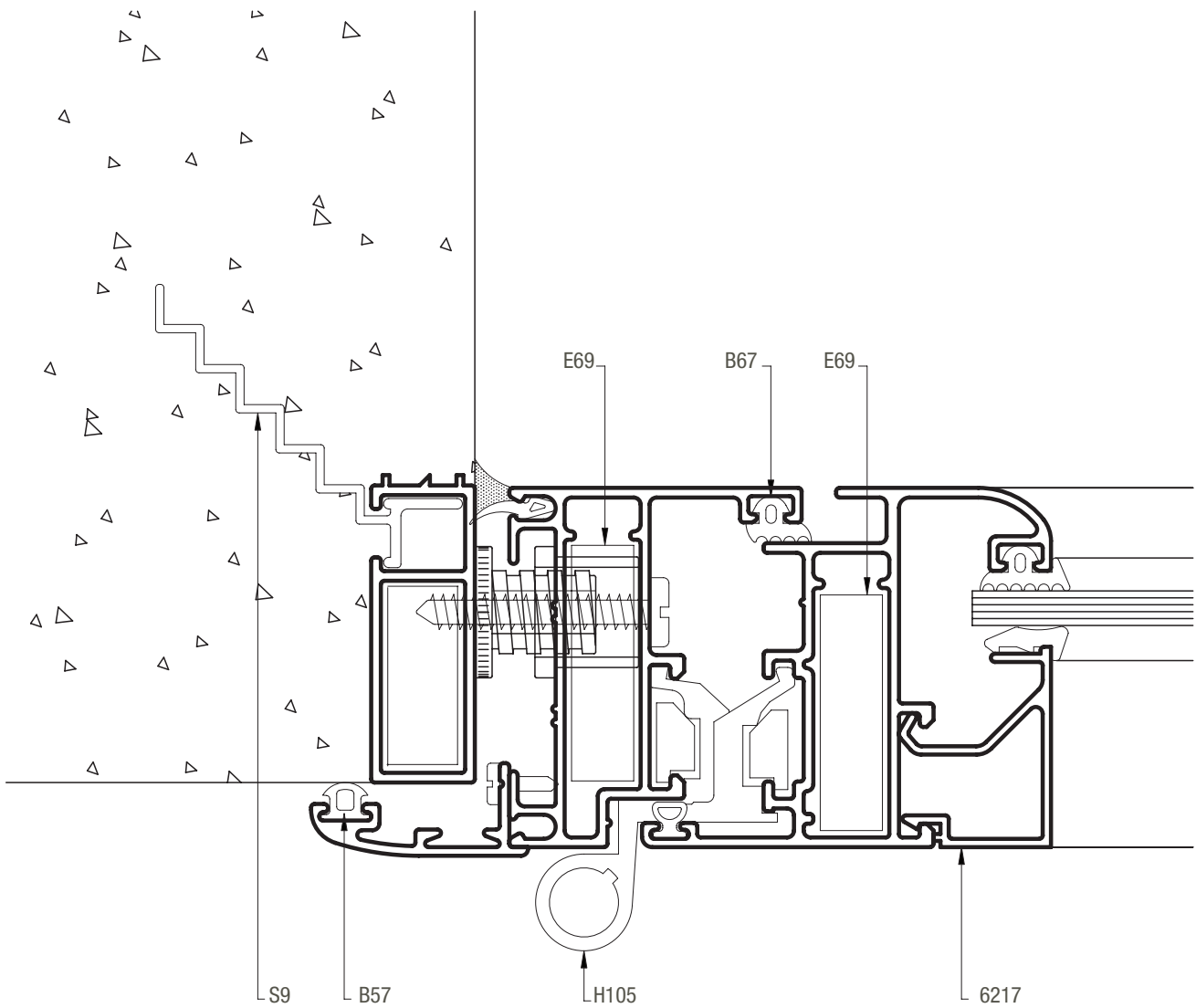

SECCION 5

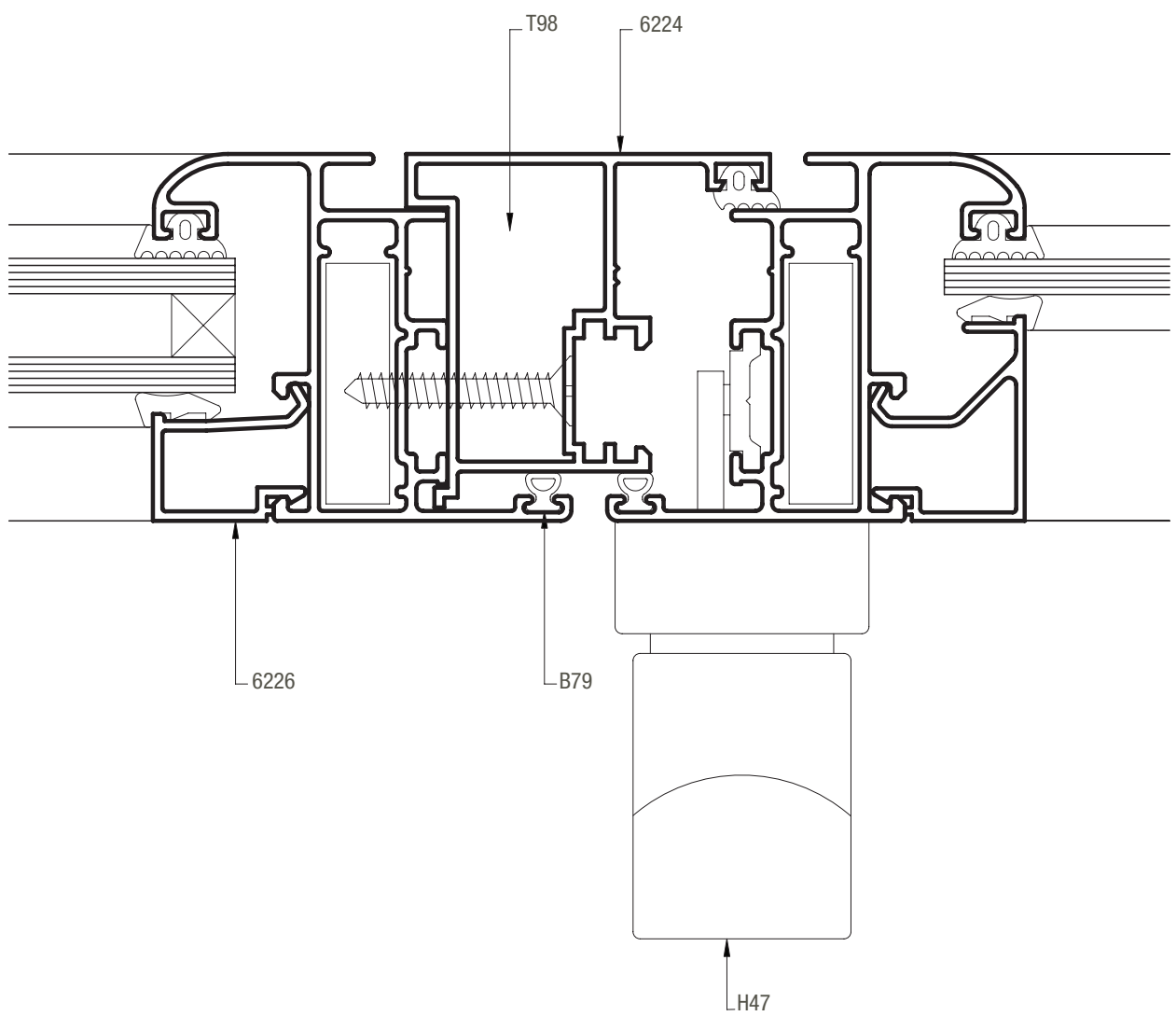

# Módena2 / ventana abrir/oscilobatiente de 1 hoja escalonada

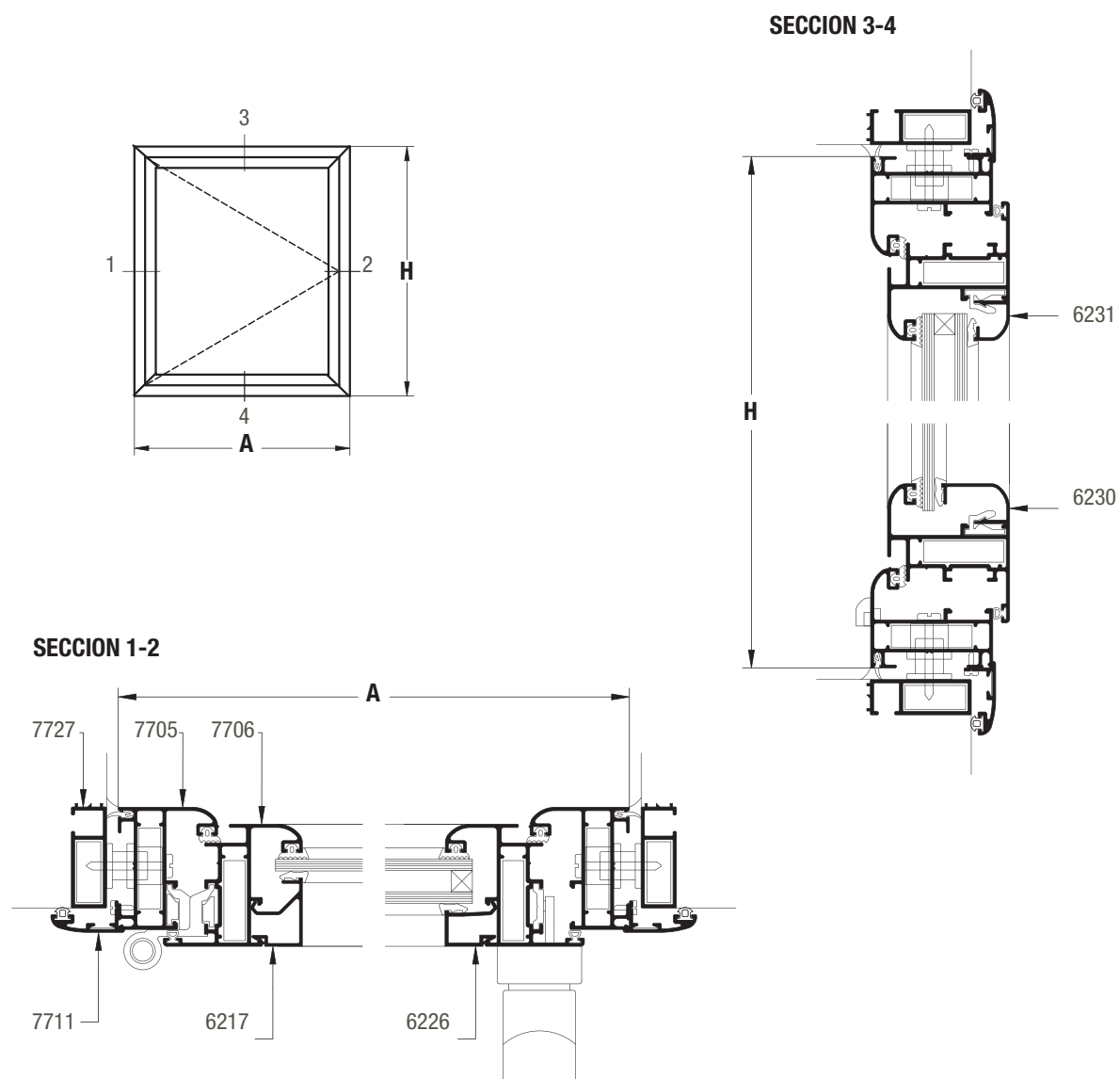

## Dimensión de corte de perfiles

A ancho total del marco H altura total del marco

cantidad de piezas	perfil	descripción	medida mm	corte
2	7727	Jambas premarco	H+40	45-45
2	7727	Umbral y dintel premarco	A+40	45-45
2	7711	Jambas tapa premarco	H+58	45-45
2	7711	Umbral y dintel tapa premarco	A+58	45-45
2	7705	Jamba de marco	H	45-45
2	7705	Umbral y dintel de marco	A	45-45
2	7706	Jambas de hoja	H-38	45-45
2	7706	Zócalo y cabezal de hoja	A-38	45-45

# Módena2 / ventana abrir/oscilobatiente de 2 hojas escalonada

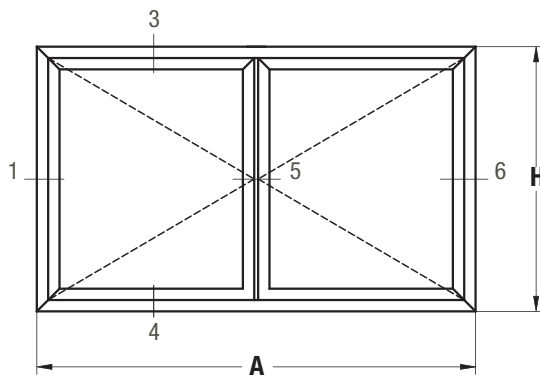

SECCION 3-4

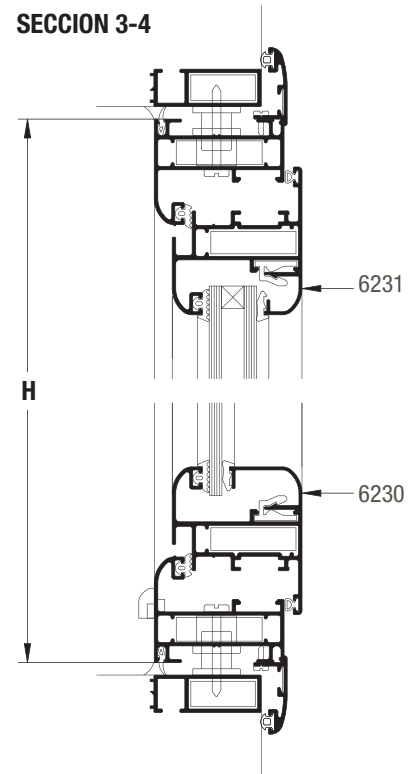

SECCION 1-5-6

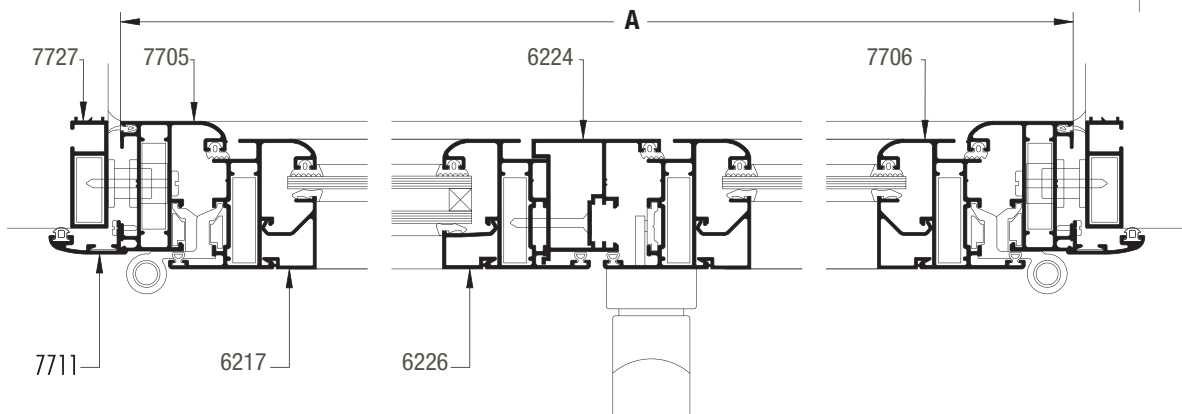

## Dimensión de corte de perfiles

A ancho total del marco H altura total del marco

cantidad de piezas	perfil	descripción	medida mm	corte
2	7727	Jambas premarco	H+40	45-45
2	7727	Umbral y dintel premarco	A+40	45-45
2	7711	Jambas tapa premarco	H+58	45-45
2	7711	Umbral y dintel tapa premarco	A+58	45-45
2	7705	Jamba de marco	H	45-45
2	7705	Umbral y dintel de marco	A	45-45
1	6224	Encuentro central 2 hojas	H-95	90-90
4	7706	Jambas de hoja	H-38	45-45
4	7706	Zócalo y cabezal de hoja	(A/2)-22	45-45

# Módena2 / ventana abrir/oscilobatiente de 1 y 2 hojas escalonada

## SECCION 1

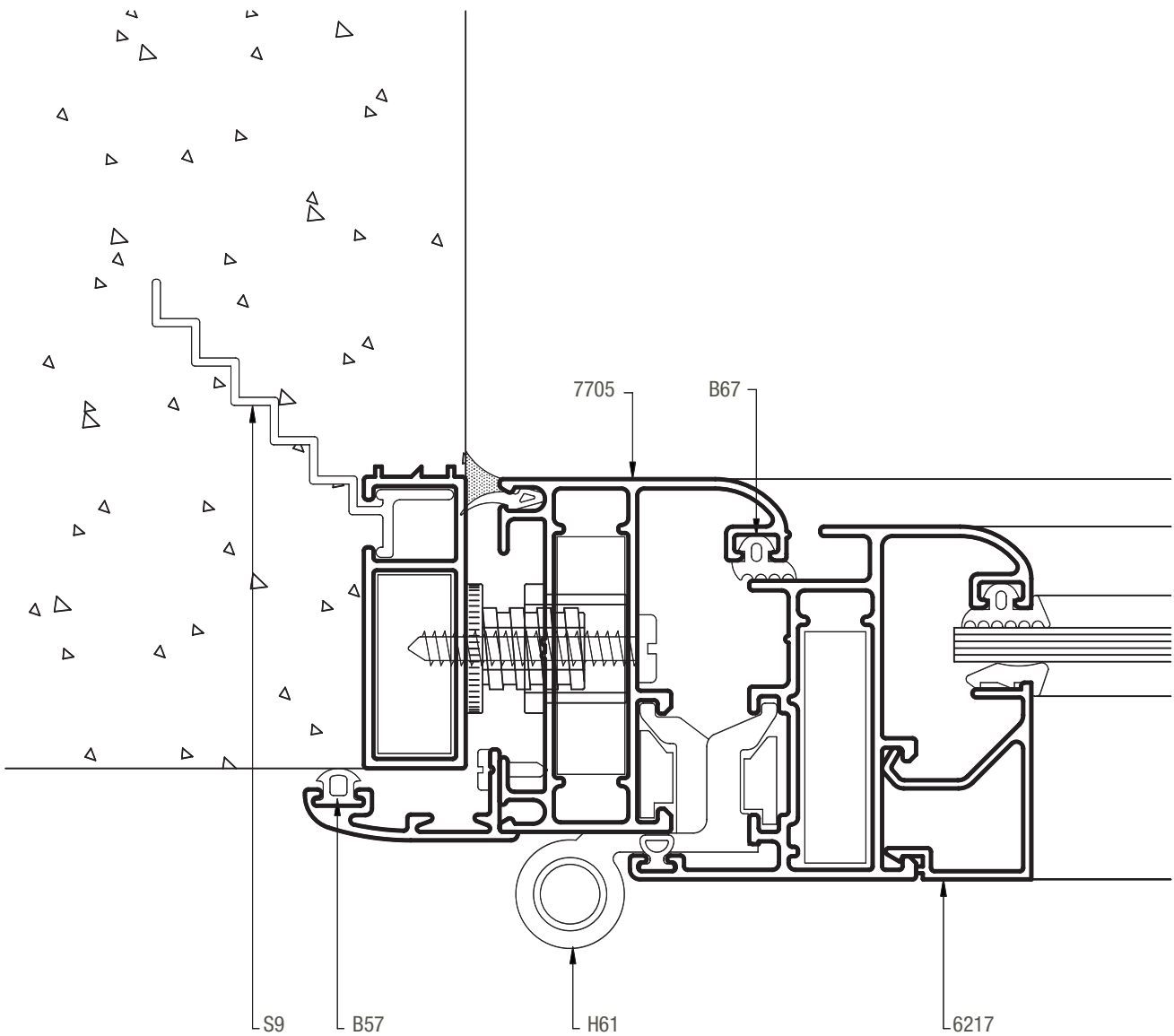

# Módena2 / ventana abrir/oscilobatiente de 1 y 2 hojas escalonada

## SECCION 3

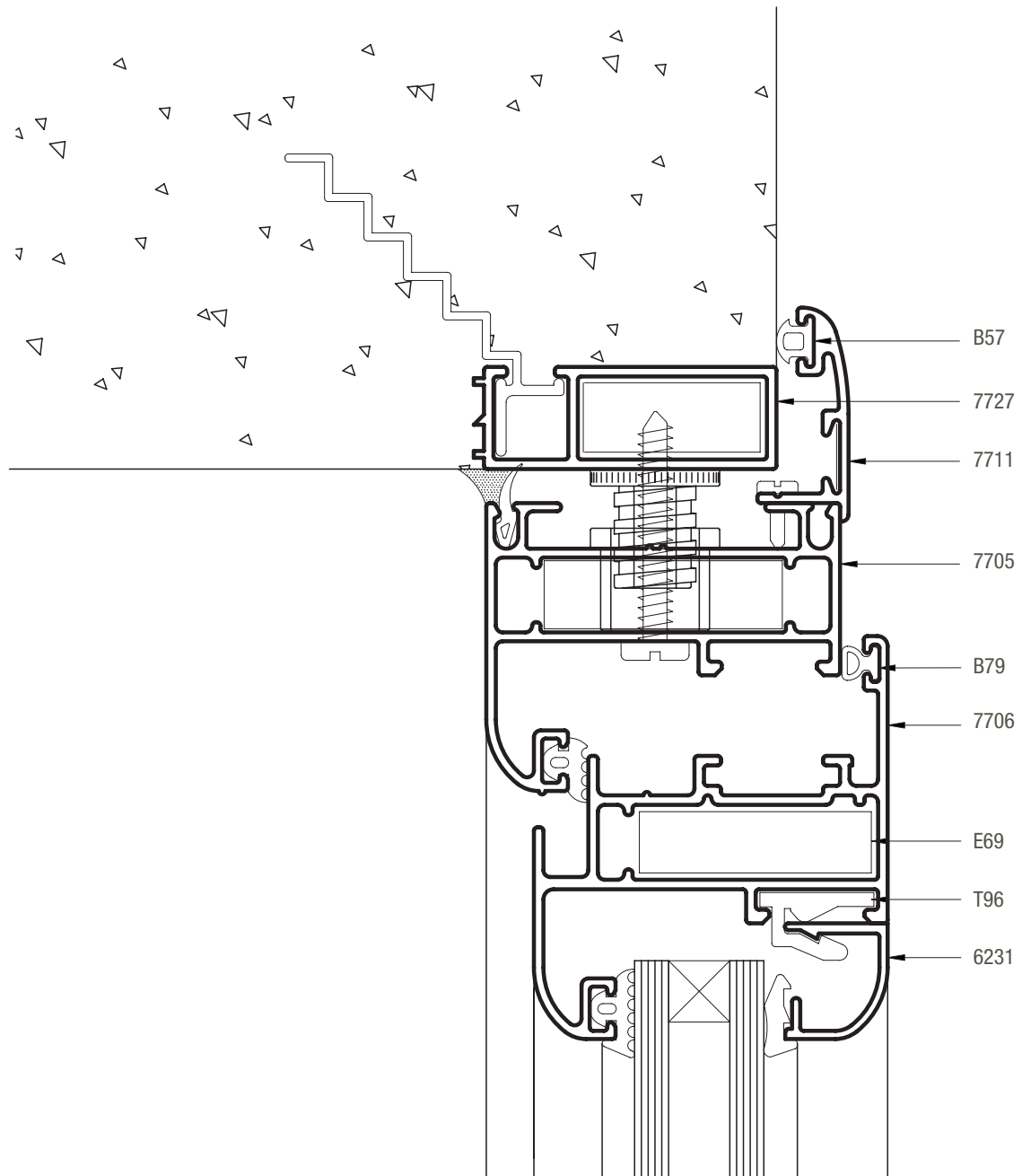

# Módena2 / ventana abrir/oscilobatiente de 1 hoja coplanar con cámara compensadora

## SECCION 3-4

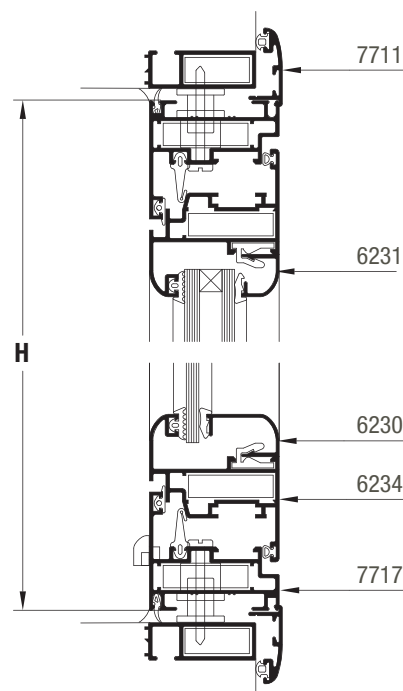
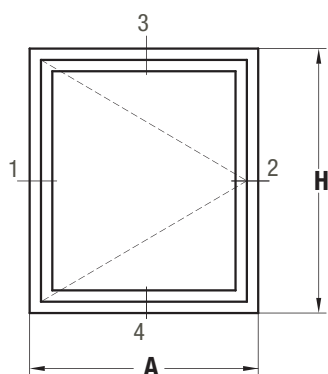

## SECCION 1-2

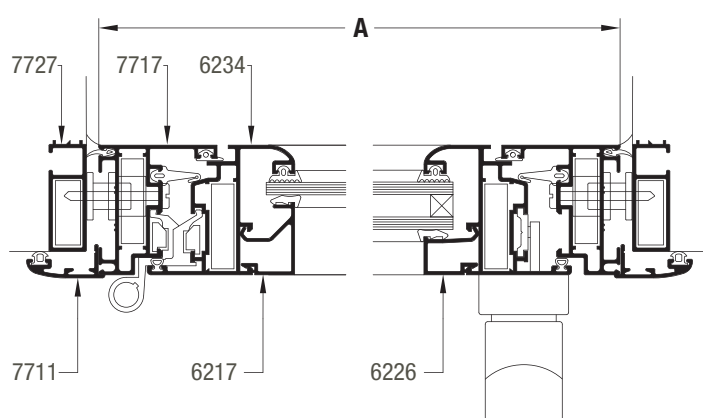

### Dimensión de corte de perfiles

A ancho total del marco H altura total del marco

cantidad de piezas	perfil	descripción	medida mm	corte
2	7727	Jambas premarco	H+40	45-45
2	7727	Umbral y dintel premarco	A+40	45-45
2	7711	Jambas tapa premarco	H+58	45-45
2	7711	Umbral y dintel tapa premarco	A+58	45-45
2	7717	Jamba de marco	H	45-45
2	7717	Umbral y dintel de marco	A	45-45
2	6234	Jambas de hoja	H-39	45-45
2	6234	Zócalo y cabezal de hoja	A-39	45-45

# Módena2 / ventana abrir/oscilobatiente de 2 hojas coplanar con cámara compensadora

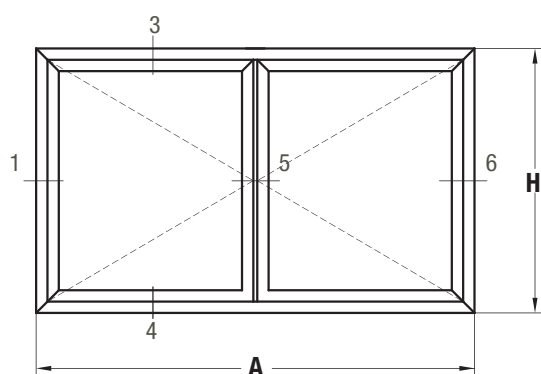

SECCION 3-4

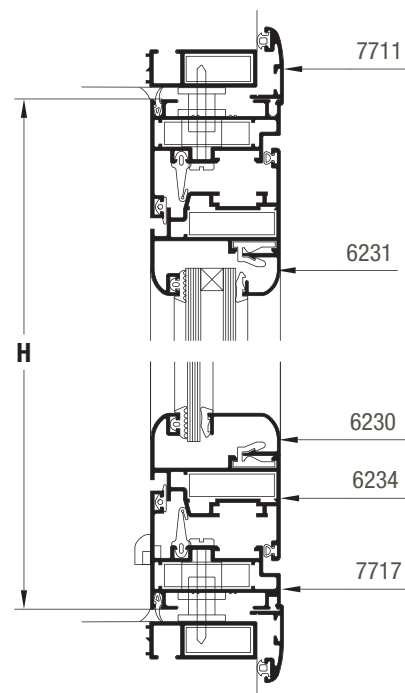

SECCION 1-5-6

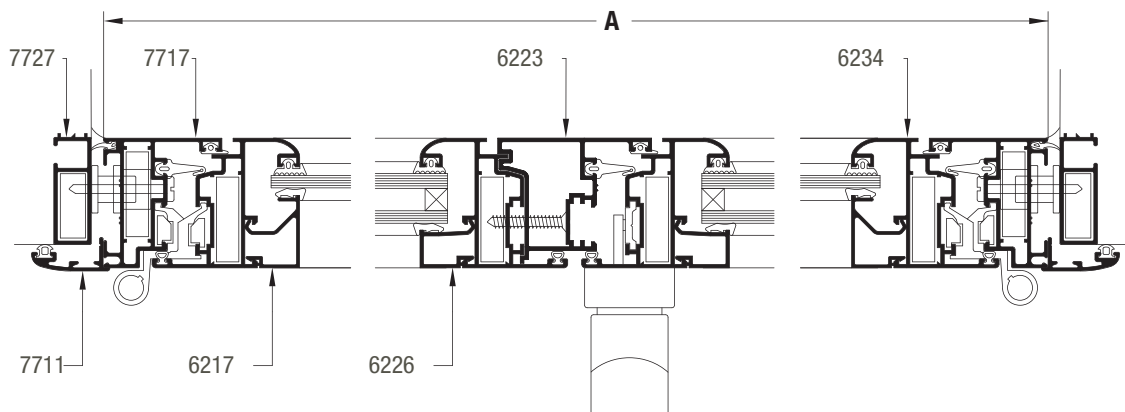

## Dimensión de corte de perfiles

A ancho total del marco H altura total del marco

cantidad de piezas	perfil	descripción	medida mm	corte
2	7727	Jambas premarco	H+40	45-45
2	7727	Umbral y dintel premarco	A+40	45-45
2	7711	Jambas tapa premarco	H+58	45-45
2	7711	Umbral y dintel tapa premarco	A+58	45-45
2	7717	Jamba de marco	H	45-45
2	7717	Umbral y dintel de marco	A	45-45
1	6223	Encuentro central 2 hojas	H-104	90-90
2	6234	Jambas de hoja	H-39	45-45
2	6234	Zócalo y cabezal de hoja	(A/2)-23	45-45

**Módena2** / ventana abrir/oscilobatiente de 1 y 2 hojas  
con cámara compensadora

**SECCION 1**

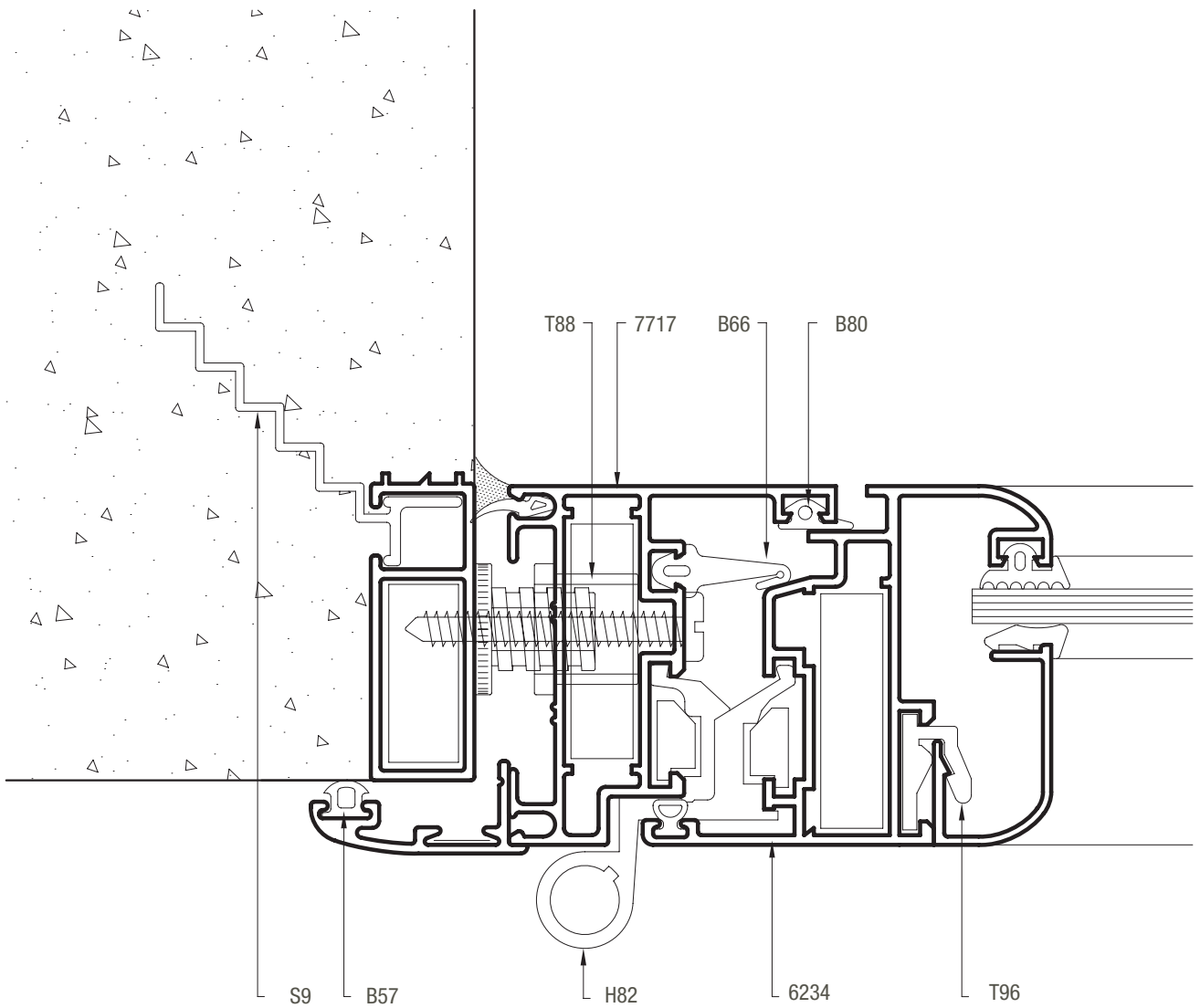



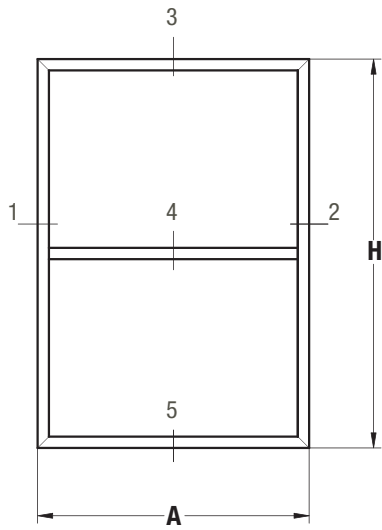

SECCION 3-4-5

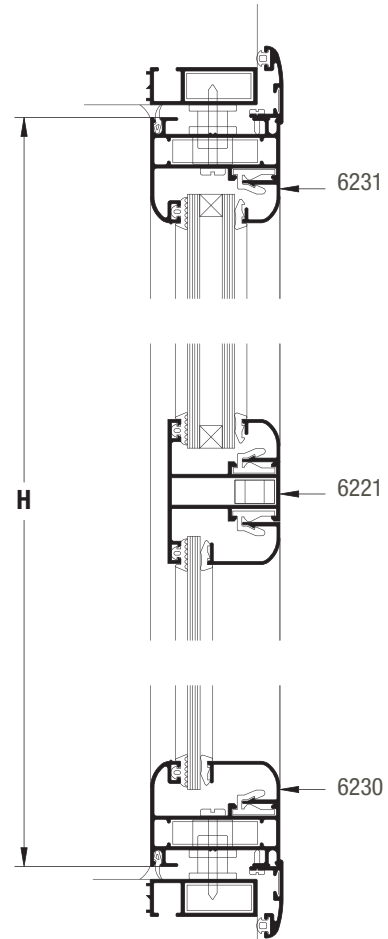

SECCION 1-2

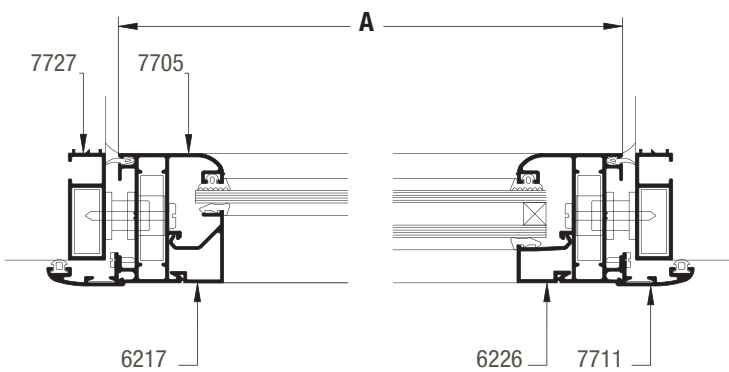

Dimensión de corte de perfiles

A ancho total del marco H altura total del marco

cantidad de piezas	perfil	descripción	medida mm	corte
2	7727	Jambas premarco	H+40	45-45
2	7727	Umbral y dintel premarco	A+40	45-45
2	7711	Jambas tapa premarco	H+58	45-45
2	7711	Umbral y dintel premarco	A+58	45-45
2	7705	Jamba de marco	H	45-45
2	7705	Umbral y dintel de marco	A	45-45
1	6221	Travesaño horizontal	A-51	90-90

# Módena2 / paño fijo

## SECCION 3-4

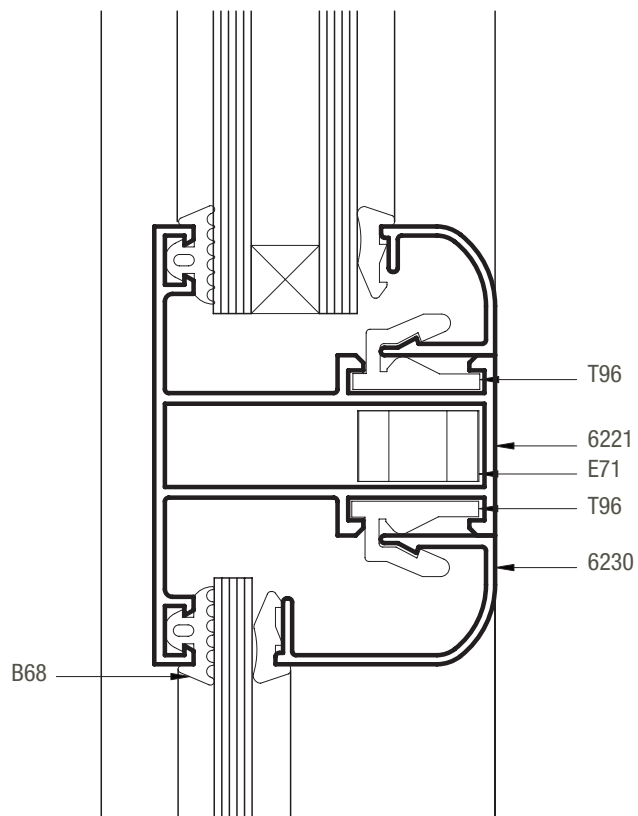
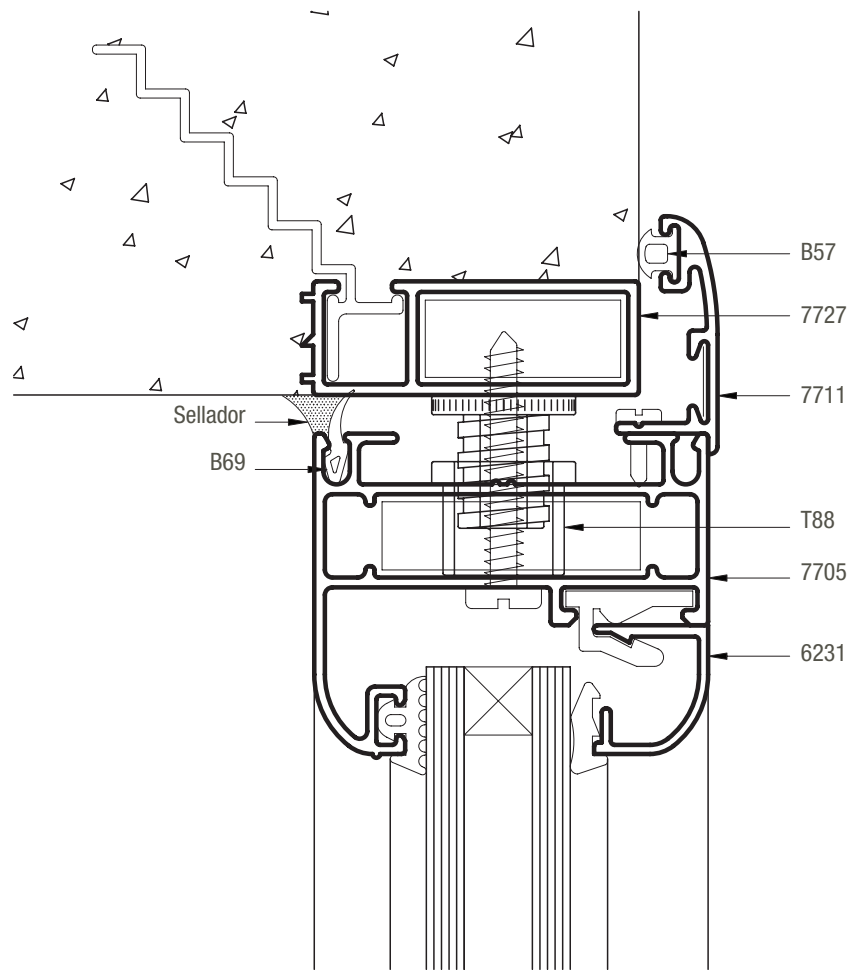

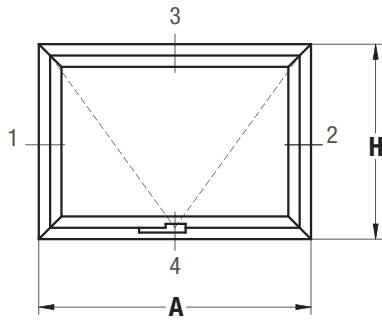

SECCION 3-4

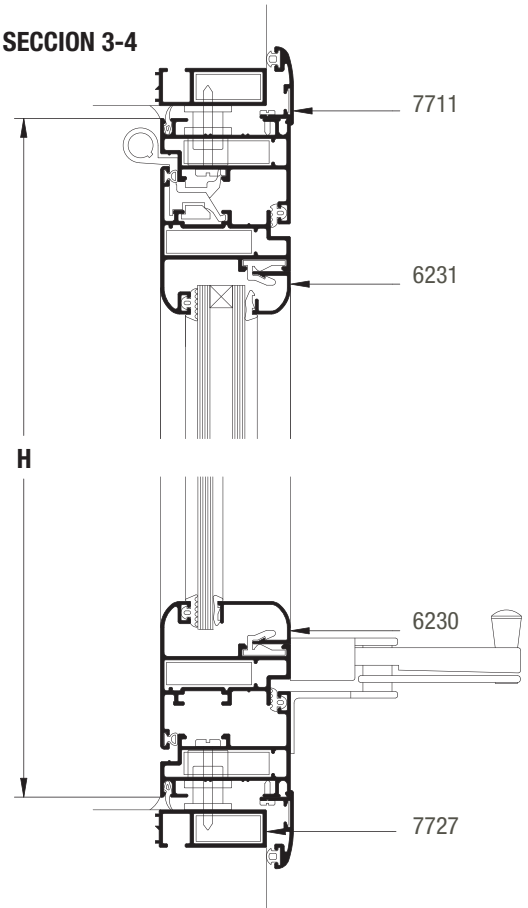

SECCION 1-2

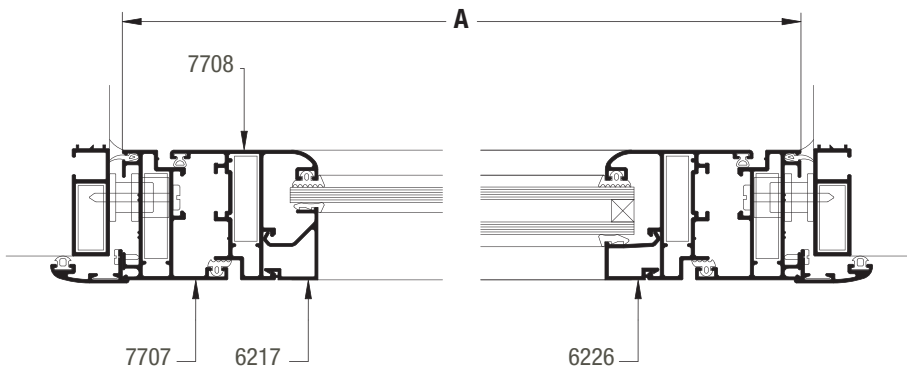

**Dimensión de corte de perfiles**

A ancho total del marco H altura total del marco

cantidad de piezas	perfil	descripción	medida mm	corte
2	7727	Jambas premarco	H+40	45-45
2	7727	Umbral y dintel premarco	A+40	45-45
2	7711	Jambas tapa premarco	H+58	45-45
2	7711	Umbral y dintel tapa premarco	A+58	45-45
2	7707	Jamba de marco	H	45-45
2	7707	Umbral y dintel de marco	A	45-45
2	7708	Jamba de hoja	H-38	45-45
2	7708	Dintel y umbral hoja	A-38	45-45

SECCION 1

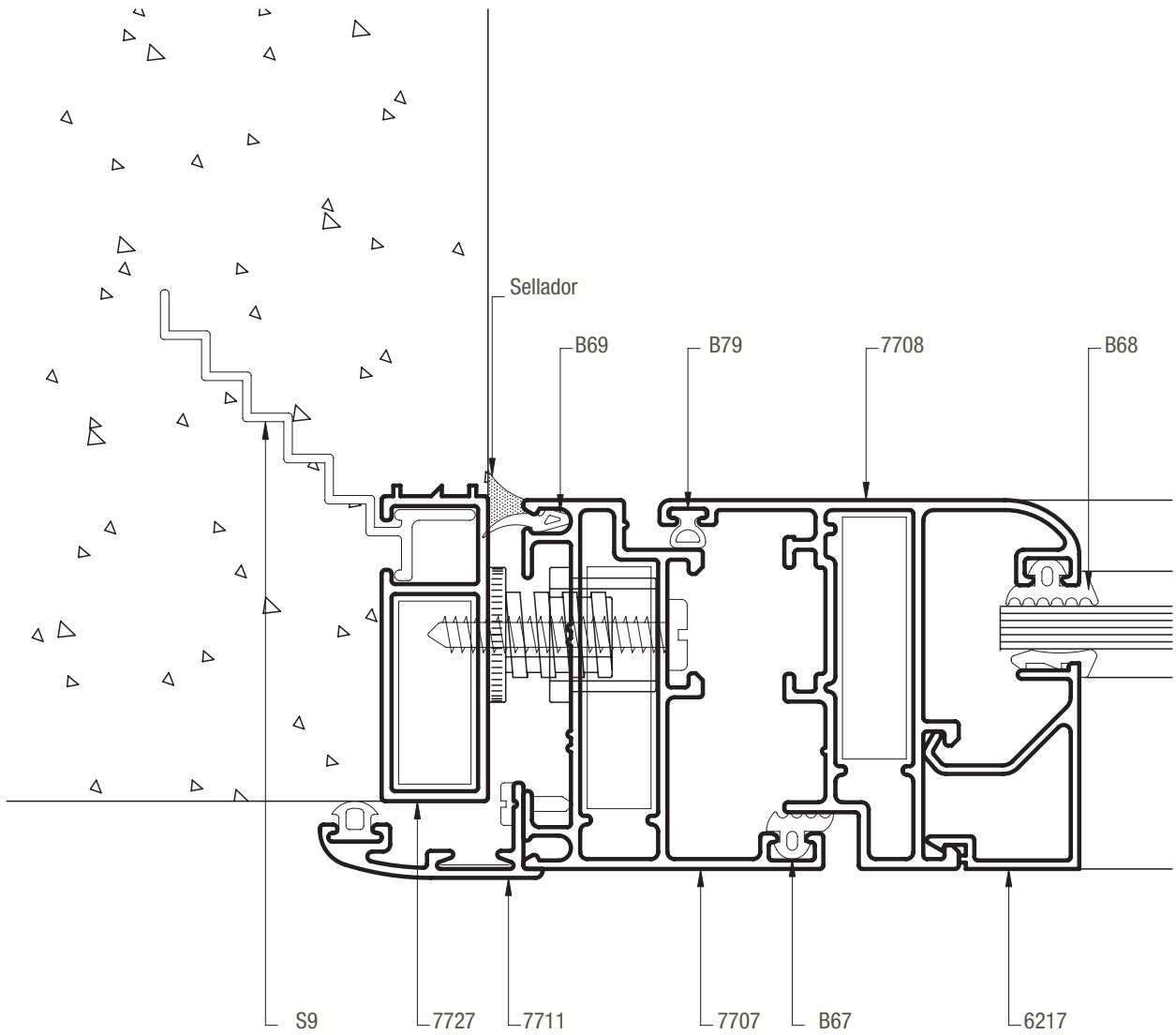

SECCION 3

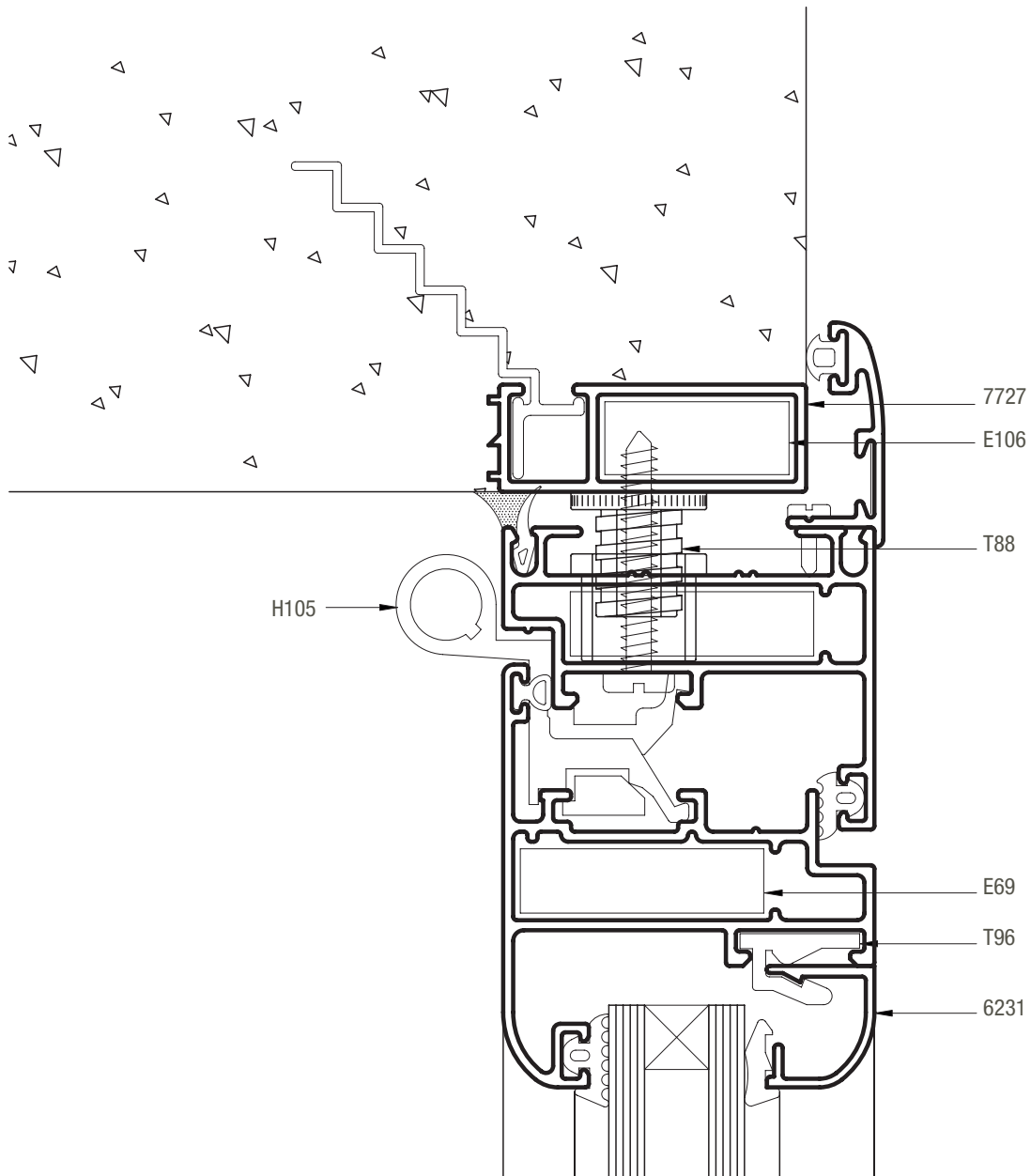

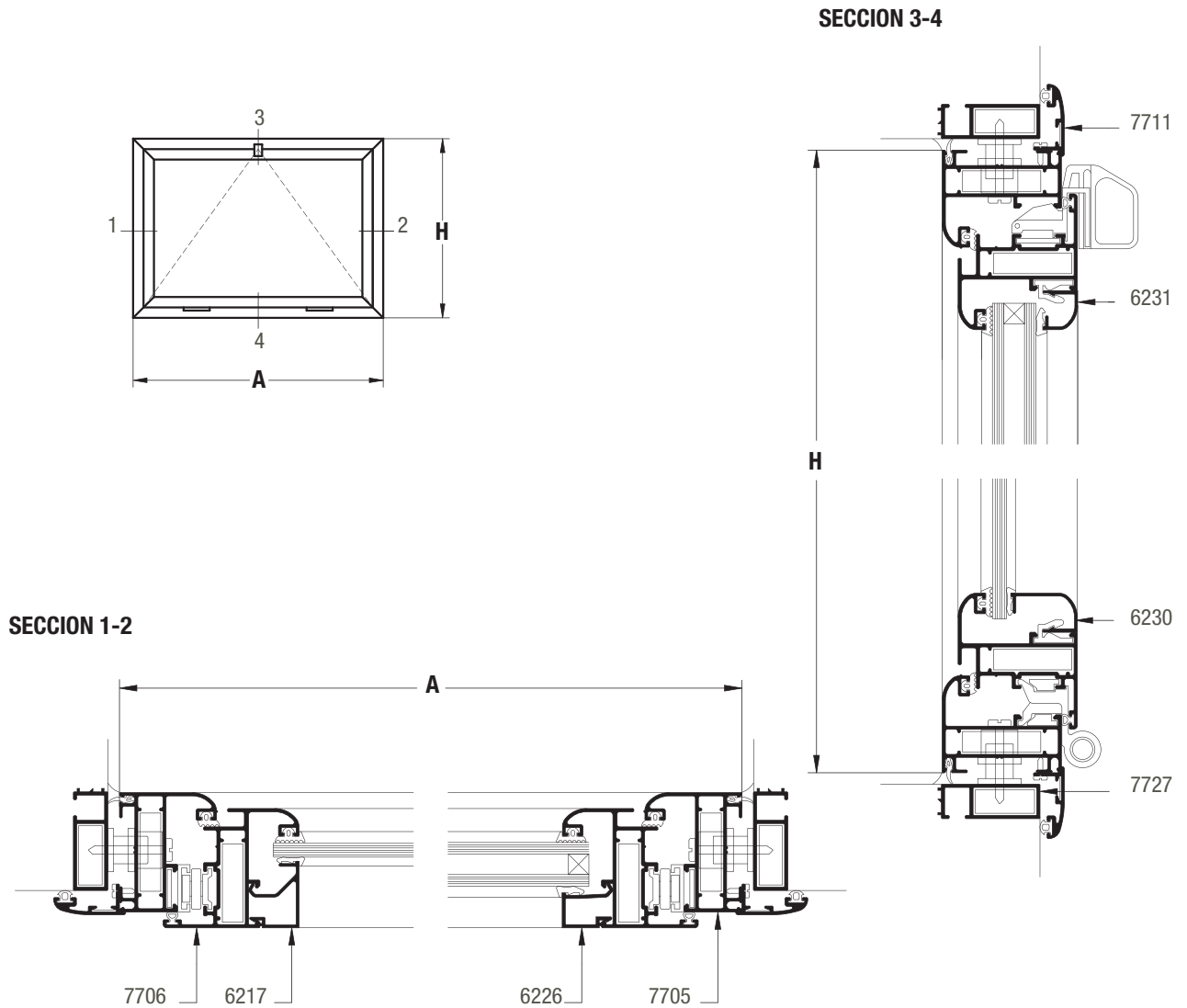

**Dimensión de corte de perfiles**

A ancho total del marco H altura total del marco

cantidad de piezas	perfil	descripción	medida mm	corte
2	7727	Jambas premarco	H+40	45-45
2	7727	Umbral y dintel premarco	A+40	45-45
2	7711	Jambas tapa premarco	H+58	45-45
2	7711	Umbral y dintel tapa premarco	A+58	45-45
2	7705	Jamba de marco	H	45-45
2	7705	Umbral y dintel de marco	A	45-45
2	7706	Jamba de hoja	H-38	45-45
2	7706	Dintel y umbral hoja	A-38	45-45

SECCION 1

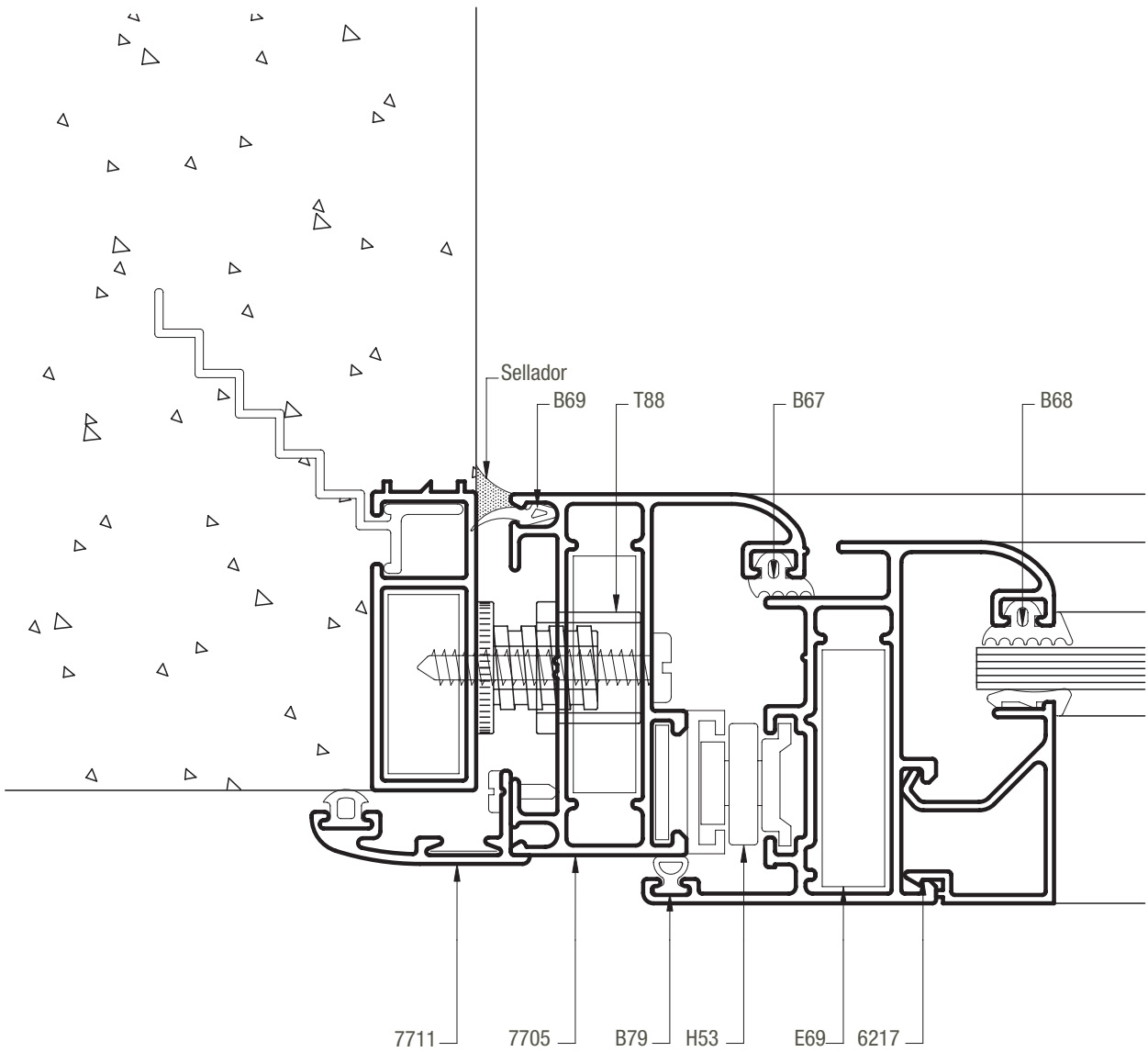

SECCION 4

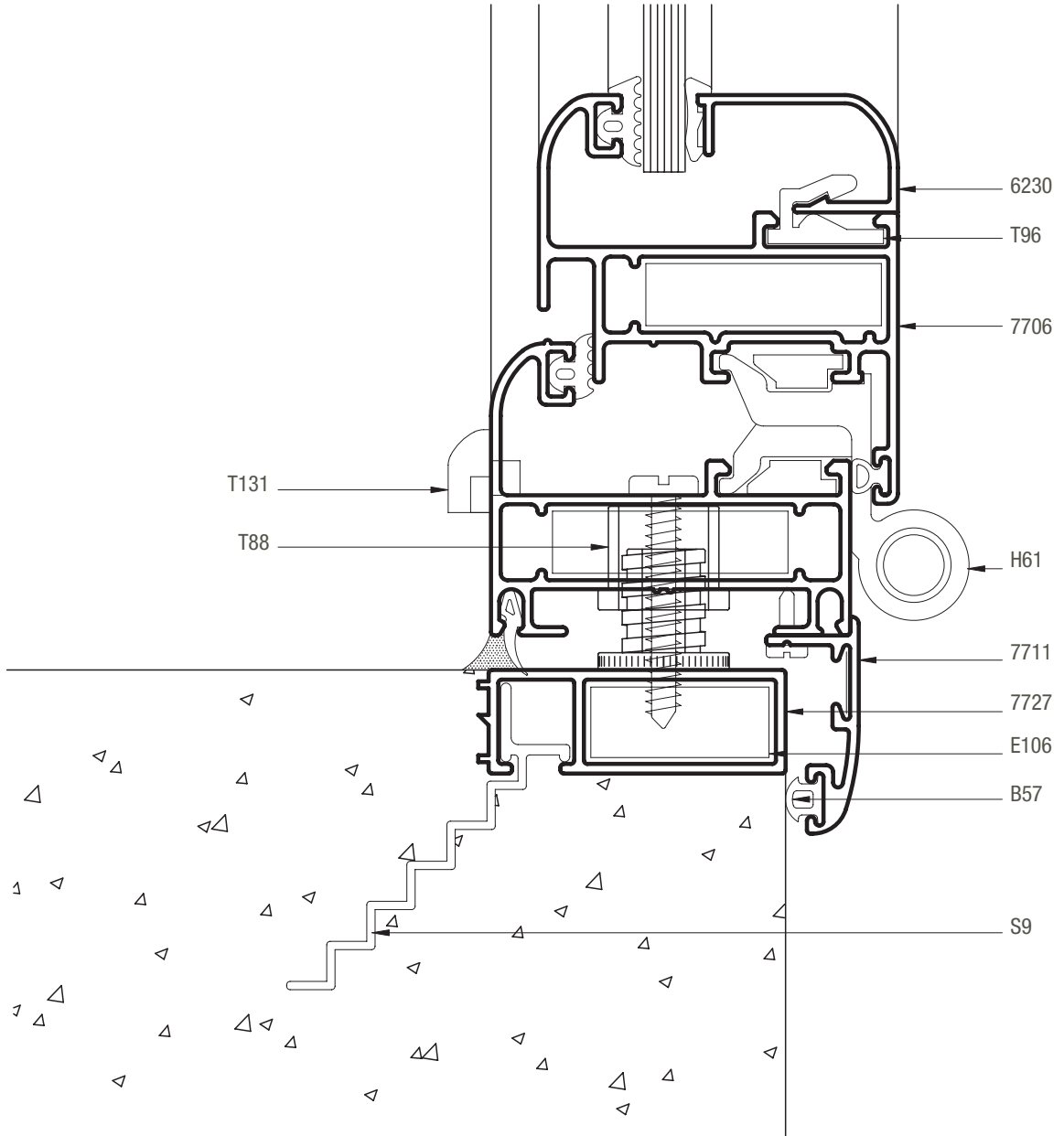

# Módena2 / ventana desplazable

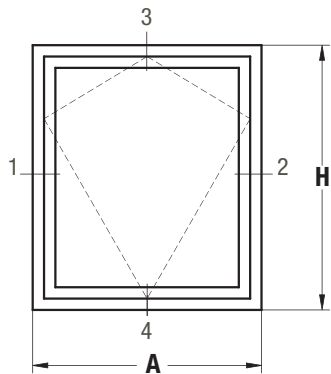

SECCION 3-4

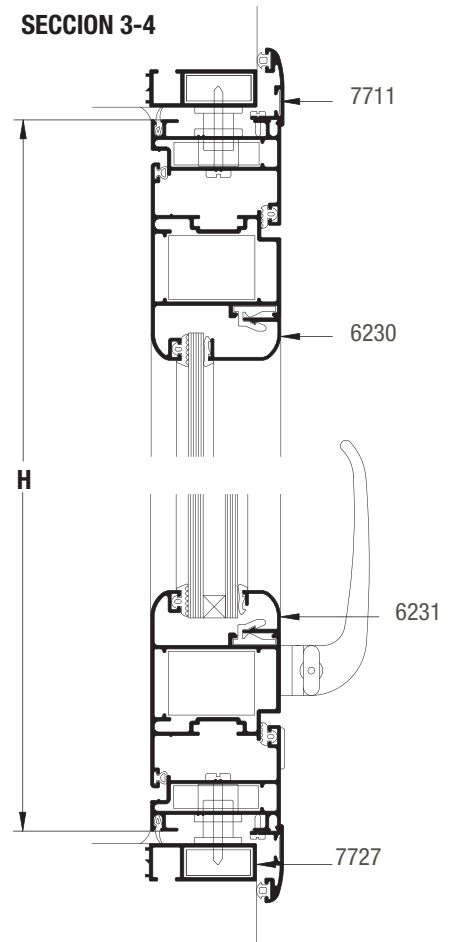

SECCION 1-2

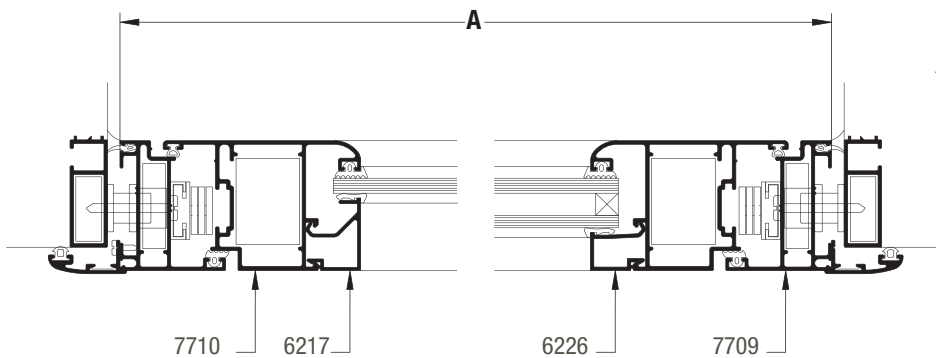

## Dimensión de corte de perfiles

A ancho total del marco H altura total del marco

cantidad de piezas	perfil	descripción	medida mm	corte
2	7727	Jambas premarco	H+40	45-45
2	7727	Umbral y dintel premarco	A+40	45-45
2	7711	Jambas tapa premarco	H+58	45-45
2	7711	Umbral y dintel premarco	A+58	45-45
2	7709	Jamba de marco	H	45-45
2	7709	Umbral y dintel de marco	A	45-45
2	7710	Jamba de hoja	H-35	45-45
2	7710	Umbral y cabezal hoja	A-35	45-45

SECCION 1

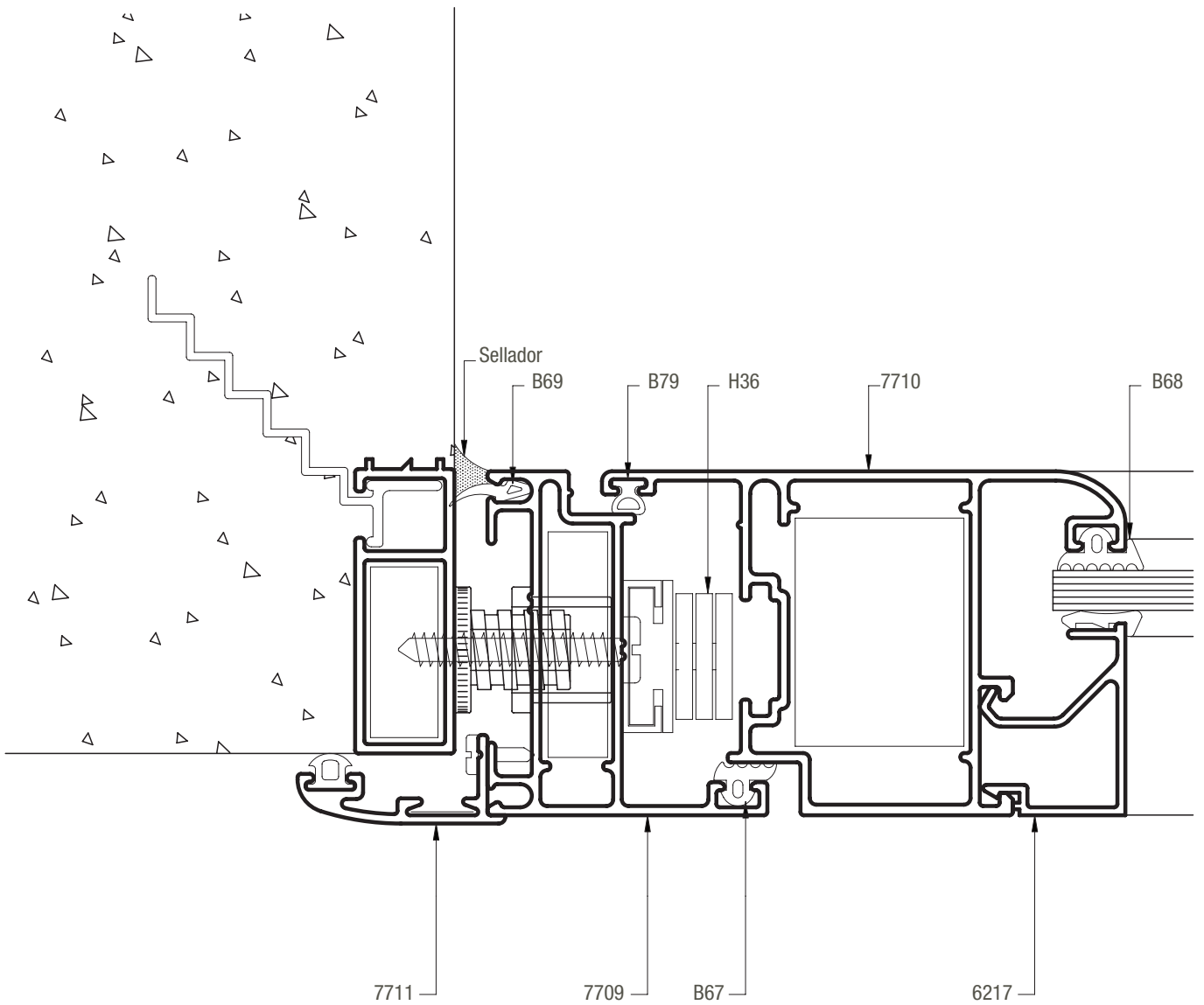

SECCION 4

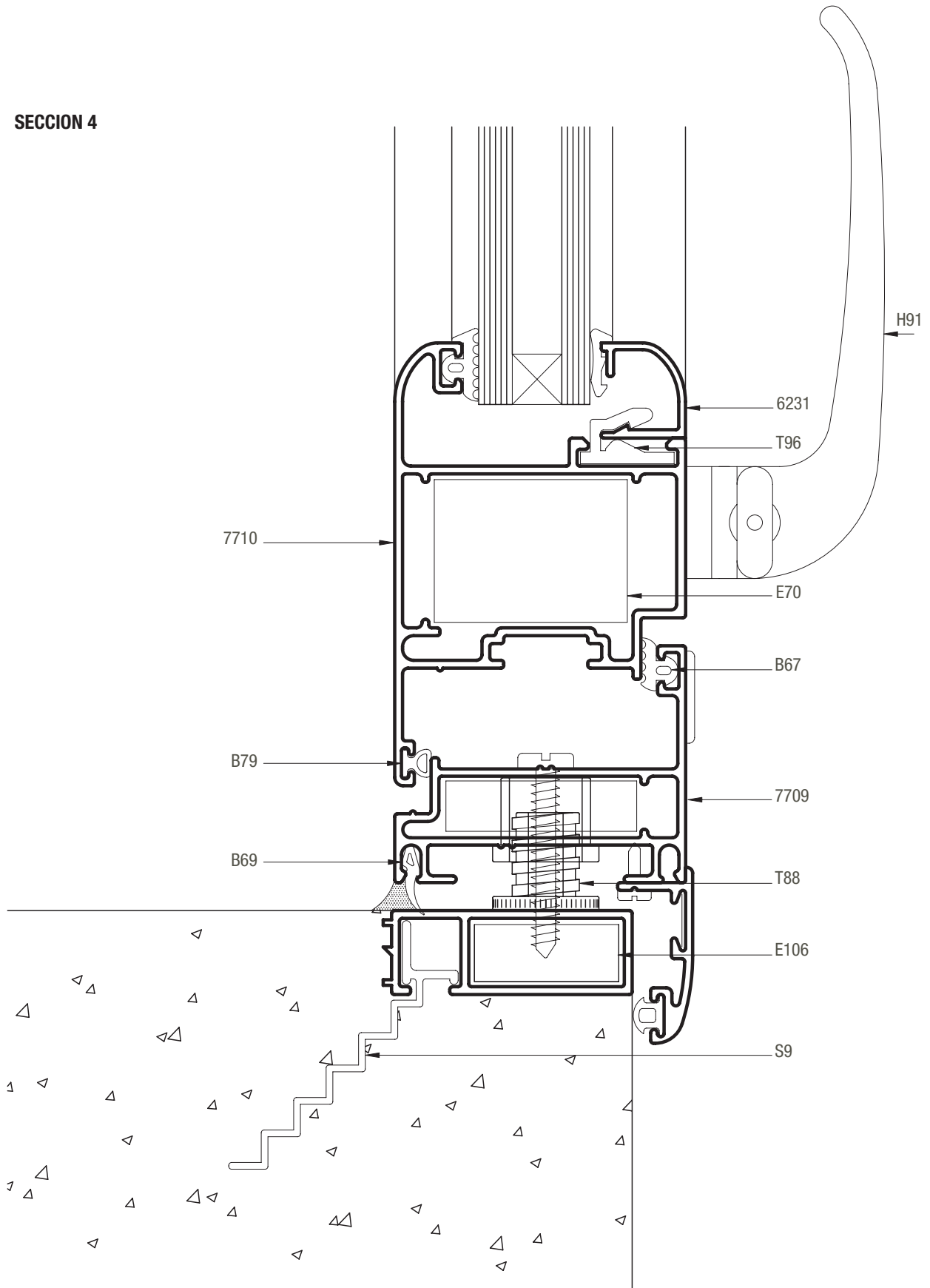

# Módena2 / puerta de rebatir de 1 hoja

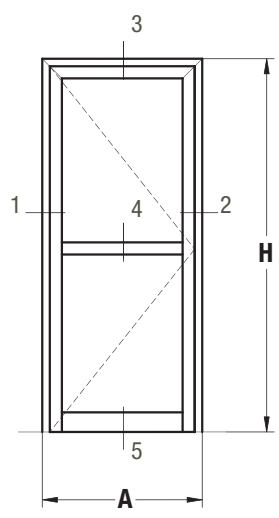

## SECCION 3-4-5

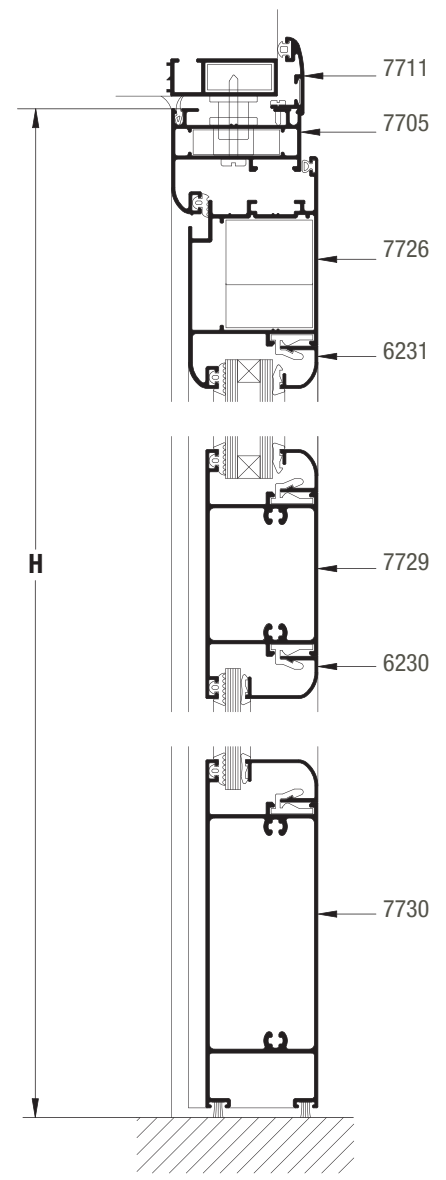

## SECCION 1-2

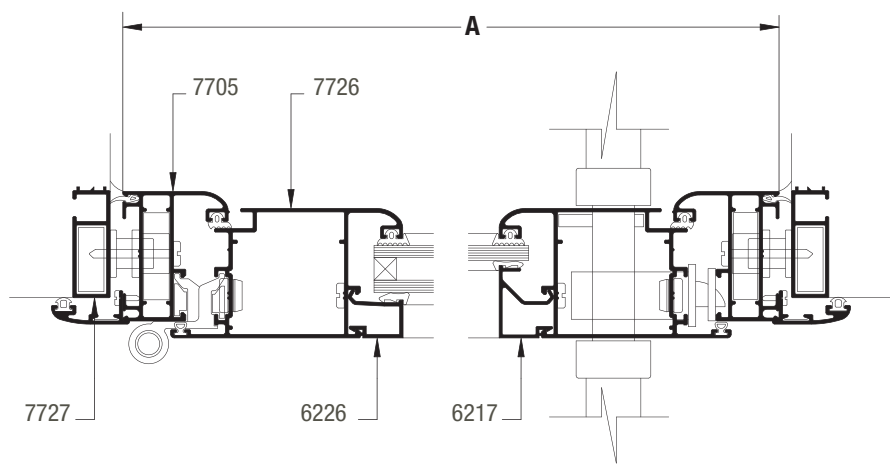

### Dimensión de corte de perfiles A ancho total del marco H altura total del marco

cantidad de piezas	perfil	descripción	medida mm	corte
2	7727	Jambas premarco	H+18	45-90
1	7727	Dintel premarco	A+40	45-45
2	7711	Jambas tapa premarco	H+29	45-90
1	7711	Dintel tapa premarco	A+58	45-45
2	7705	Jamba de marco	H	45-90
1	7705	Dintel de marco	A	45-45
2	7726	Jamba de hoja	H-24	45-90
1	7726	Cabezal de hoja	A-39	45-45
1	7730	Zócalo de hoja	A-191	90-90
1	7729	Travesaño de hoja	A-191	90-90

SECCION 2

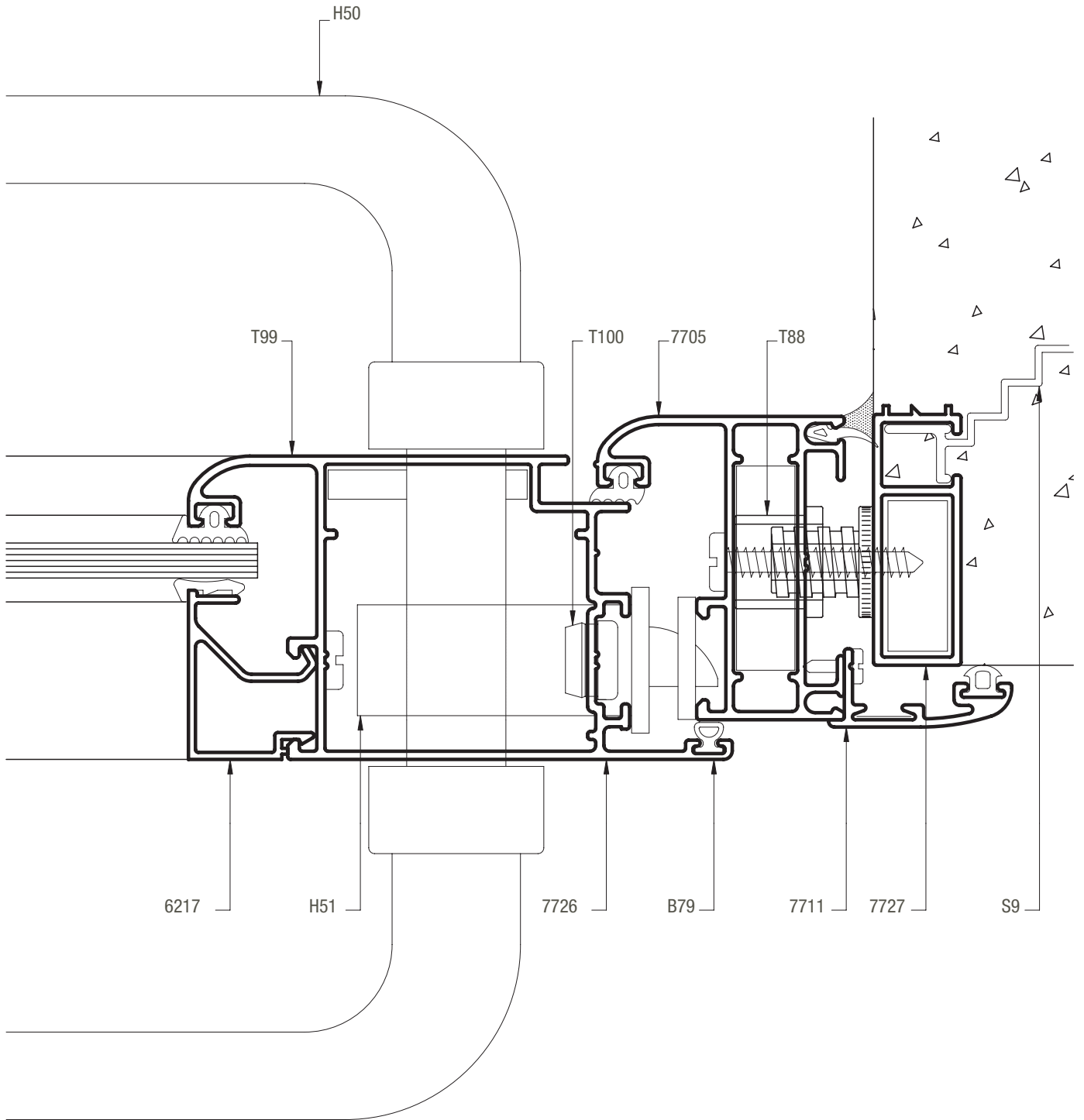

SECCION 3

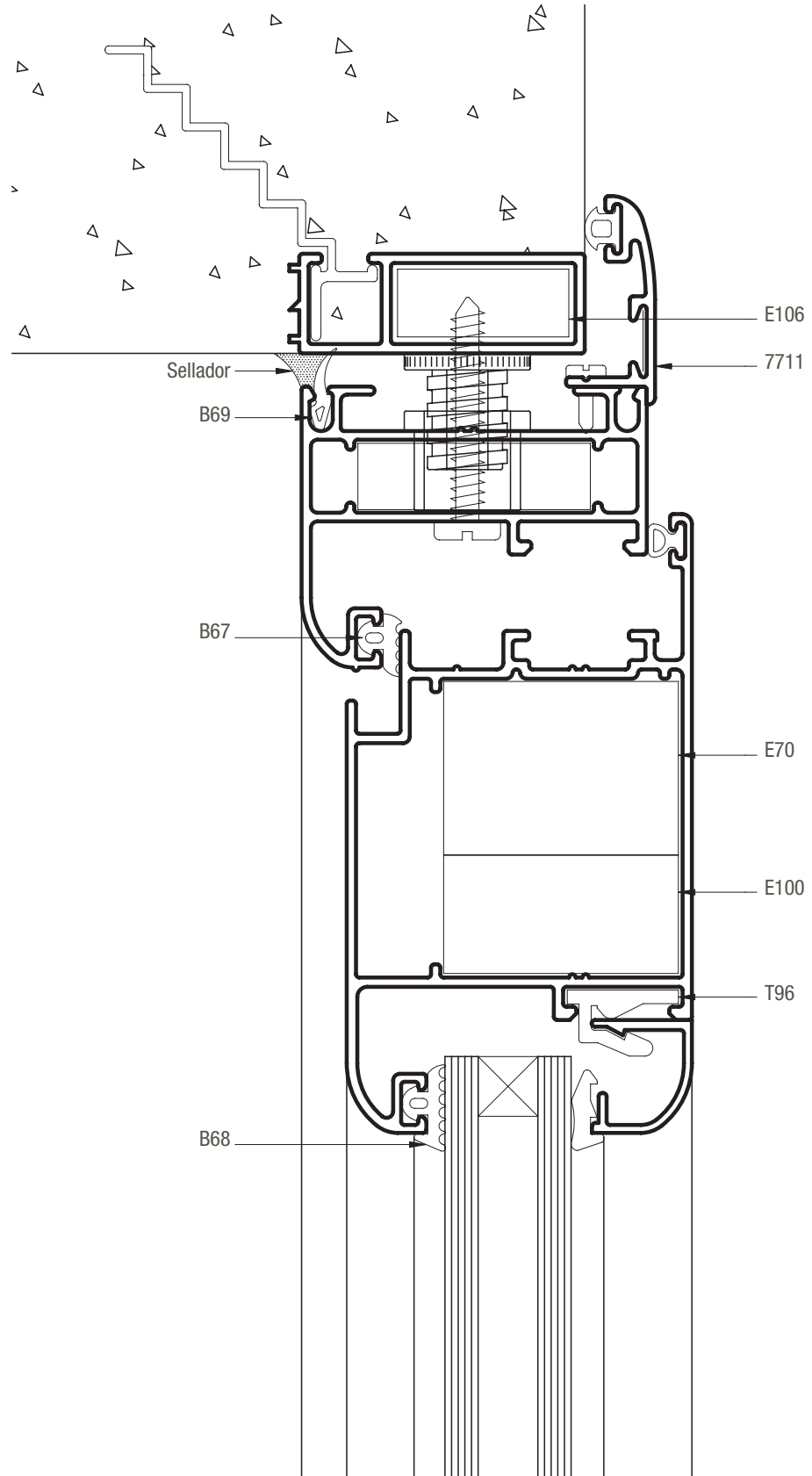

# Módena2 / puerta de rebatir de 2 hojas

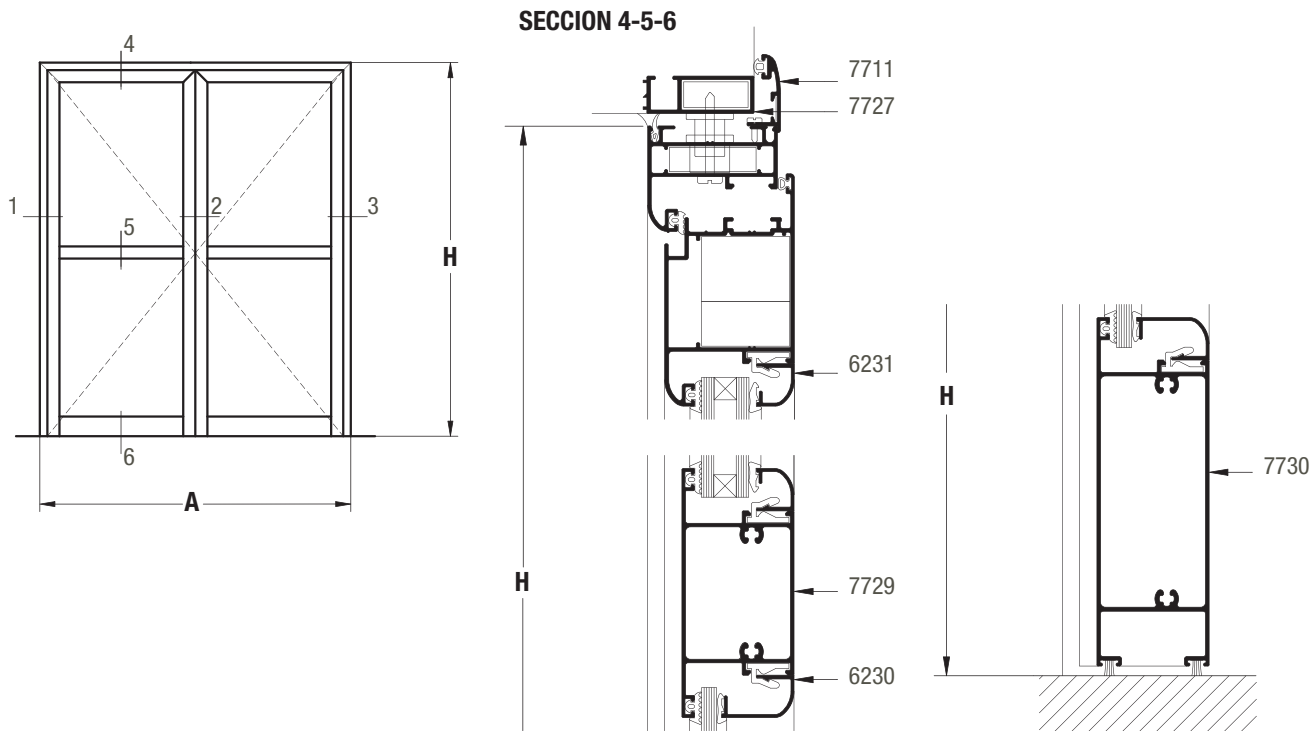

SECCION 1-2-3

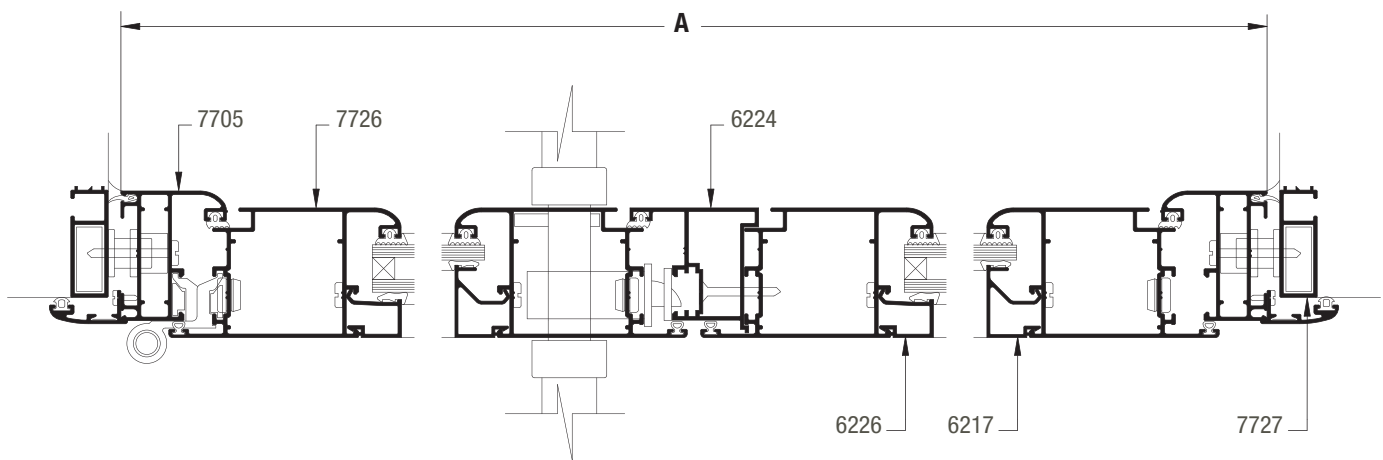

## Dimensión de corte de perfiles

A ancho total del marco H altura total del marco

cantidad de piezas	perfil	descripción	medida mm	corte
2	7727	Jambas premarco	H+18	45-90
1	7727	Dintel premarco	A+40	45-45
2	7711	Jambas tapa premarco	H+29	45-90
1	7711	Dintel tapa premarco	A+58	45-45
2	7705	Jamba de marco	H	45-90
1	7705	Dintel de marco	A	45-45
1	6224	Encuentro central de 2 hojas	H-52	90-90
4	7726	Jamba de hoja	H-24	45-45
2	7726	Cabezal de hoja	(A/2)-22	45-45
2	7730	Zócalo de hoja	(A/2)-174	90-90
2	7729	Travesaño de hoja	(A/2)-174	90-90



# Módena2 / puerta de rebatir de 2 hojas

## SECCION 2

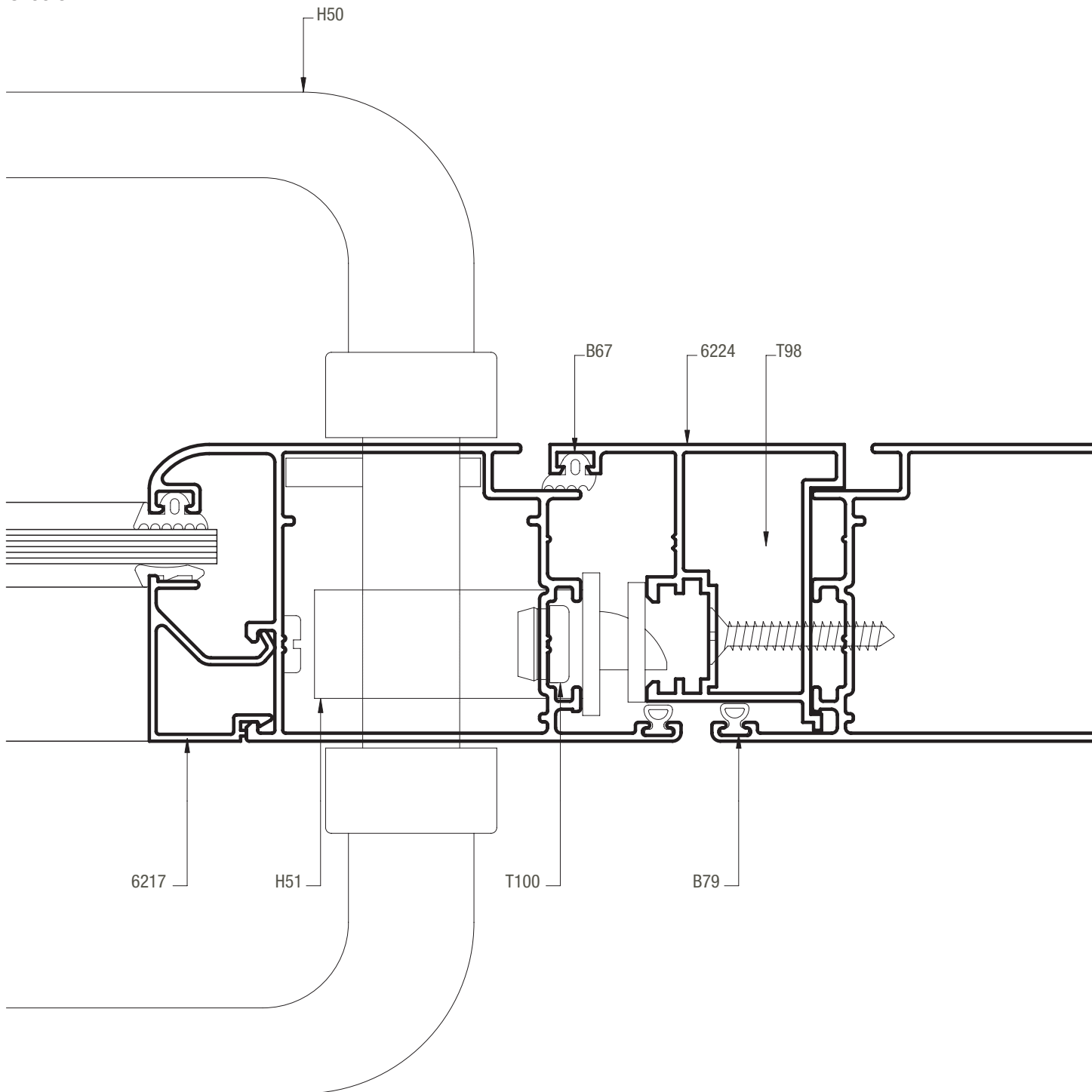

SECCION 6

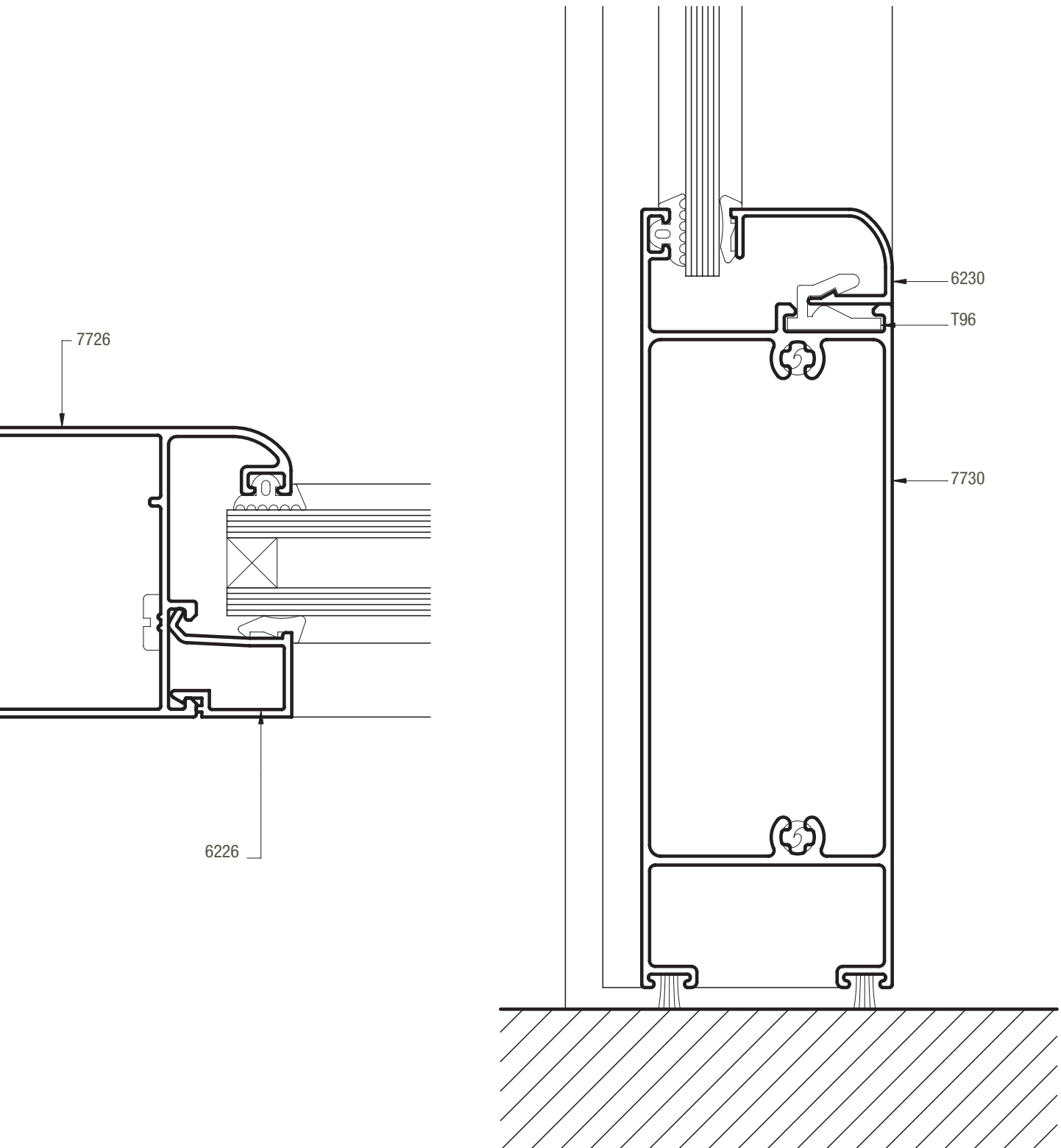

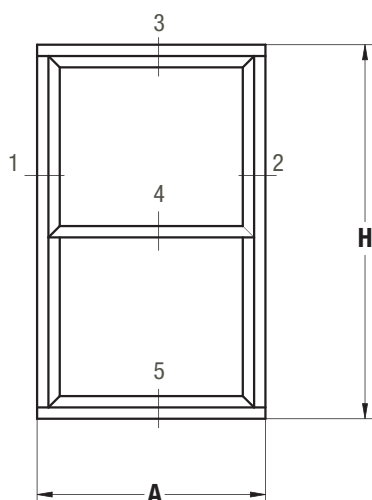

SECCION 1-2

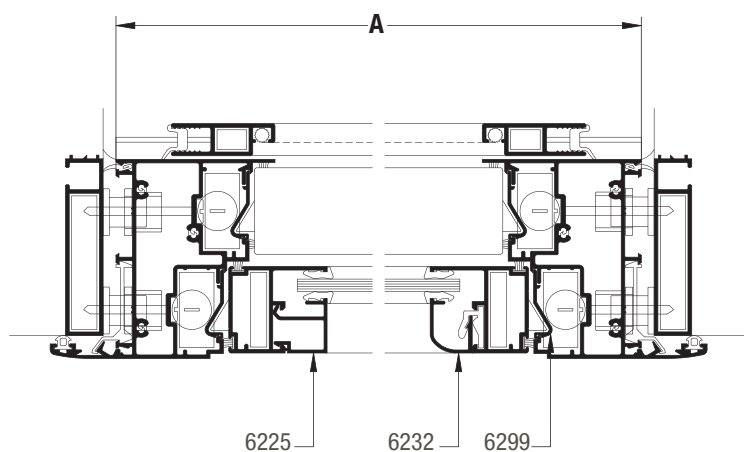

SECCION 3-4-5

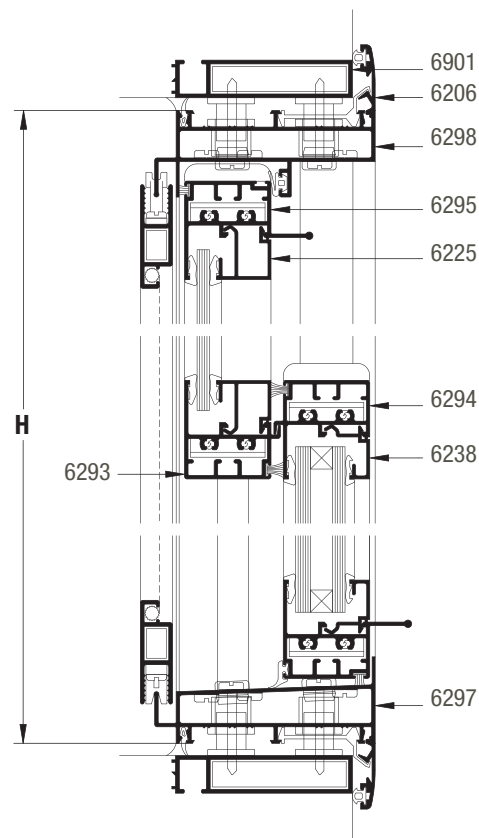

## Dimensión de corte de perfiles

A ancho total del marco H altura total del marco

cantidad de piezas	perfil	descripción	medida mm	corte
2	6206	Jambas tapa premarco	H+53	45-45
2	6206	Umbral y dintel tapa premarco	A+53	45-45
1	6293	Parante central externo	A-111	45-45
1	6294	Parante central interno	A-91	45-45
1	6295	Cabezal de hoja	A-111	45-45
1	6295	Zócalo de hoja	A-91	45-45
2	6296	Jambas de marco	H-42	90-90
1	6297	Umbral de marco	A	90-90
1	6298	Dintel de marco	A	90-90
4	6900	Parante lateral de hoja	(H/2)-8	45-45
2	6901	Jamba premarco guillotina	H+36	45-45
2	6901	Umbral y dintel premarco guillotina	A+36	45-45

SECCION 1

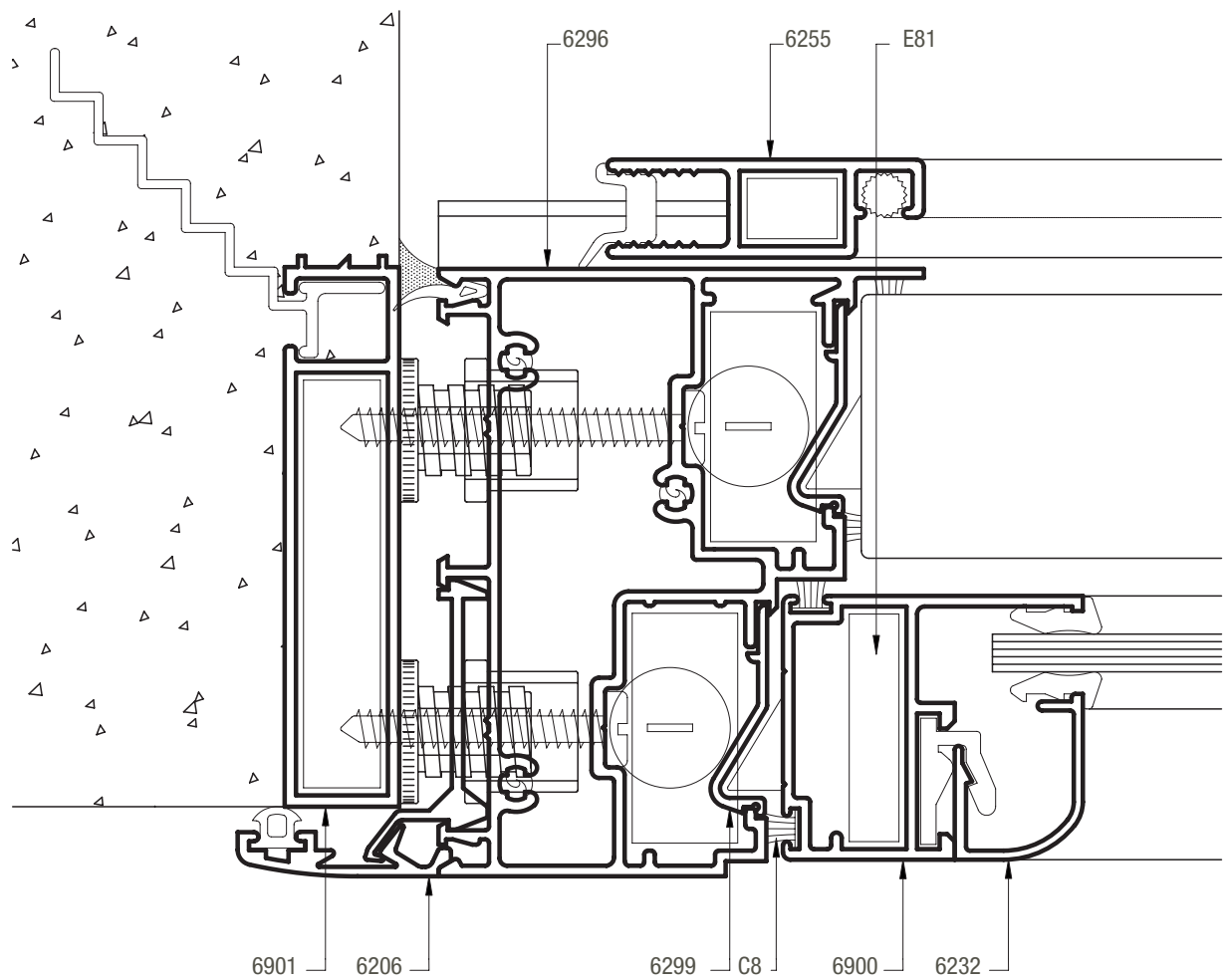

# Módena2 / ventana guillotina

SECCION 3-4

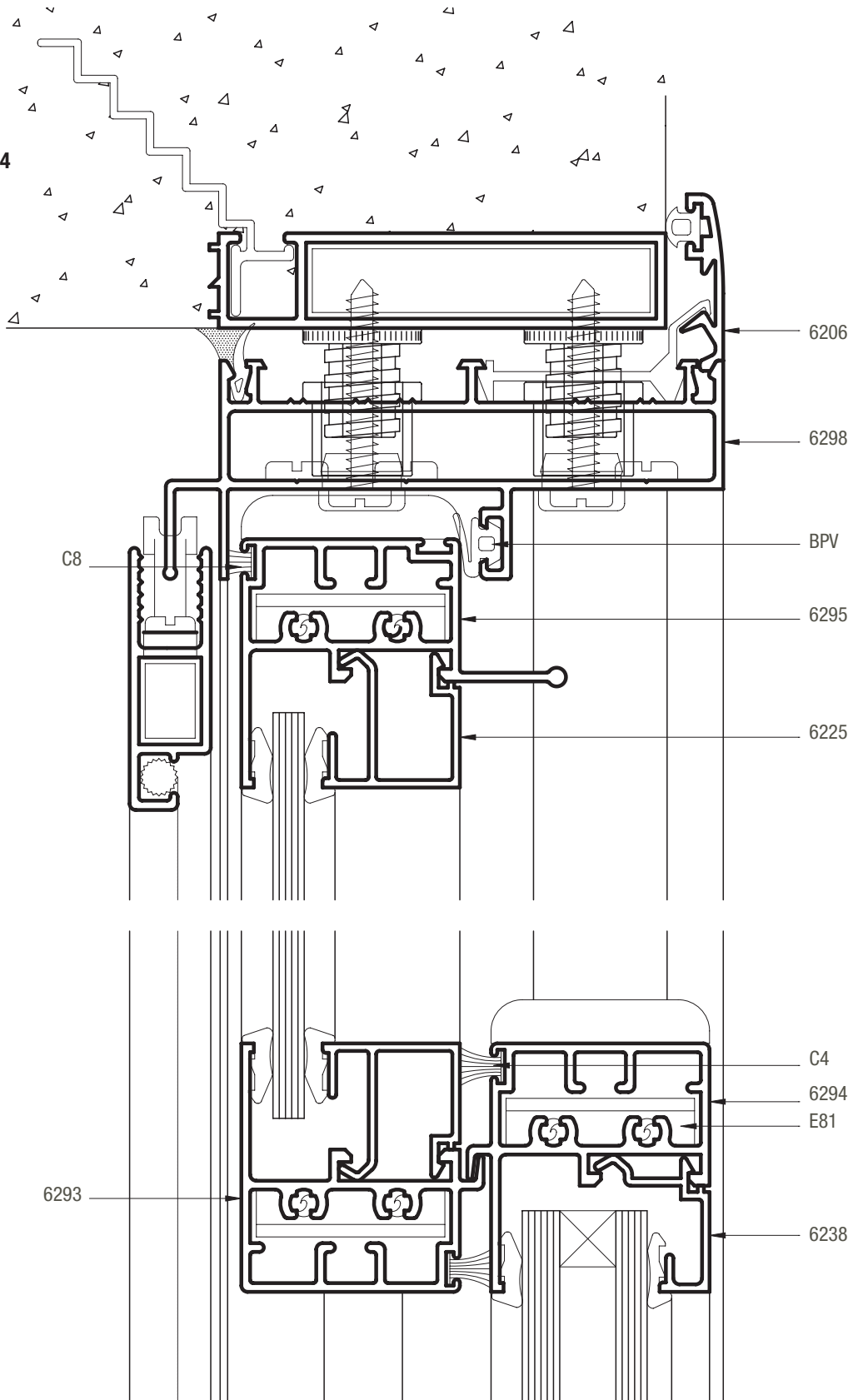

SECCION 5

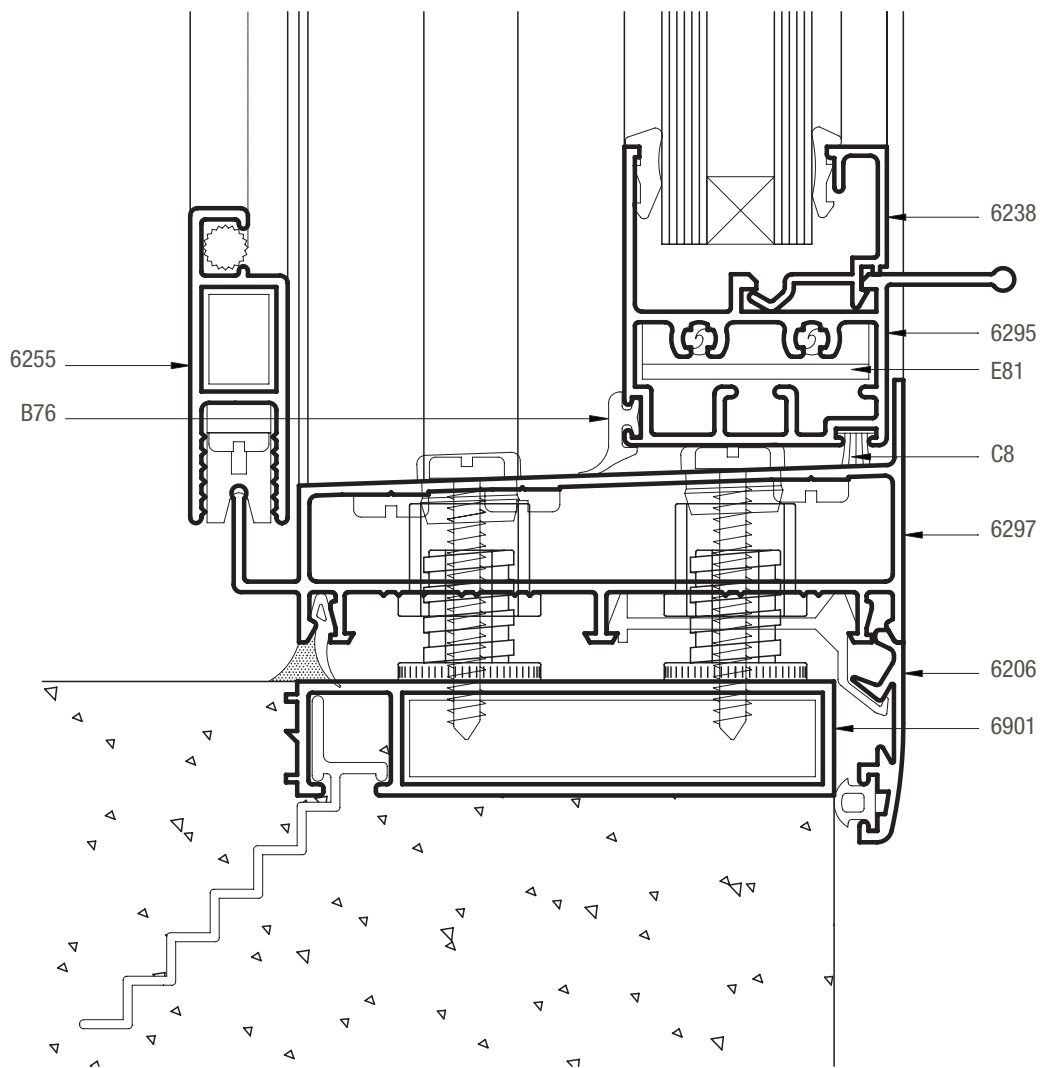

**Perfil de acople simple**

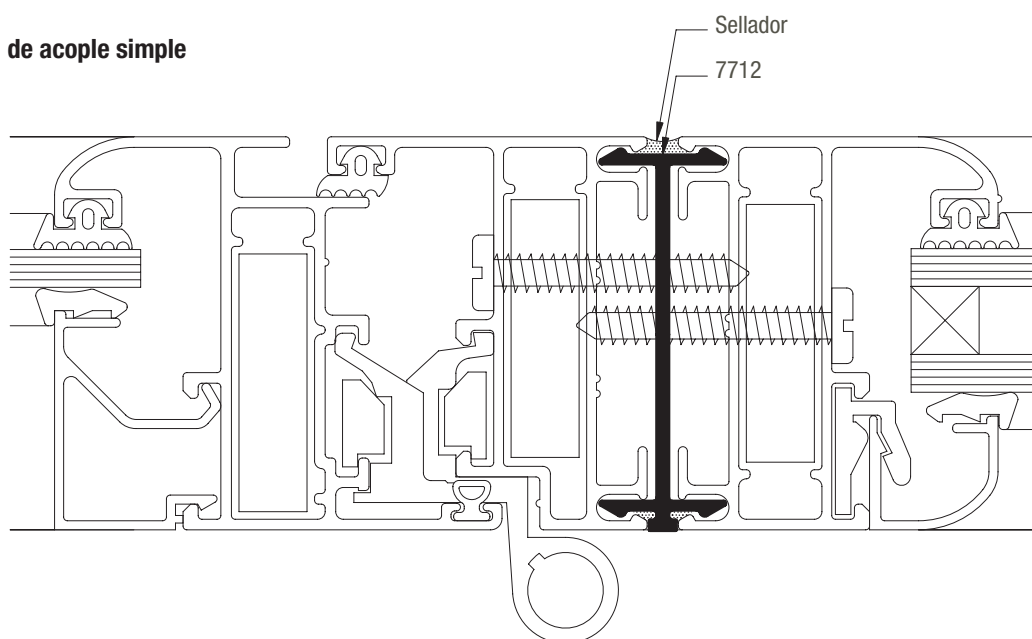

**Perfil de acople reforzado**

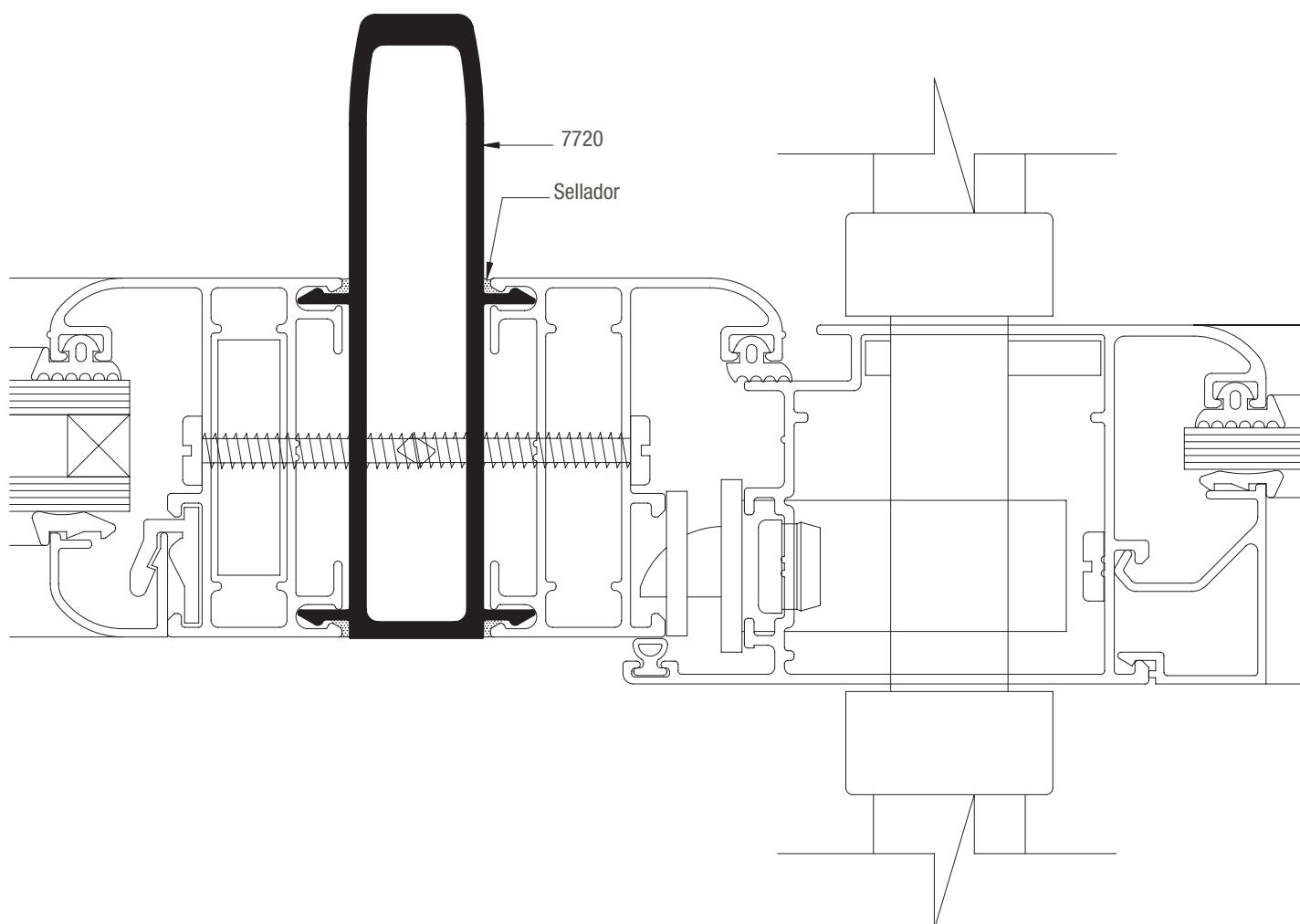

# Módena2 / perfiles de acople

Perfil de acople a 135°

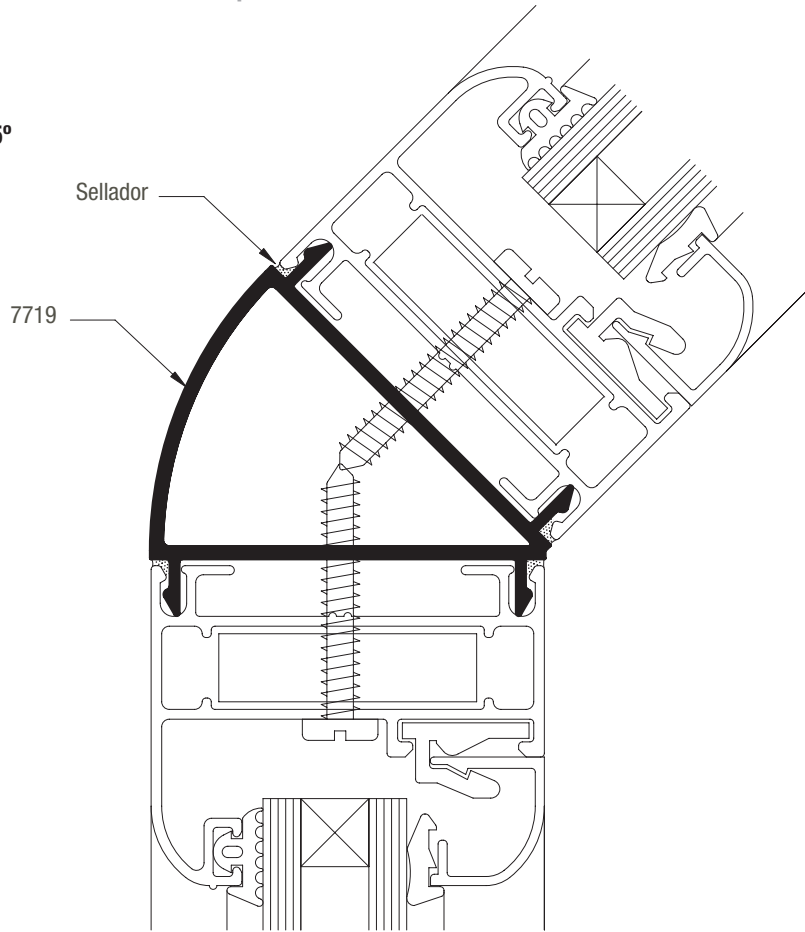

Perfil de acople a 90°

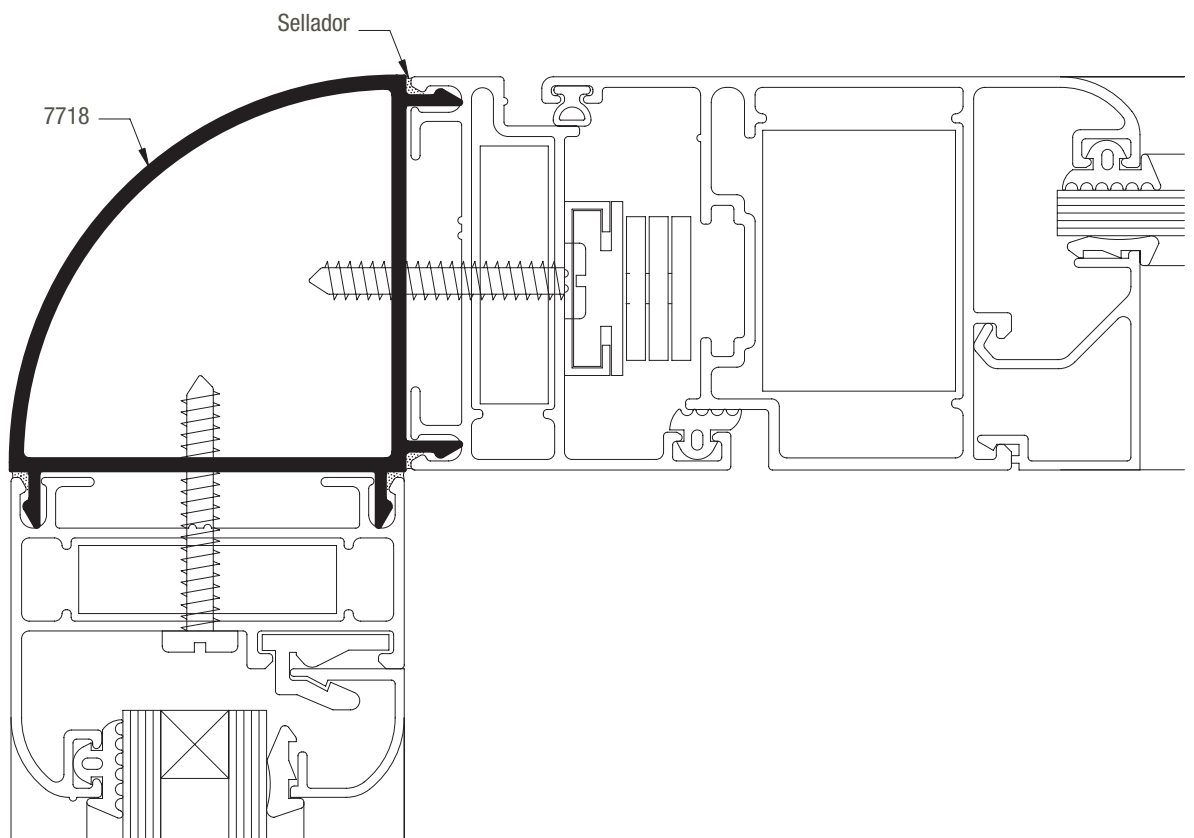

# Módena2 / uso de contravidrios

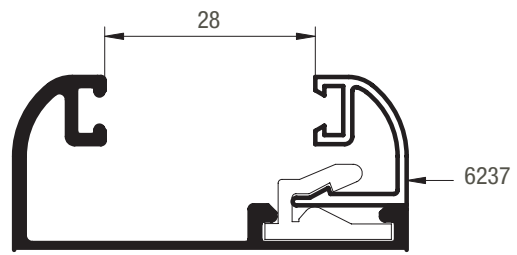
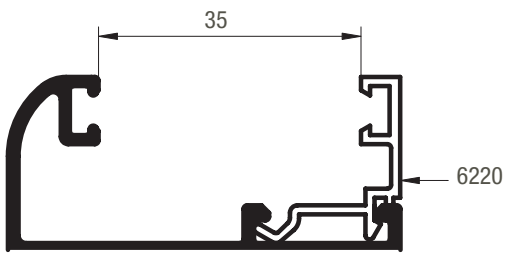
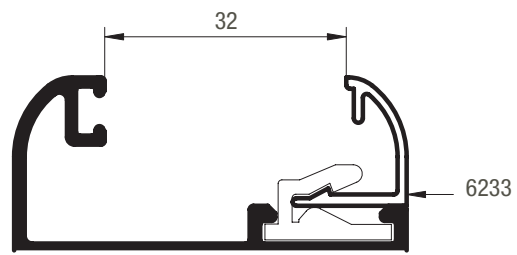
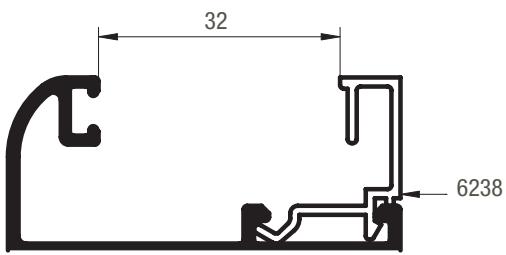
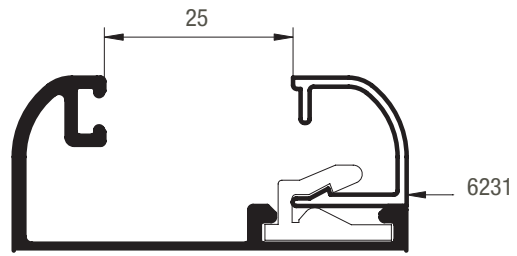
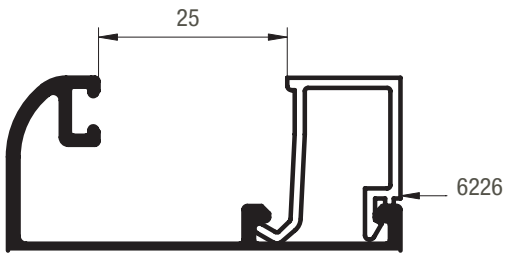
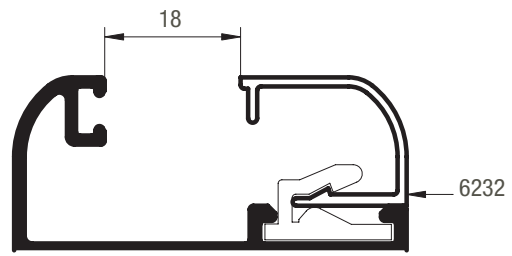
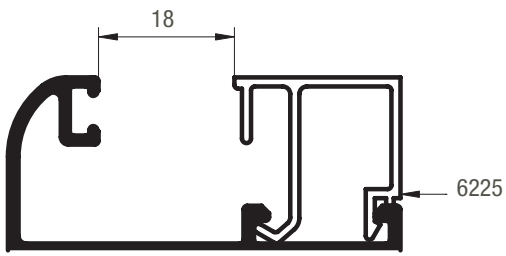
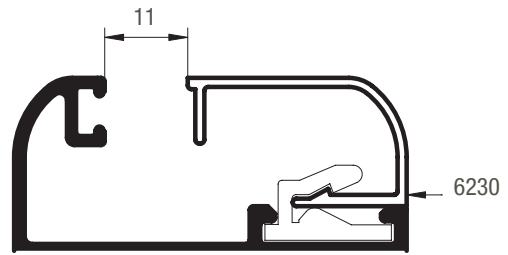
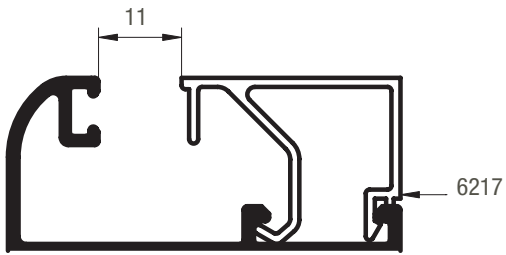

Ventana corrediza

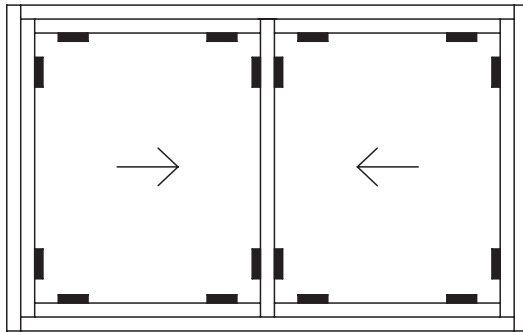

Paño fijo

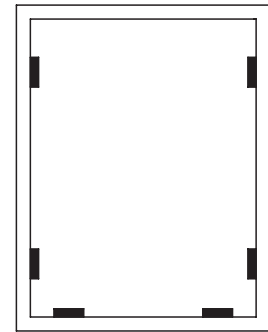

Ventana desplazable

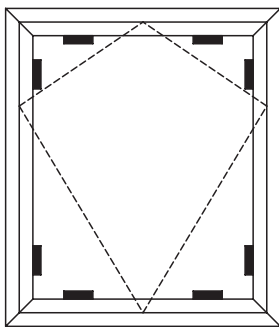

Ventana oscilobatiente

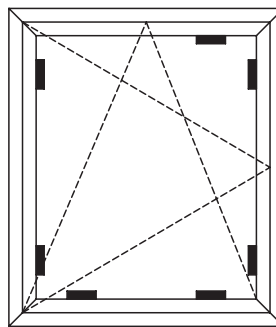

Ventana de abrir

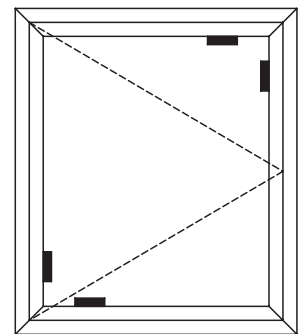

Ventana banderola

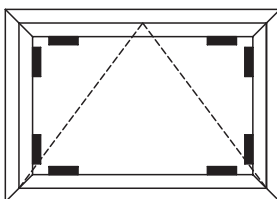

Puerta de rebatir

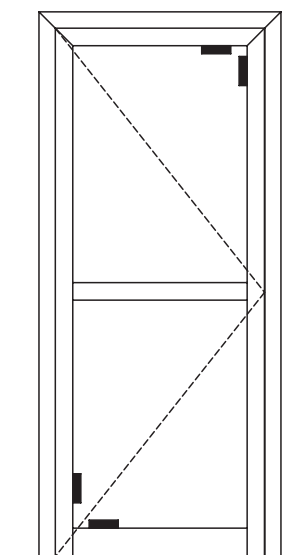

Ventana ventiluz

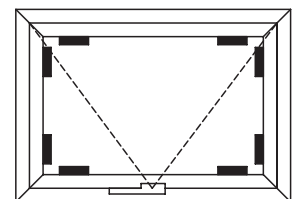

RECORTE DE ALETAS EN PARANTES

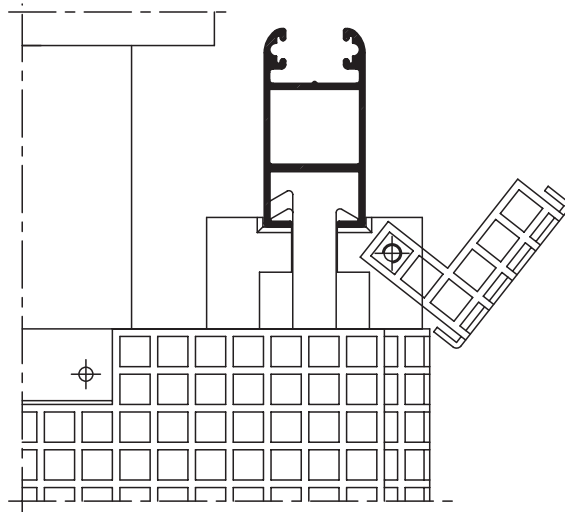

7724

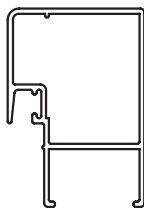

7725

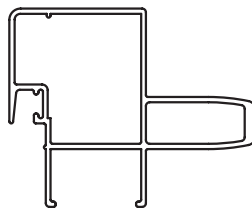

7723



7716

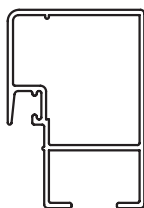

7728

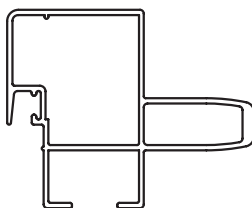

7715



RECORTE DE ALETAS EN PARANTES

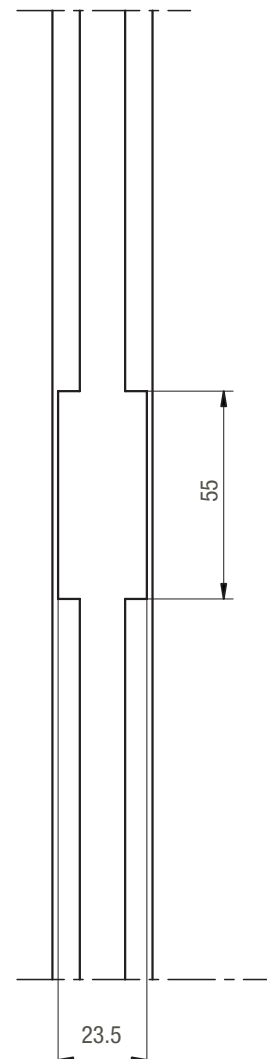
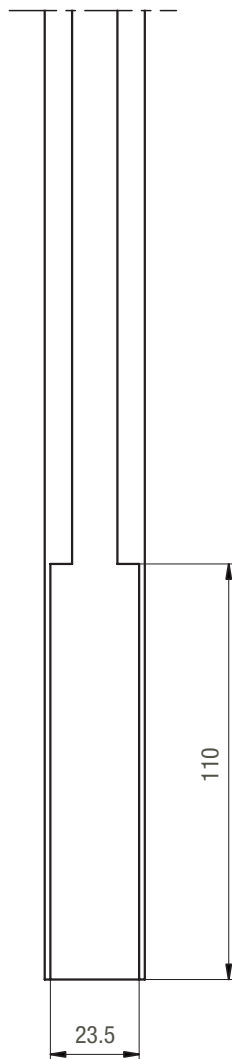
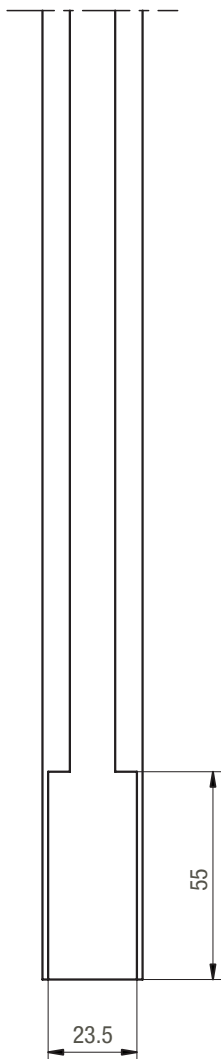
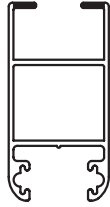
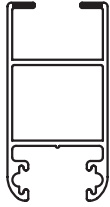

CALADO PARA COLOCACION DE ZOCALO Y CABEZAL

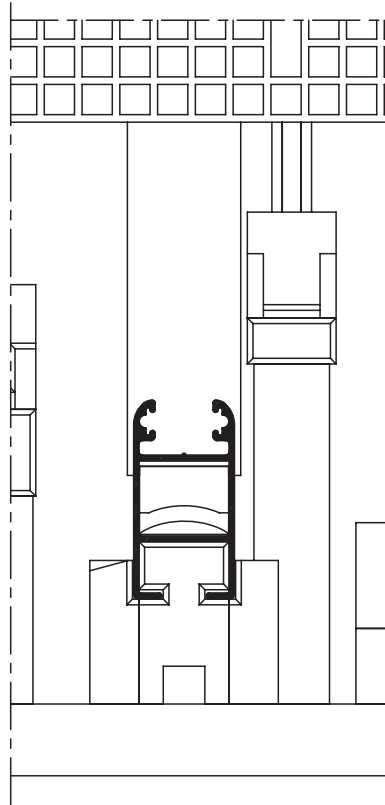

7724

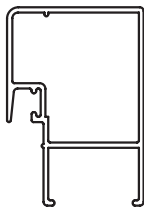

7725

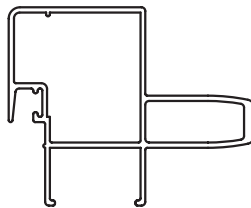

7723



7716

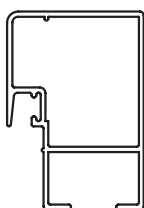

7728

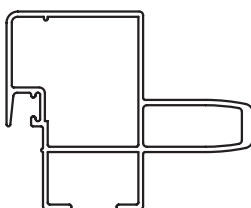

7715



Mecanizados realizados sobre la base de la Punzonadora Comall ALR021AR o Punzonadora OK M90/45.  
Se recomienda verificar la compatibilidad de acuerdo a la marca y modelo de la máquina.

CALADO PARA COLOCACION DE ZOCALO Y CABEZAL

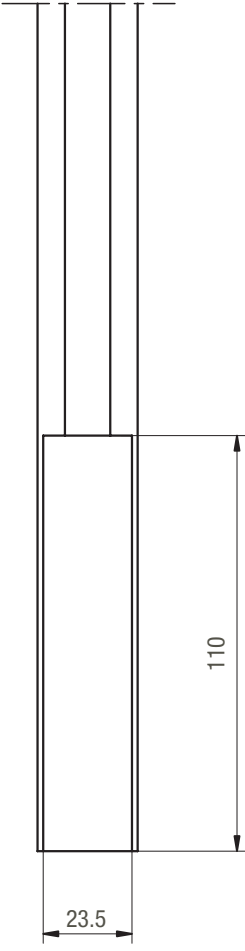
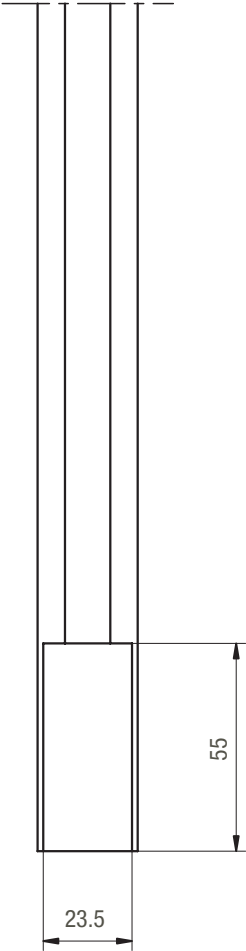
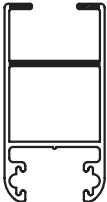
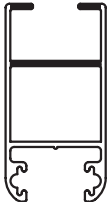

CALADO PASAGUIA Y PERFORACIONES PASA TORNILLO

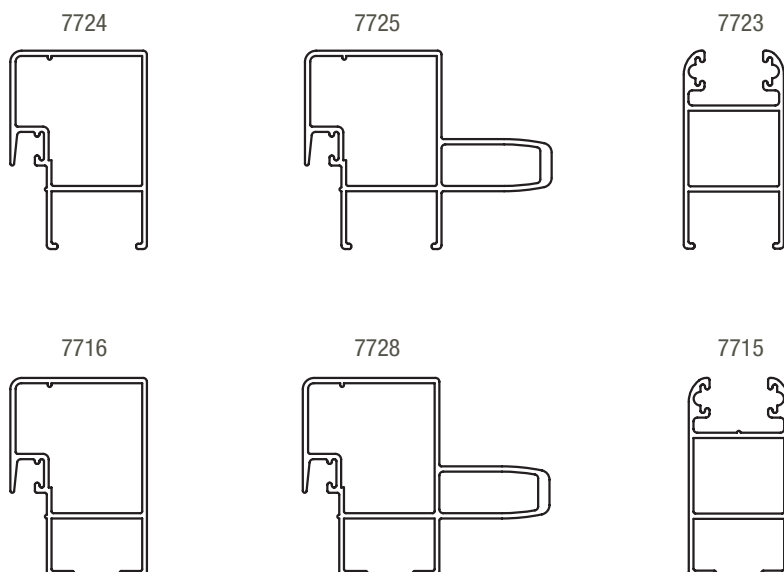
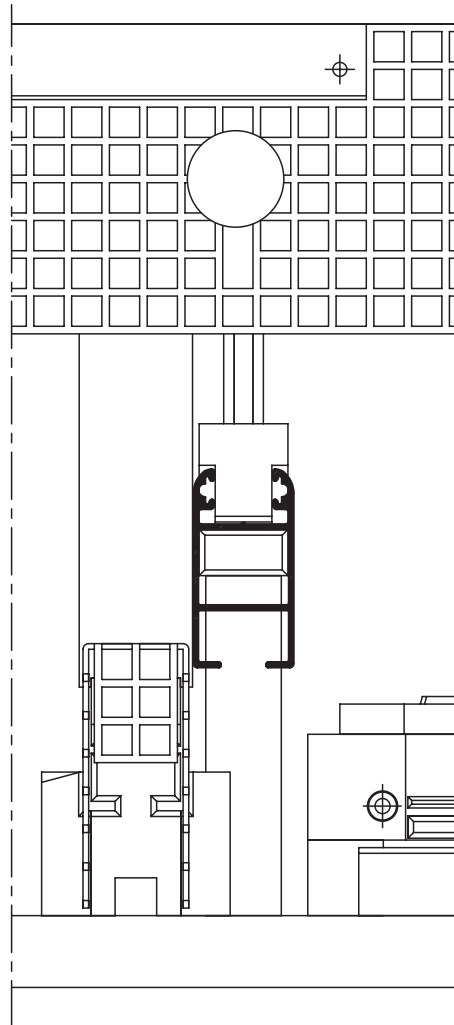

Mecanizados realizados sobre la base de la Punzonadora Comall ALR021AR o Punzonadora OK M90/45.  
Se recomienda verificar la compatibilidad de acuerdo a la marca y modelo de la máquina.

CALADO PASAGUIA Y PERFORACIONES PASA TORNILLO

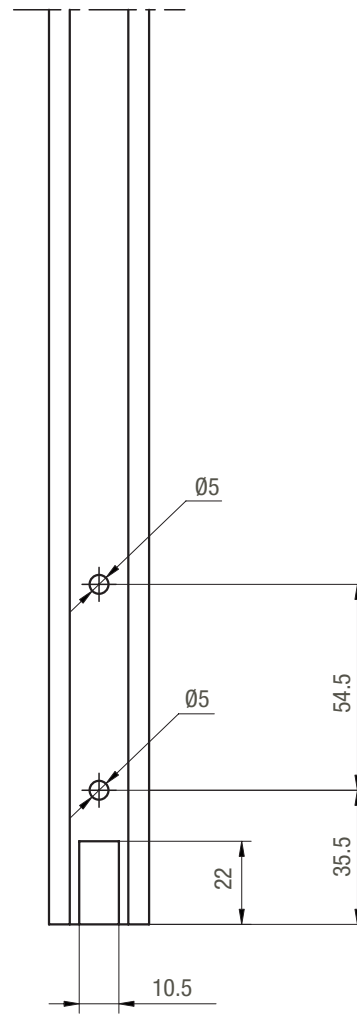
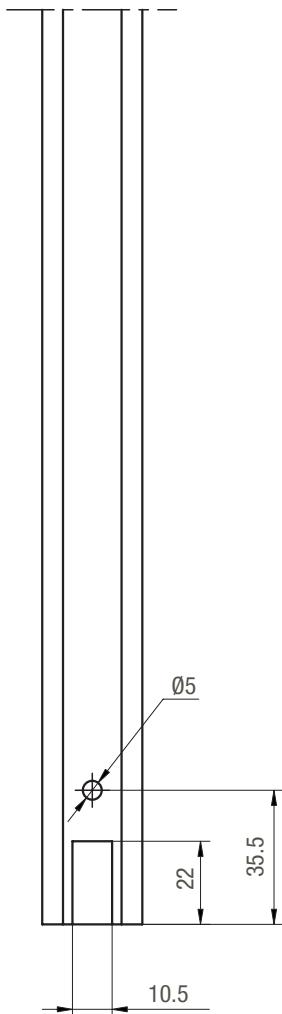

AGUJEROS JAMBA PARA UNION CON UMBRAL Y DINTEL

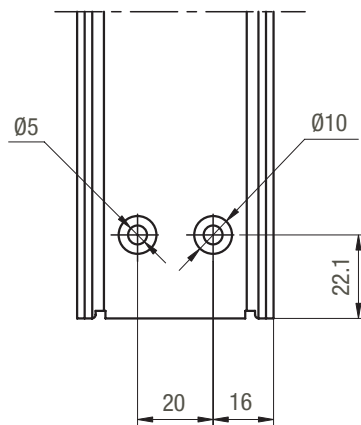
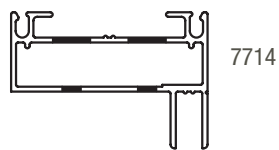
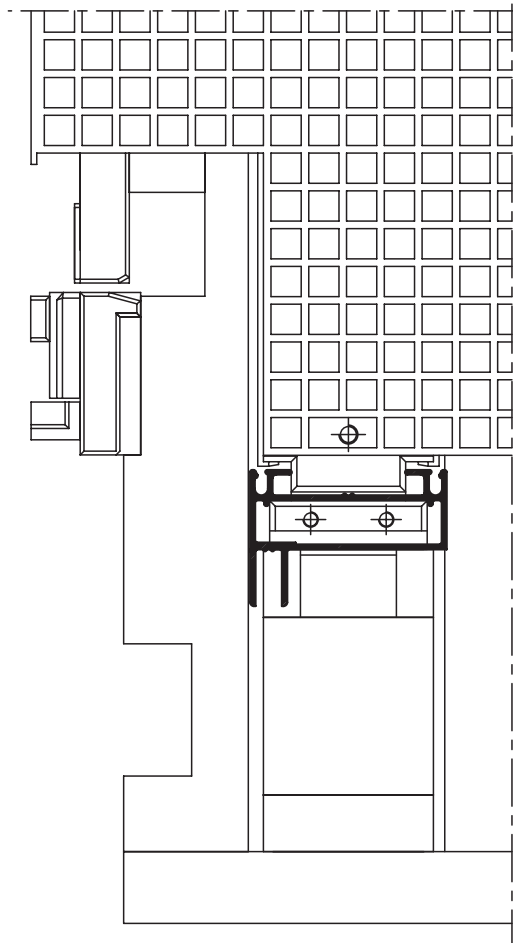

Mecanizados realizados sobre la base de la Punzonadora Comall ALR021AR o Punzonadora OK M90/45 (nueva versión modificada).  
Se recomienda verificar la compatibilidad de acuerdo a la marca y modelo de la máquina.

AGUJEROS JAMBA PARA UNION CON UMBRAL Y DINTEL

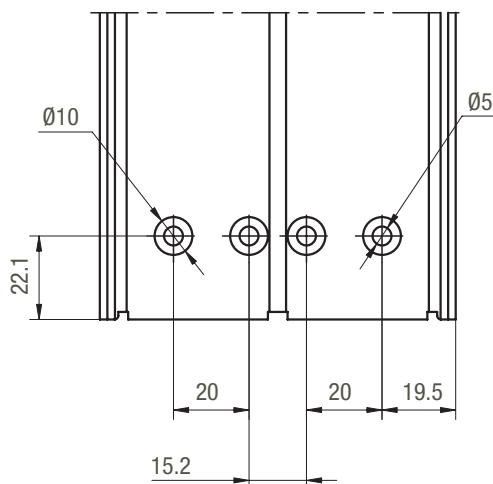
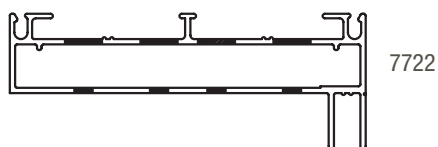
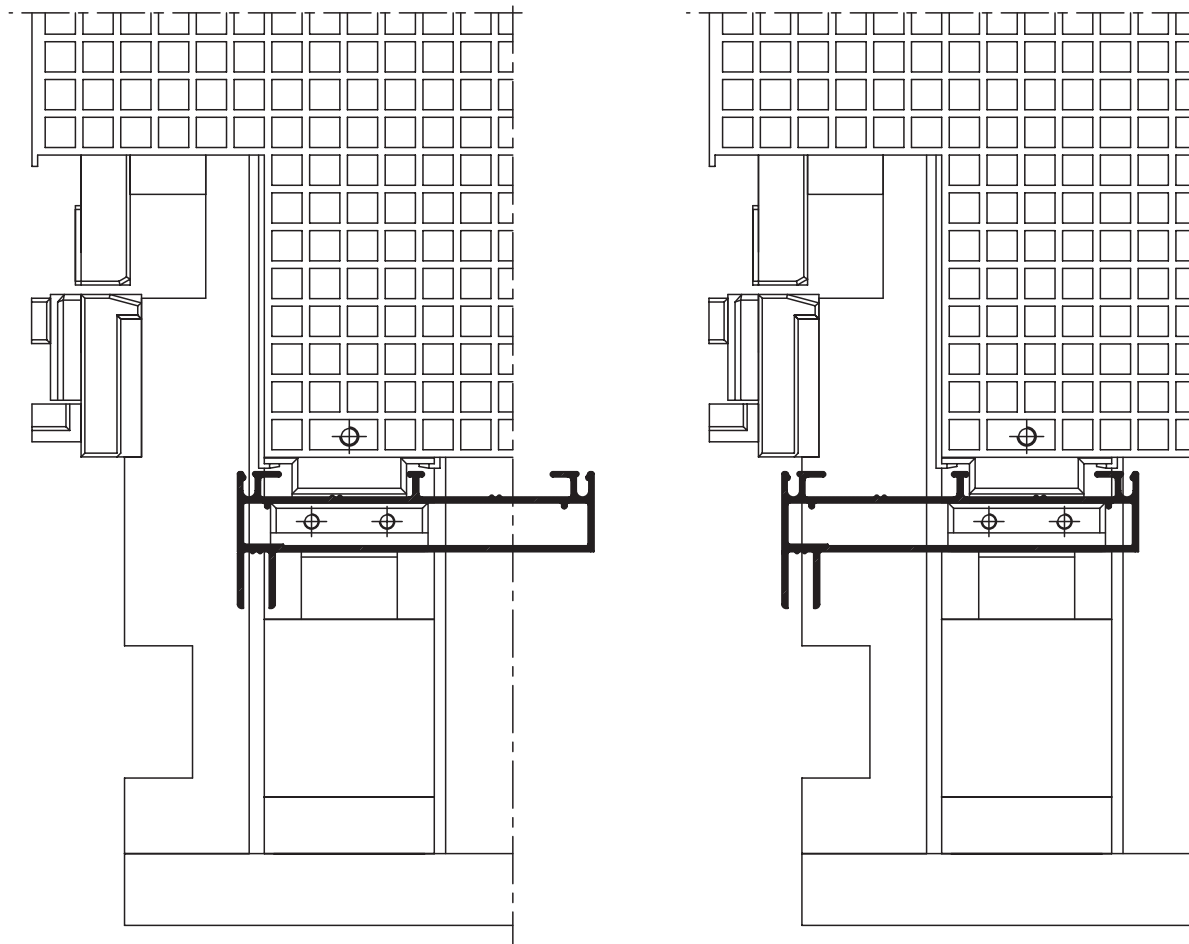

Mecanizados realizados sobre la base de la Punzonadora Comall ALR021AR o Punzonadora OK M90/45 (nueva versión modificada).  
Se recomienda verificar la compatibilidad de acuerdo a la marca y modelo de la máquina.

RECORTE ALETAS EXTERIORES DE JAMBAS

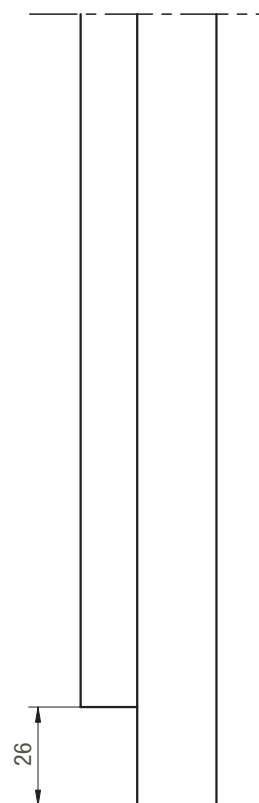
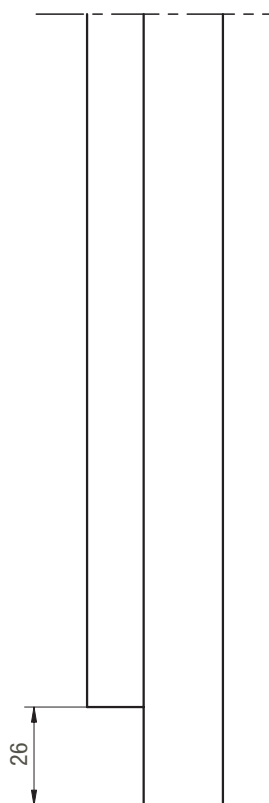
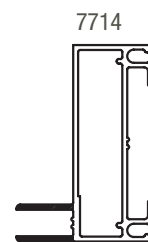
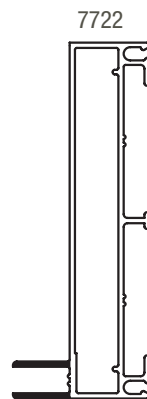
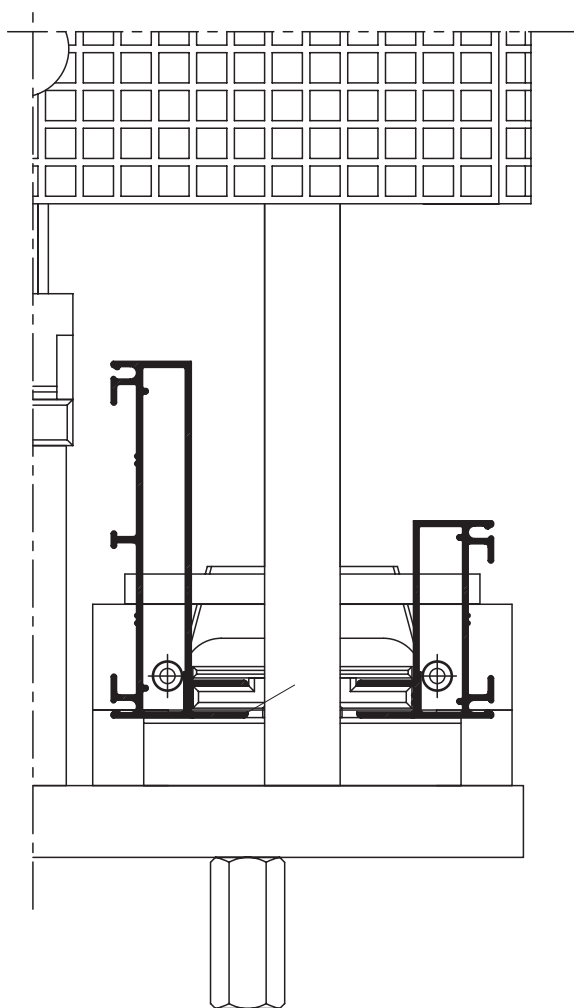

**Módena2 / mecanizados corrediza 90° y 45°**

**MECANIZADO PARA DESAGÜE GUIAS UMBRAL**

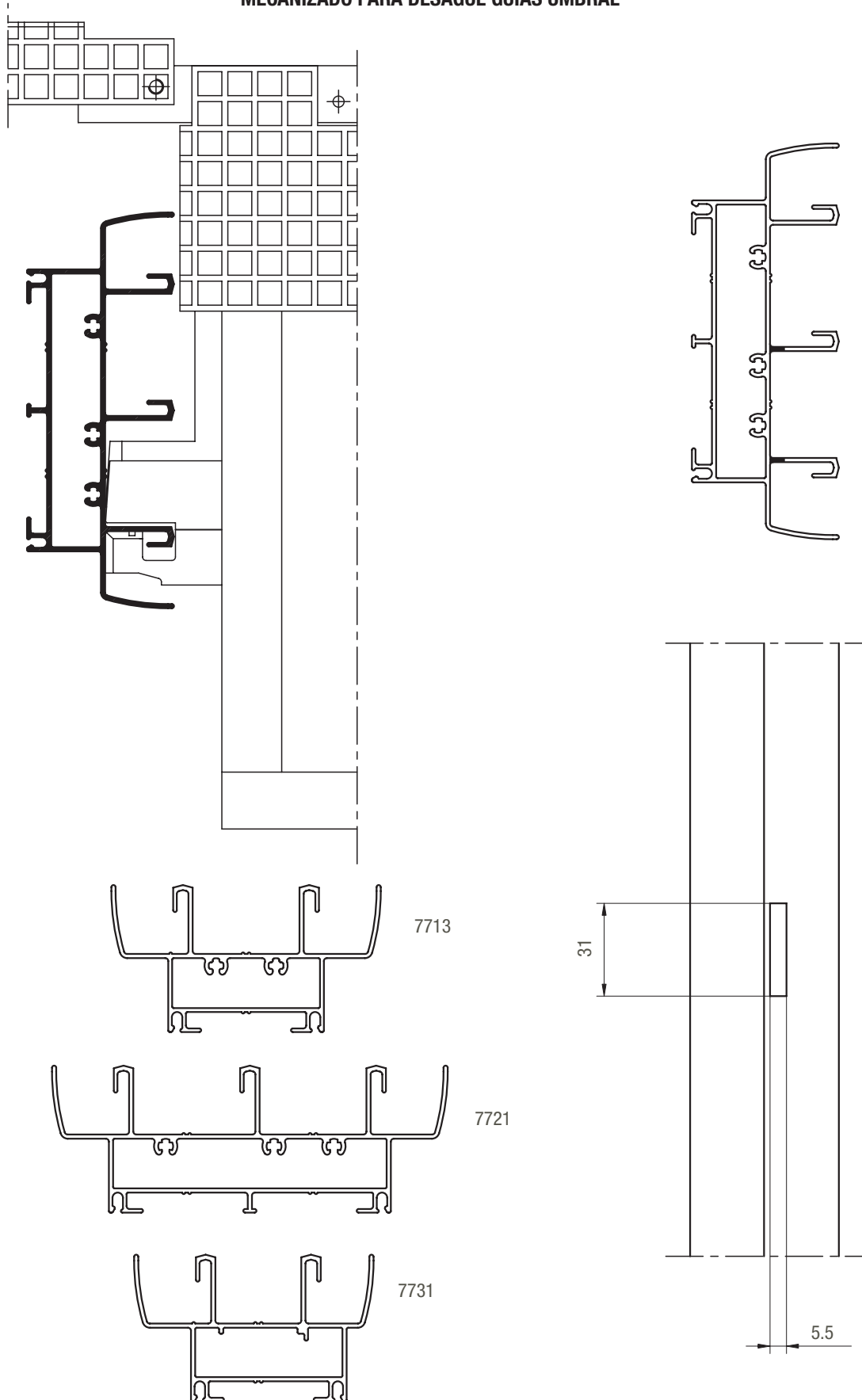

Mecanizados realizados sobre la base de la Punzonadora Comall ALR021AR o Punzonadora OK M90/45.  
Se recomienda verificar la compatibilidad de acuerdo a la marca y modelo de la máquina.

# Módena2 / mecanizados corrediza 90° y 45°

## CALADO PASAGUIA Y PERFORACIONES PASA TORNILLO

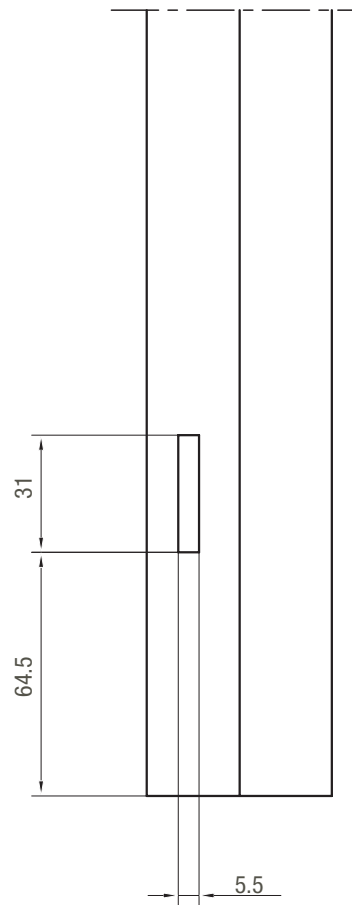
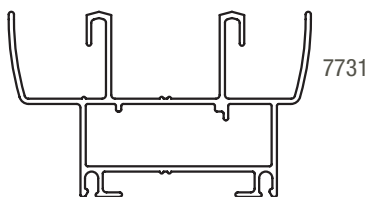
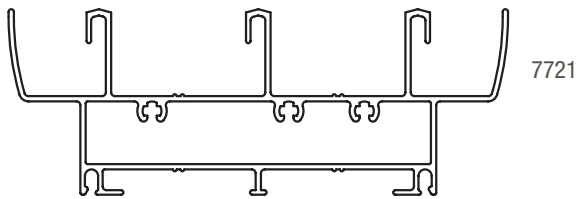
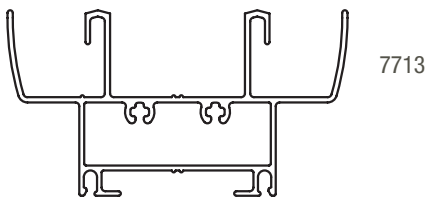
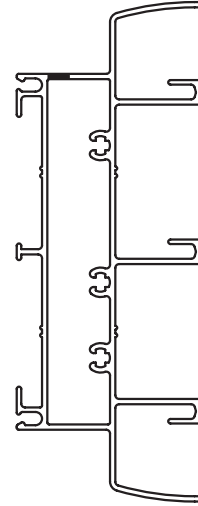
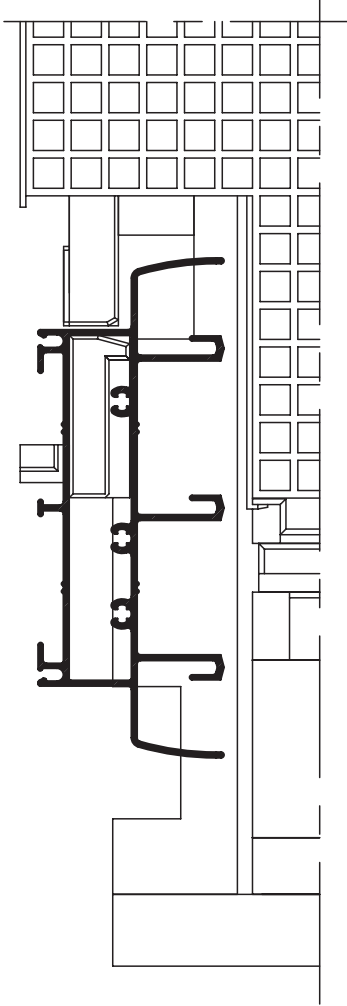

Mecanizados realizados sobre la base de la Punzonadora Comall ALR021AR o Punzonadora OK M90/45.  
Se recomienda verificar la compatibilidad de acuerdo a la marca y modelo de la máquina.

# Módena2 / mecanizados corrediza 90° y 45°

## DESAGÜE ALETA EXTERIOR UMBRAL

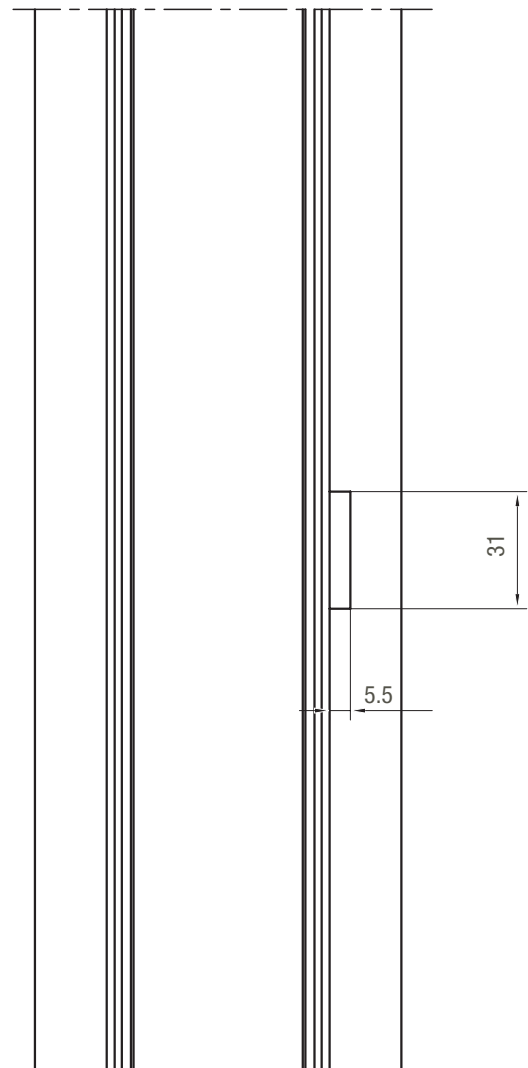
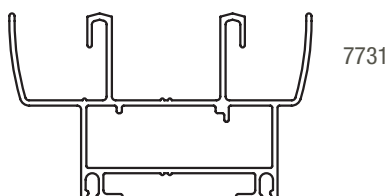
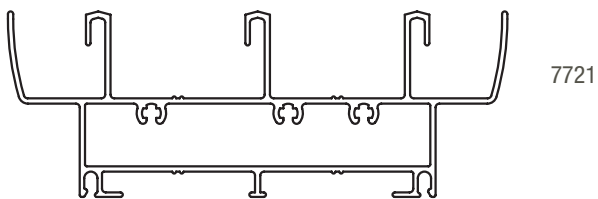
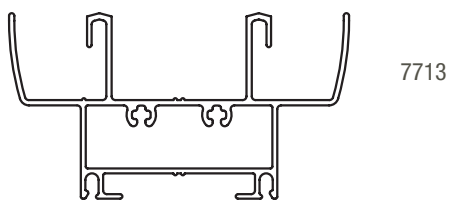
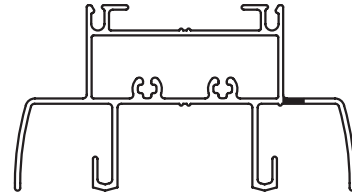
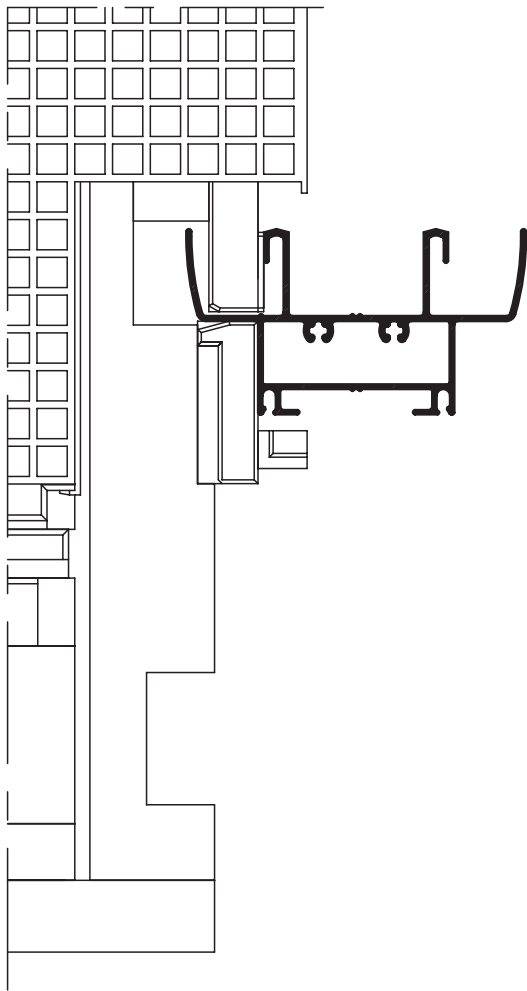

RECORTE ALETAS ENCUENTRO CENTRAL

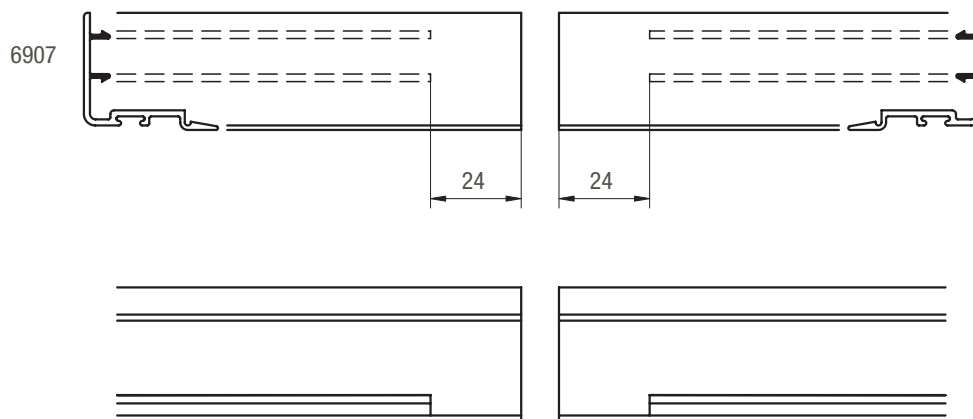
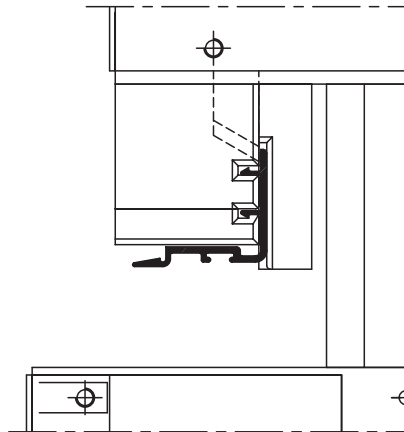

**CALADO PASAGUIA Y AGUJERO TAPON**

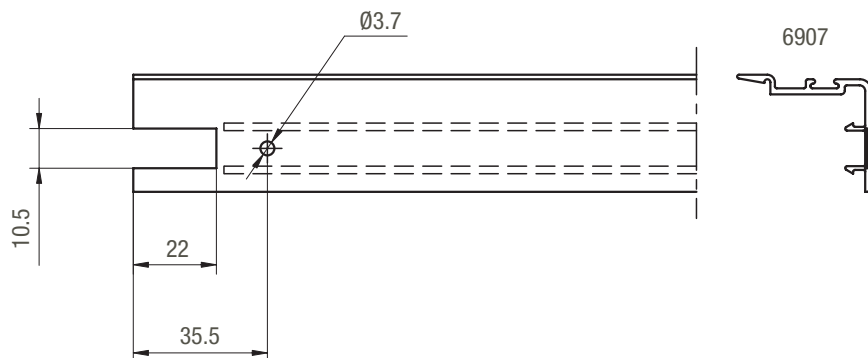
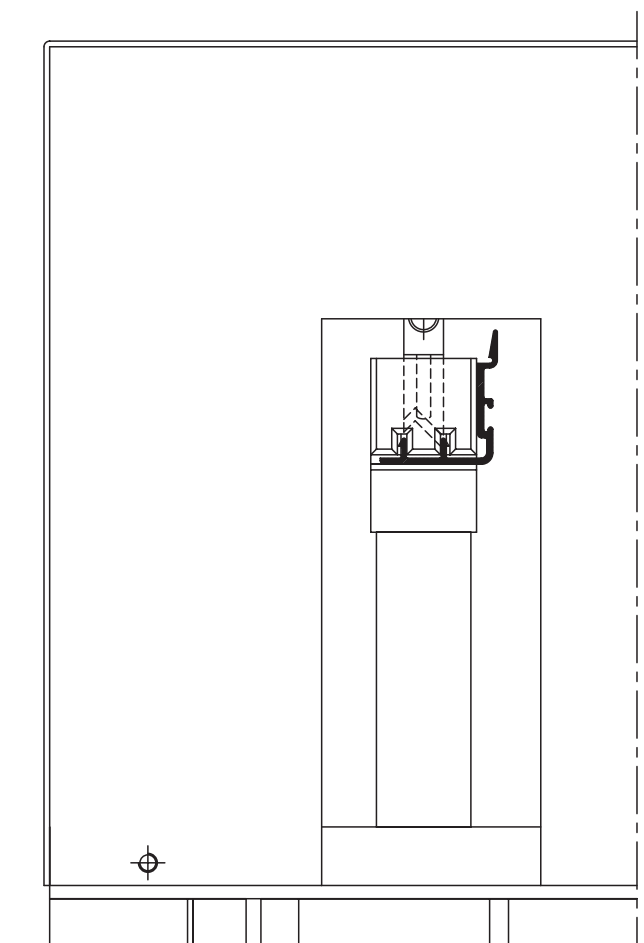

MECANIZADO PARA ESCUADRA

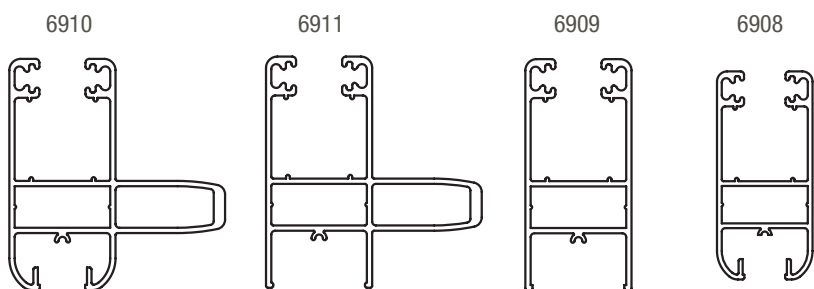
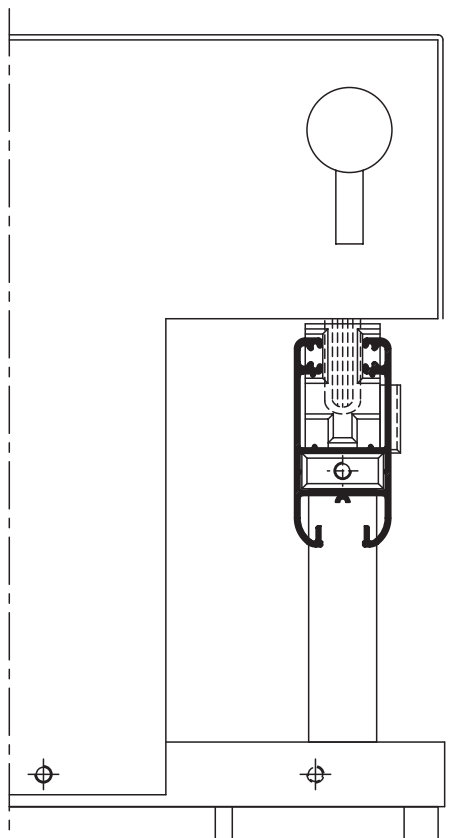

Mecanizados realizados sobre la base de la Punzonadora Comall ZOX14310 o Punzonadora OK M90/45.  
Se recomienda verificar la compatibilidad de acuerdo a la marca y modelo de la máquina.

# Módena2 / mecanizados corrediza 45°

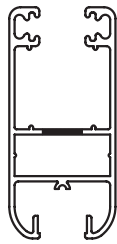

- 6908
- 6909
- 6910
- 6911

## MECANIZADO PARA ESCUADRA

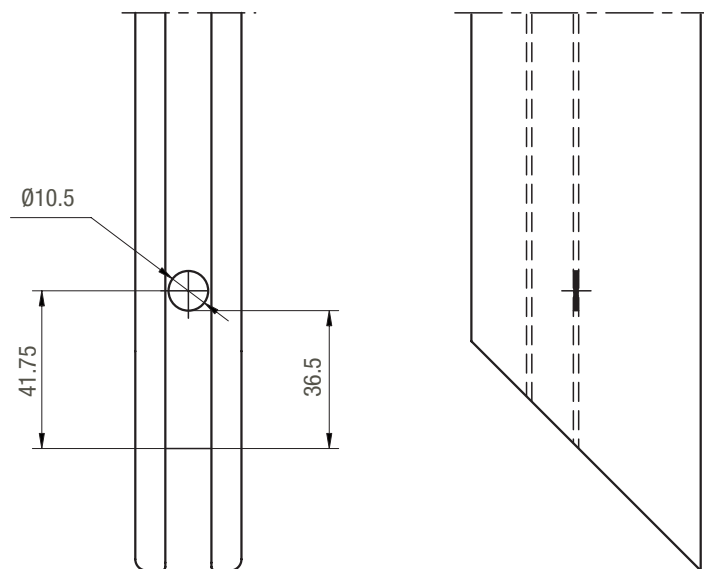
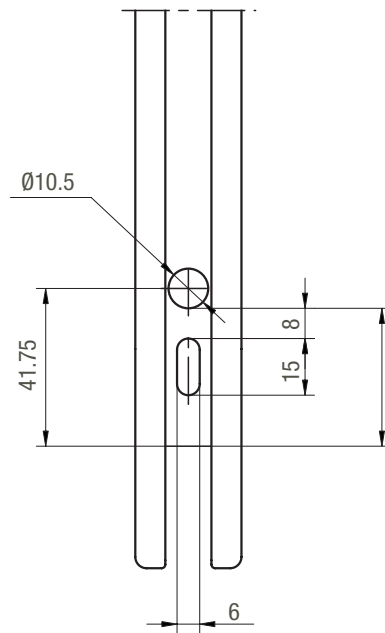

Mecanizados realizados sobre la base de la Punzonadora Comall ZOX14310 o Punzonadora OK M90/45.  
Se recomienda verificar la compatibilidad de acuerdo a la marca y modelo de la máquina.

MECANIZADO PARA ESCUADRA

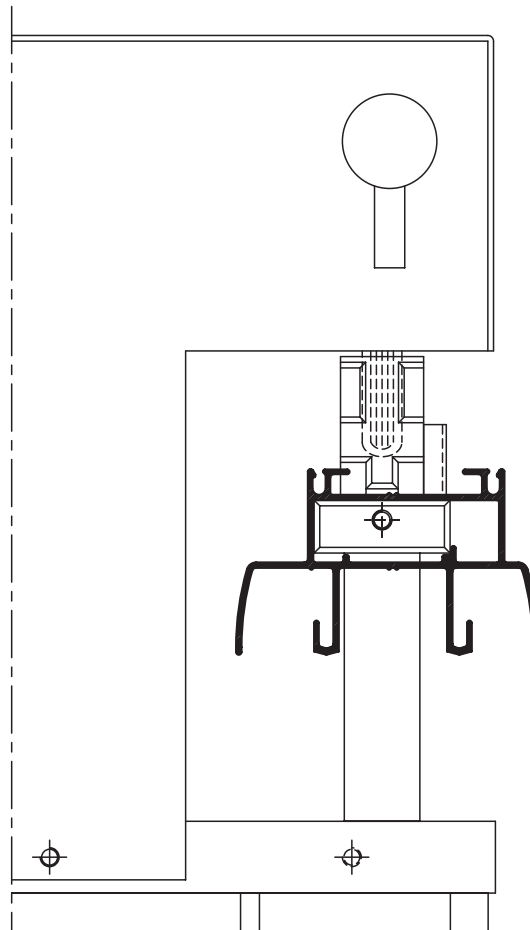

7731

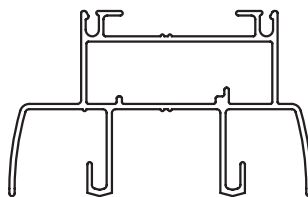

Mecanizados realizados sobre la base de la Punzonadora Comall ZOX14310 o Punzonadora OK M90/45.  
Se recomienda verificar la compatibilidad de acuerdo a la marca y modelo de la máquina.

# Módena2 / mecanizados corrediza 45°

## MECANIZADO PARA ESCUADRA

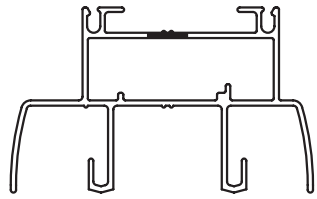

7731

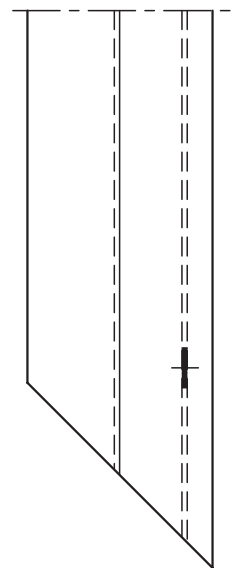
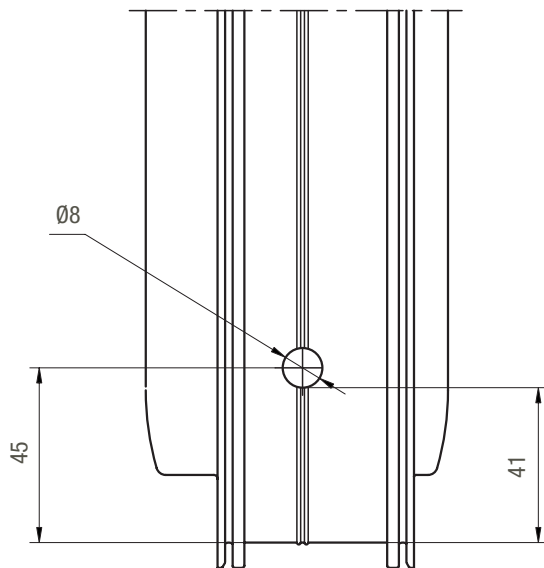
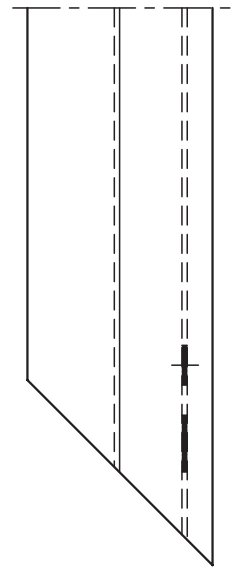
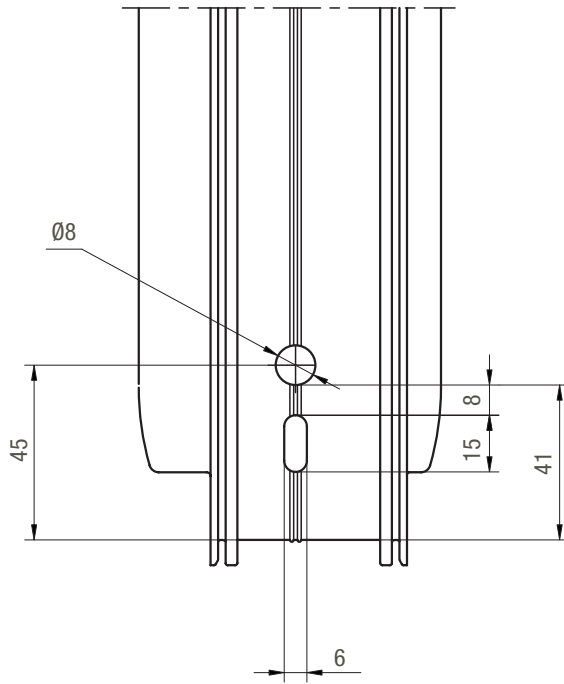

Mecanizados realizados sobre la base de la Punzonadora Comall ZOX14310 o Punzonadora OK M90/45. Se recomienda verificar la compatibilidad de acuerdo a la marca y modelo de la máquina.

# Módena2 / mecanizados corrediza 90°

## FRESADO PARANTE REFORZADO

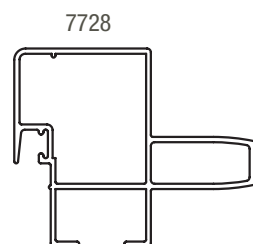
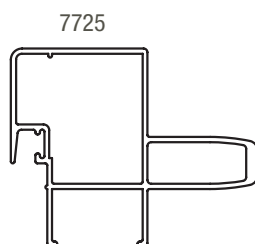
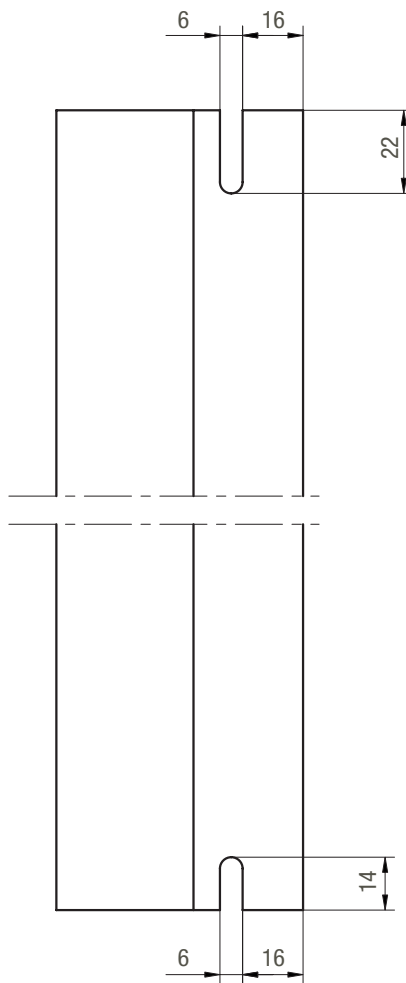
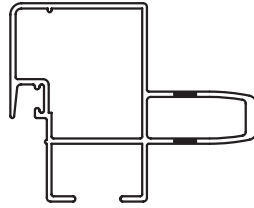

# Módena2 / mecanizados corrediza 90° y 45°

## MECANIZADO PARA CIERRES LATERALES

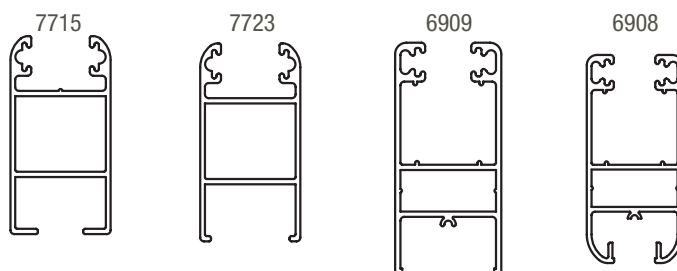
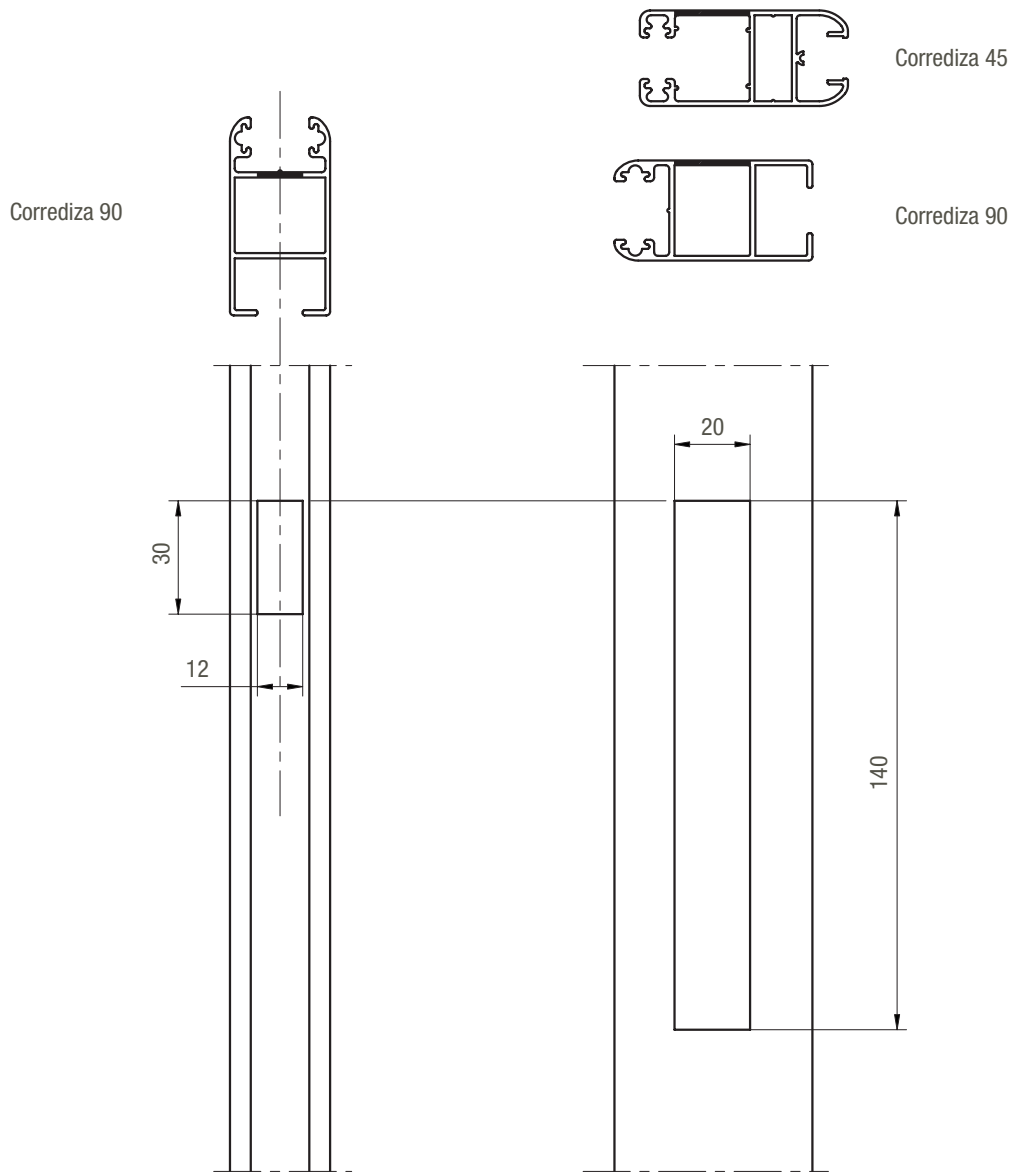

Mecanizados de cierres indicativos  
Se recomienda verificar medidas de acuerdo al tipo de cierre a utilizar.

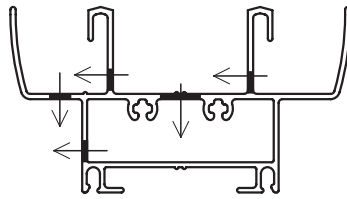

**MECANIZADOS UMBRAL**

7713

7721

7731

LADO EXTERIOR

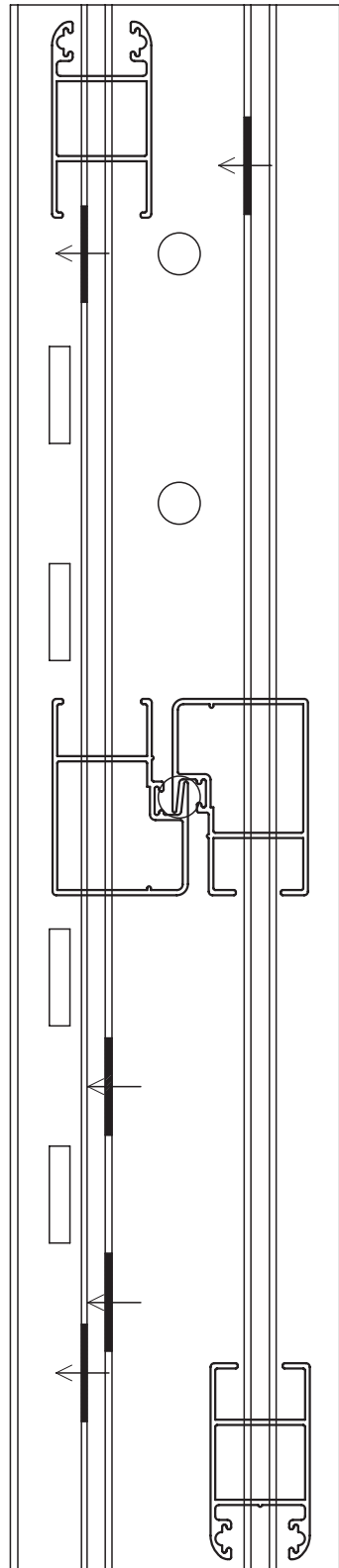

LADO INTERIOR

CALADO PARA DESAGÜE T131

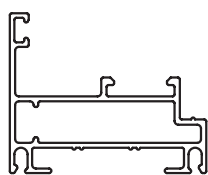
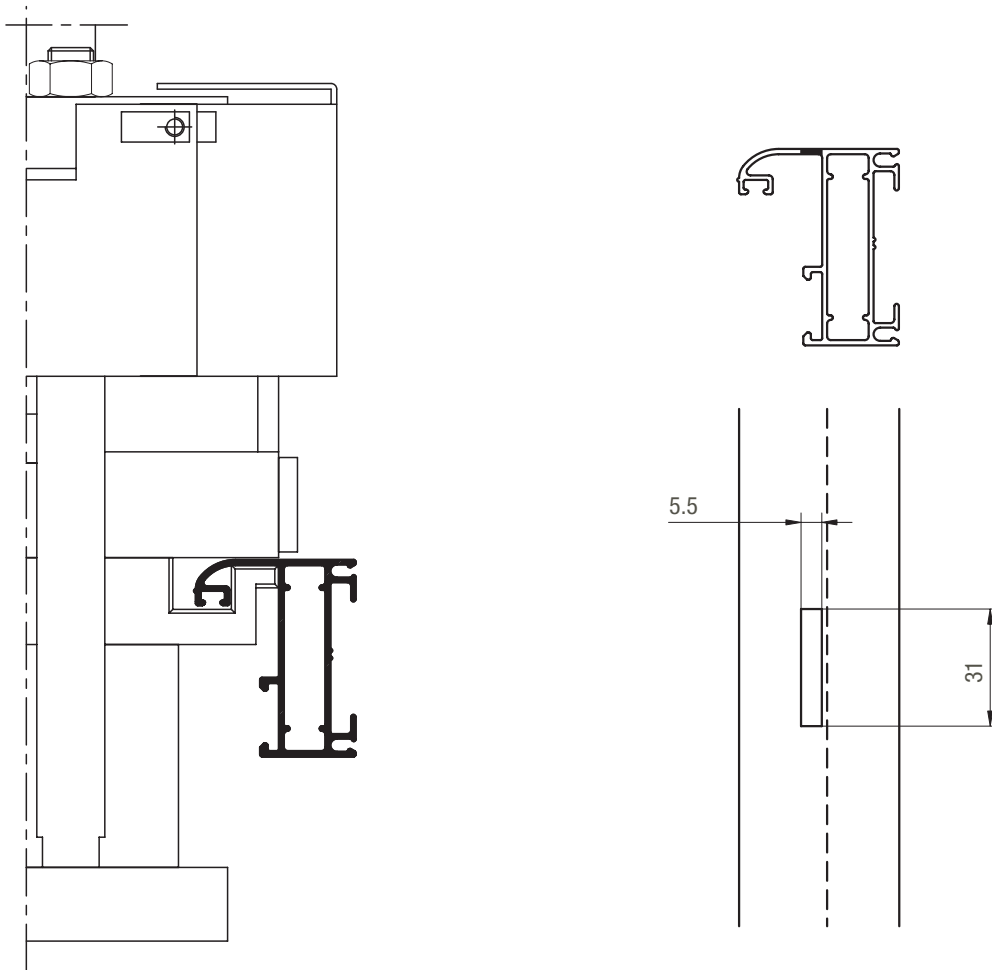

7707

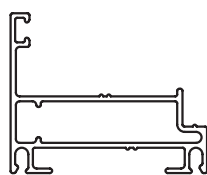

7709

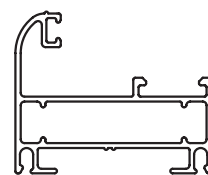

7705

Mecanizados realizados sobre la base de la Punzonadora Comall ZOX14310 o Punzonadora OK M90/45.  
Se recomienda verificar la compatibilidad de acuerdo a la marca y modelo de la máquina.

MECANIZADO PARA ESCUADRA

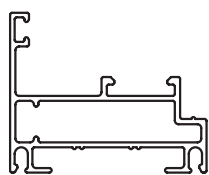
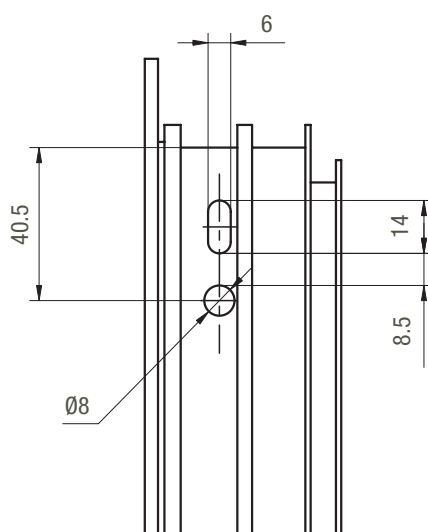
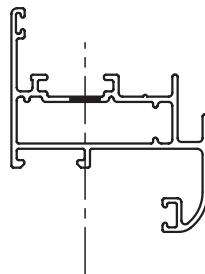
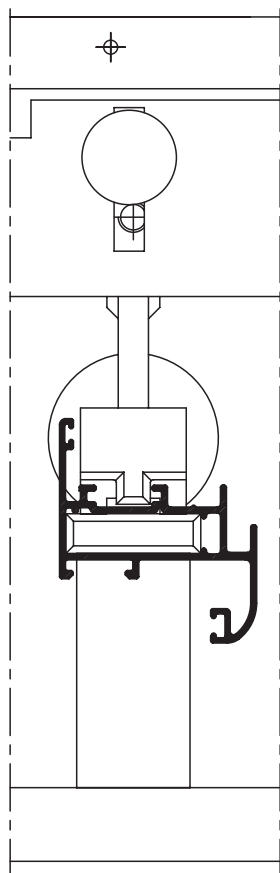

7707

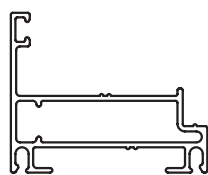

7709

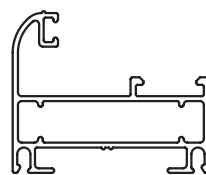

7705

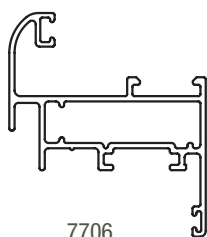

7706

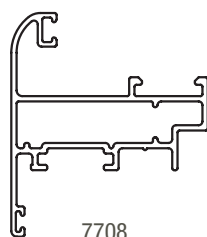

7708

Mecanizados realizados sobre la base de la Punzonadora Comall ZOX14310 o Punzonadora OK M90/45. Se recomienda verificar la compatibilidad de acuerdo a la marca y modelo de la máquina.

## MECANIZADO PARA ESCUADRA

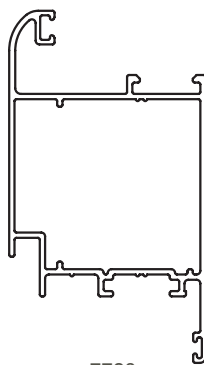
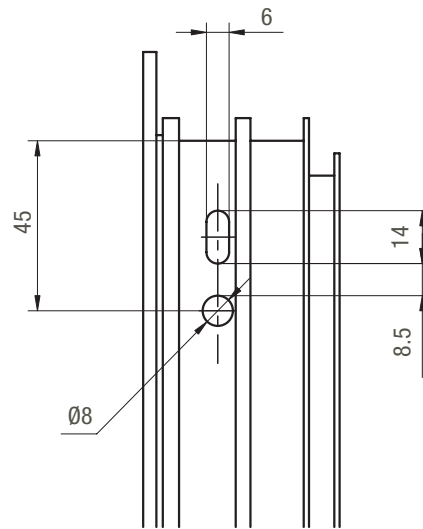
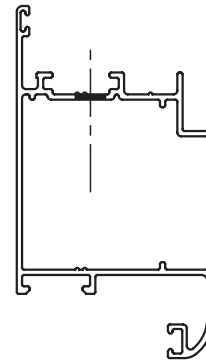
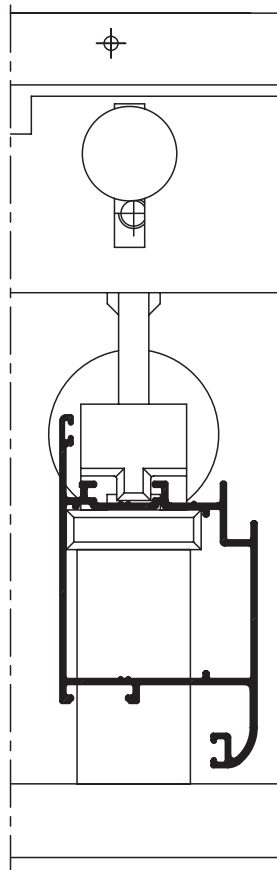

7726

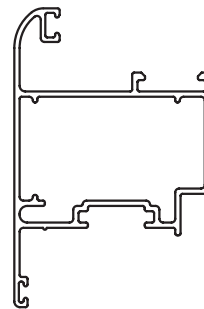

7710

MECANIZADO PARA COLOCACION DE FALLEBA

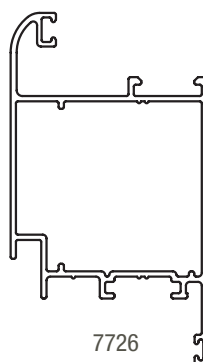
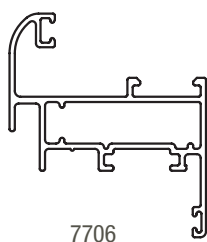
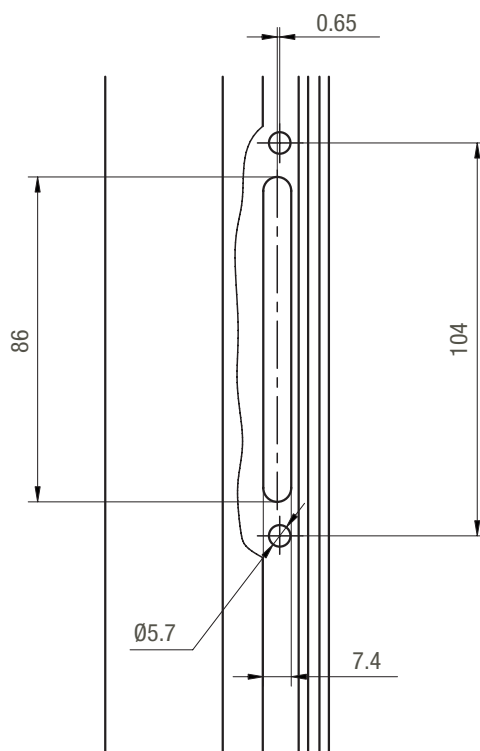
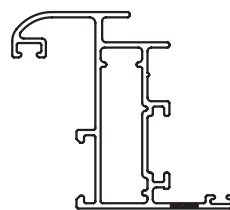
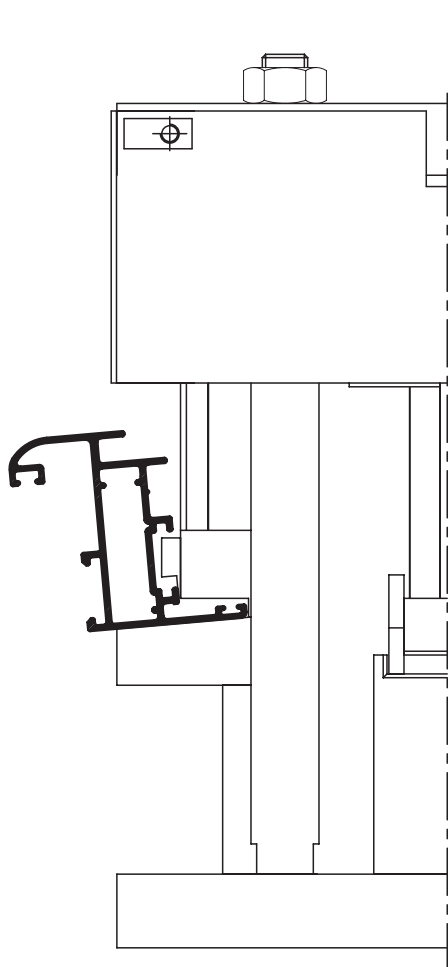

Mecanizados realizados sobre la base de la Punzonadora Comall ZOX14310 o Punzonadora OK M90/45.  
Se recomienda verificar la compatibilidad de acuerdo a la marca y modelo de la máquina.

MECANIZADO ALETAS PARA PASAJE PLETINA

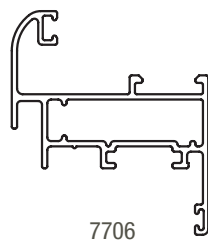
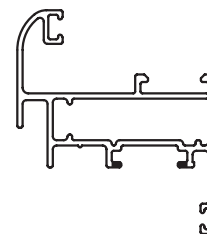
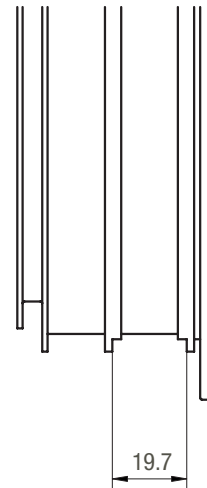
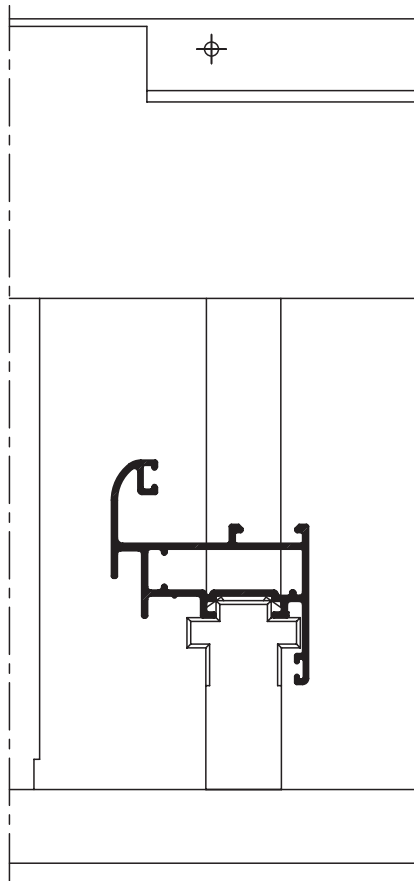

7706

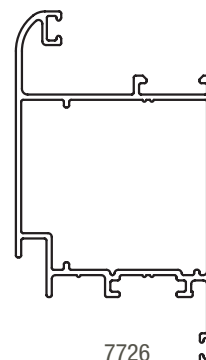

7726

MECANIZADO PASAJE TORNILLOS PUERTA DE REBATIR

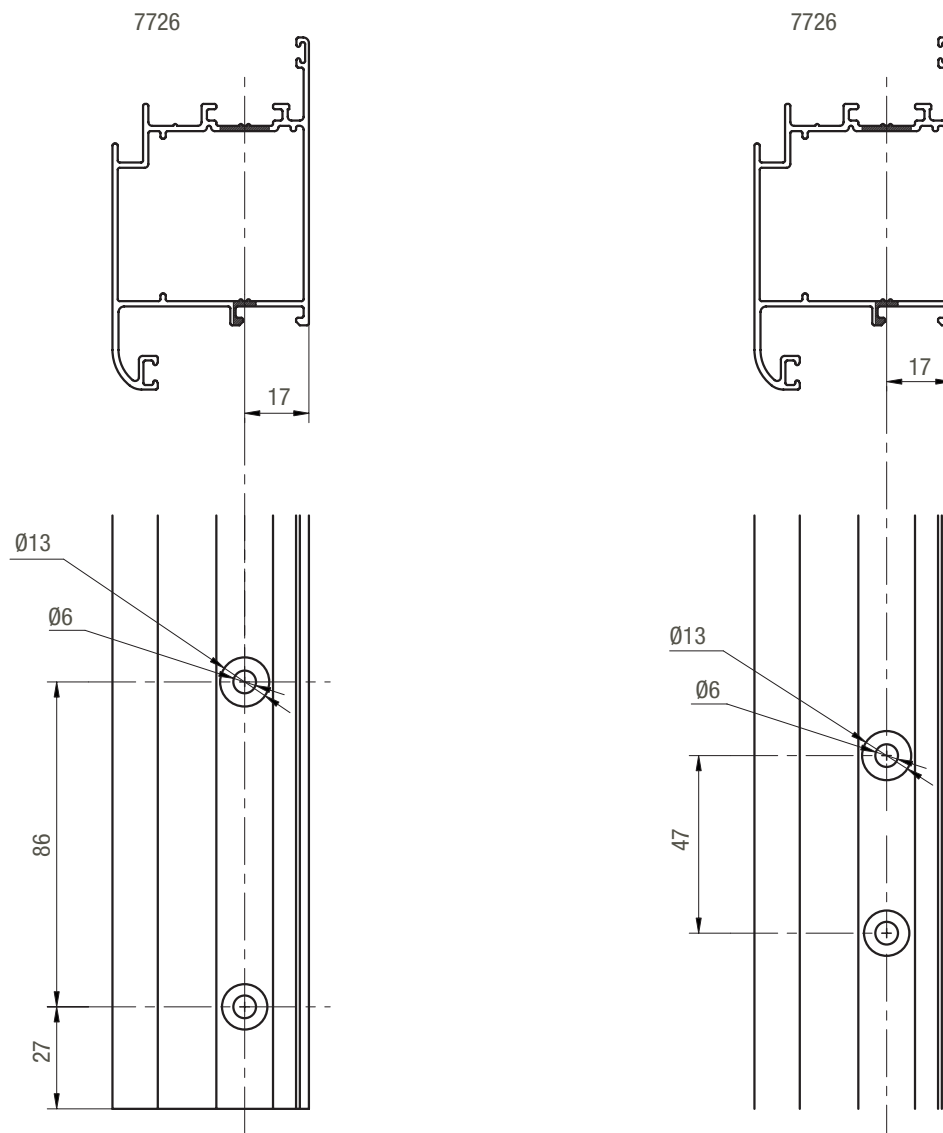

FRESADO DE ALETAS TRAVESAÑO Y ZOCALO PUERTA  
TRAVESAÑO PAÑO FIJO

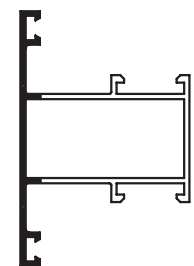
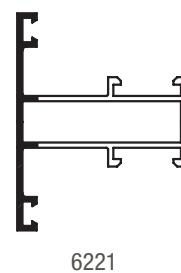
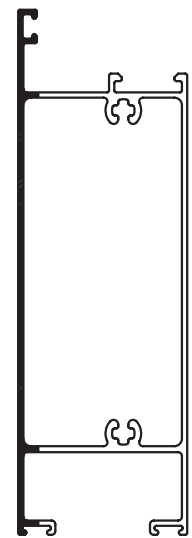
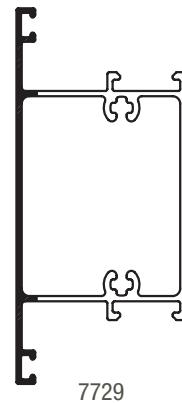
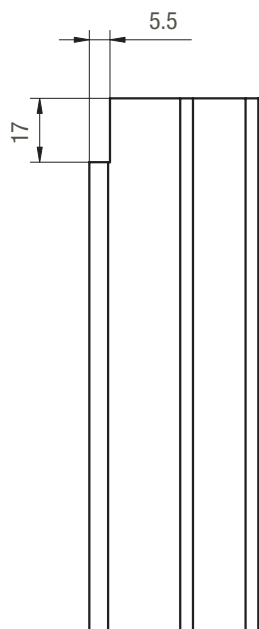
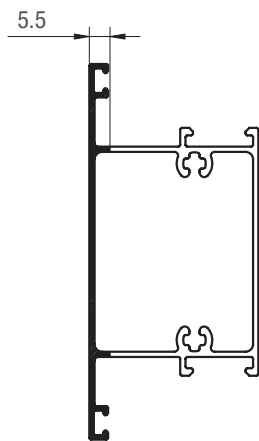

7730

6222

## Módena2 / dimensiones de fabricación corrediza corte a 90°

**Parante central 7716-7716**

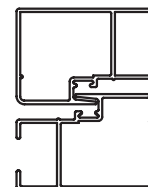
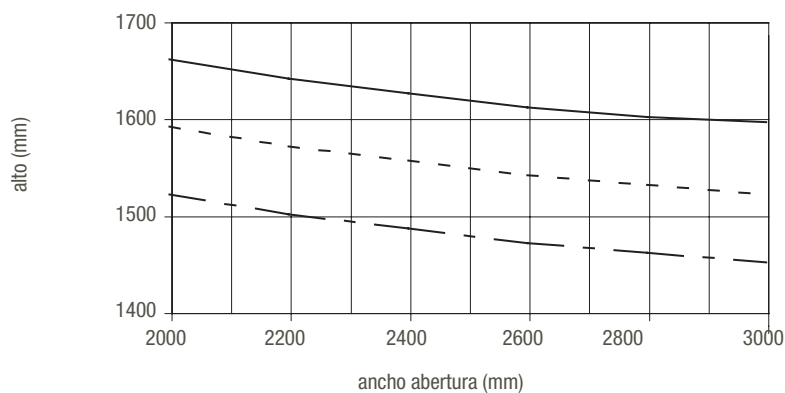

**Parante central 7716-7728**

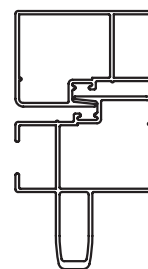
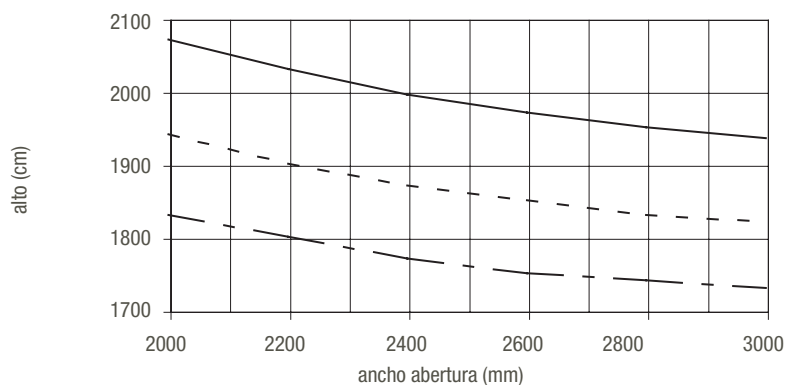

**Parante central 7728-7728**

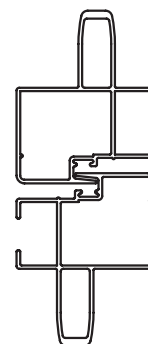
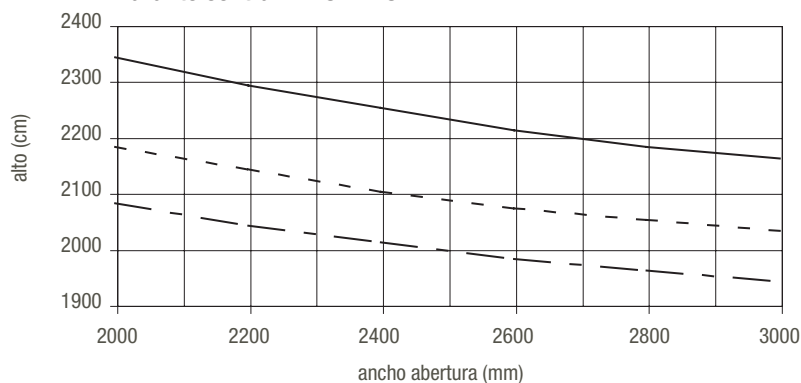

### Referencias generales

—————	80 kg/m <sup>2</sup>
- - - - -	100 kg/m <sup>2</sup>
- · - · -	120 kg/m <sup>2</sup>

### Peso máximo de hoja:

Con ruedas simples R39/R40: 40 kg

Con ruedas dobles R41/R42: 80 kg

Las curvas son indicativas y muestran diferentes combinaciones de anchos, altos y presiones de viento, de acuerdo a los parantes centrales que se utilicen (vidrio simple). Se recomienda para ancho de hoja superior a 800 mm y alto superior a 1600 mm usar como zócalo de hoja el perfil 6209. Para ancho de hoja superior a 1000 mm y alto superior a 2000 mm, usar como zócalo y cabezal de hoja el perfil 6209.

## Módena2 / dimensiones de fabricación corrediza corte a 45°

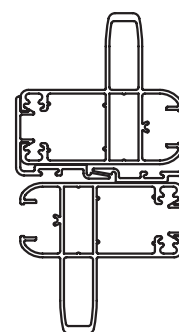
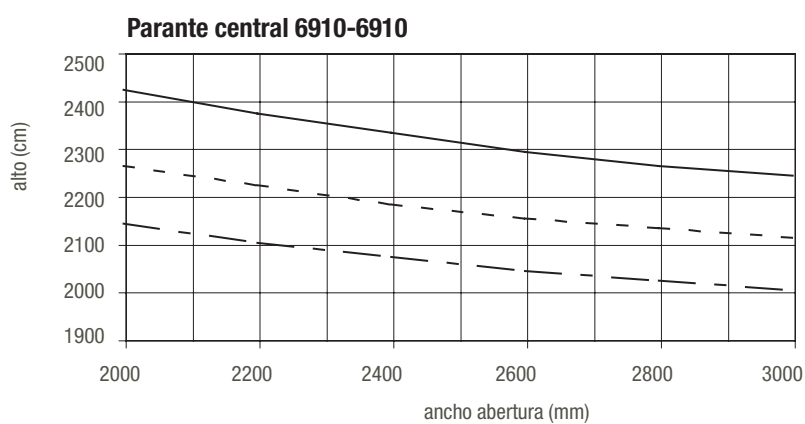
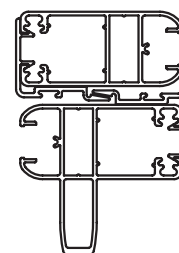
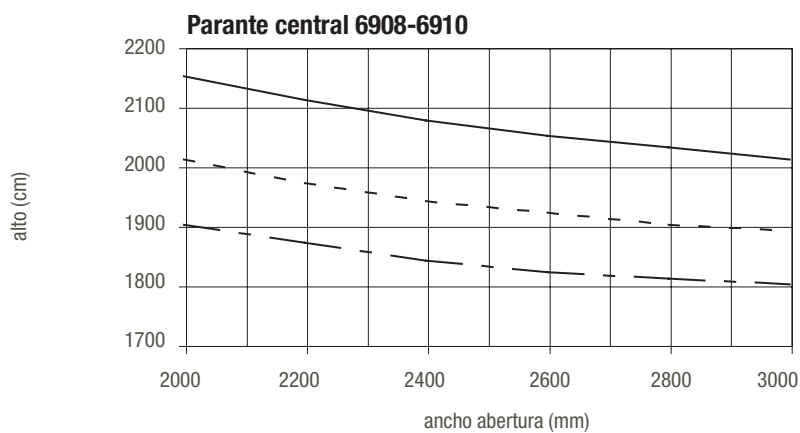
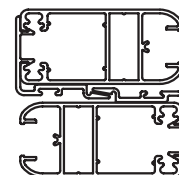
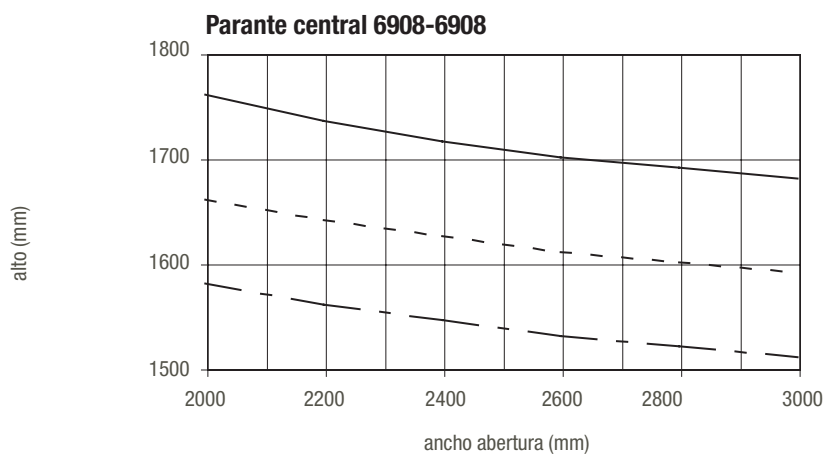

### Peso máximo de hoja:

Con ruedas simples R48: 40 kg

Con ruedas dobles R49: 80 kg

Las curvas son indicativas y muestran diferentes combinaciones de anchos, altos y presiones de viento, de acuerdo a los parantes centrales que se utilicen (vidrio simple).

### Referencias generales

- 80 kg/m<sup>2</sup>
- - - - - 100 kg/m<sup>2</sup>
- · - · - 120 kg/m<sup>2</sup>

## Módena2 / dimensiones de fabricación

### Ventana de abrir / oscilobatiente

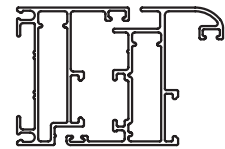
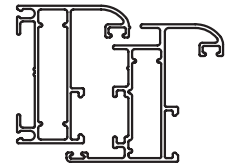
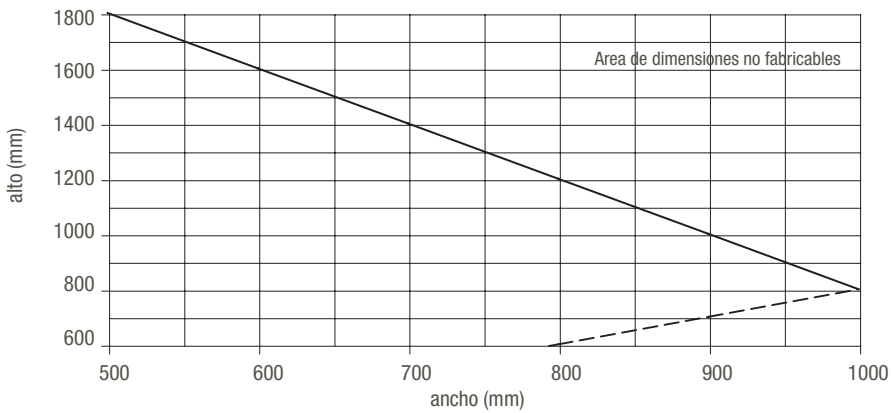

Peso máximo de hoja: 75 kg con 2 bisagras H61

Para oscilobatiente, consultar con el fabricante del accesorio tamaños mínimos y peso de la hoja  
En caso de ventana de 2 hojas, debe verificarse estructuralmente el parante central de acuerdo a la presión de viento de la zona de colocación.

### Ventana ventiluz / banderola

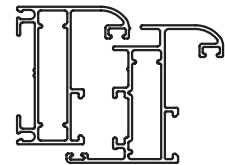
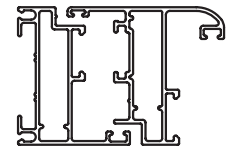
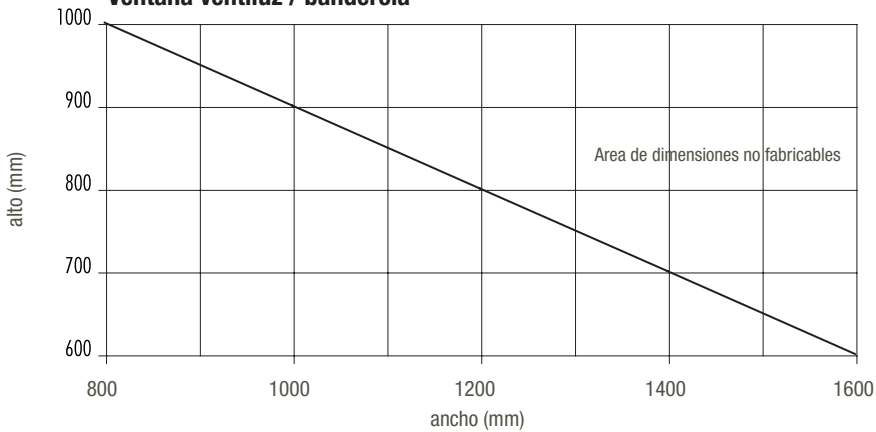

Peso máximo de hoja: 75 kg con 2 bisagras H61

### Puerta de rebatir

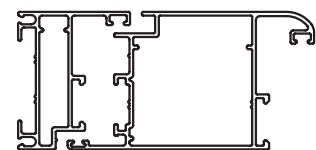
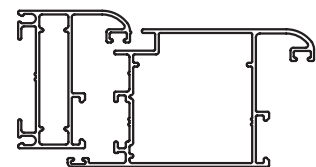
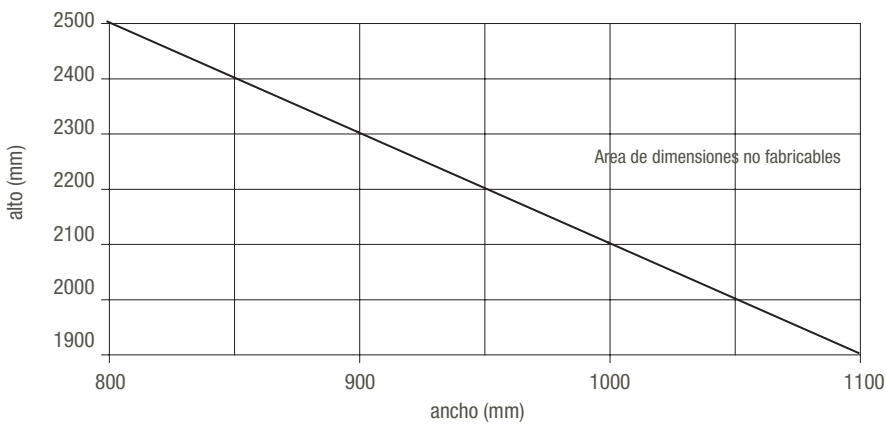

Peso máximo de hoja: 75 kg con 3 bisagras H61 o 85 kg con 3 bisagras H62

En caso de puerta de 2 hojas, debe verificarse estructuralmente el parante central de acuerdo a la presión de viento de la zona de colocación.

### **Ventana desplazable**

Con tijeras de acero inoxidable Securistyle Senator 250 o Cotswold HD 10:

Alto máximo: 750 mm

Ancho máximo: 1900 mm

Peso máximo: 50 kg

Apertura máxima: 80° (ancho mayor a 1200 mm, debe colocarse limitador de apertura)

Con tijeras de acero inoxidable Securistyle Senator 400 o Cotswold HD 16:

Alto máximo: 1100 mm

Ancho máximo: 1800 mm

Peso máximo: 60 kg

Apertura máxima: 80° (ancho mayor a 1200 mm, debe colocarse limitador de apertura)

Con tijeras de acero inoxidable Securistyle Senator 550 o Cotswold HD 22:

Alto máximo: 1300 mm

Ancho máximo: 1600 mm

Peso máximo: 70 kg

Apertura máxima: 80° (ancho mayor a 1200 mm, debe colocarse limitador de apertura)

Con tijeras de acero inoxidable Securistyle Senator 730A o Cotswold Validus:

Alto máximo: 1500 mm

Ancho máximo: 1500 mm

Peso máximo: 100 kg

Apertura máxima: 15°

### **Ventana guillotina**

Ancho máximo de hoja: 1200 mm

Alto máximo de hoja: 800 mm

### **Paño fijo**

Las dimensiones de fabricación están limitadas por el tamaño del vidrio que se va a utilizar, que de acuerdo a la presión del viento de la zona de colocación, define el espesor a utilizar.

Se recomienda verificar el perfil de contravidrio a utilizar, de acuerdo al espesor de vidrio y burletes (ver pág. 83).

Para la aplicación de contravidrios curvos, se recomienda la colocación del accesorio T96 cada 150 mm.

### **Fijaciones en general**

La recomendación para la cantidad de fijaciones mínimas a colocar son 2 por lado, que deben estar como máximo a 500 mm entre sí y a no más de 250 mm de las esquinas del marco. Para marco de menos de 500 mm de lado es aceptable colocar solo una fijación por lado.



**RDO**

Red de Distribuidores  
Oficiales

**RC©**

Red de Carpinteros  
Certificados

**ALUAR ALUMINIO ARGENTINO SAIC**

Administración: Pasteur 4600, B1644AMV, Victoria Buenos Aires

Argentina, Tel: +54 11 4725-8000

Sede Social: Marcelo T. de Alvear 590, piso 3°, C1058AAF C.A.B.A.

Argentina, Tel: +54 11 4313-7593 +54 11 4311-9026/5743

R.P.C. Nro. 2534, L° 72, F° 151, T° "A" de Est. Nac. 26/06/1970

asistenciatecnica@aluar.com.ar - www.aluar.com.ar